









KCT-04 SR
Télécommande recommandée



Modèle		KAHU-90.5	KAHU-200.5	KAHU-360.5	KAHU-560.5
Capacité de refroidissement nominale	kW	1,80 ~ 9	9 ~ 20	20 ~ 36	36 ~ 56
Poids net	kg	6,20	6,20	6,40	6,40
Type de réfrigérant				R-410A	
Protocole de communication				V6 / V8	
Diamètre du tuyau de liquide	pulg.	3/8"	3/8"	1/2"	1/2"
Diamètre du tuyau de gaz	pulg.	3/8"	3/8"	1/2"	1/2"
Dimensions (L/H/D/Pr)	mm			479 / 384 / 134	
Alimentation électrique	V/f/Hz			220-240/1/50	
Câblage d'alimentation électrique	mm ²			(2+T)x2,5	
Câblage de communication blindé	mm ²			3x0,75	

Documentation Technique	Télécharger
Manuel d'utilisation	
Certificat CE	
Contrôle manuel	
Fiches ErP	
Dimensions	  

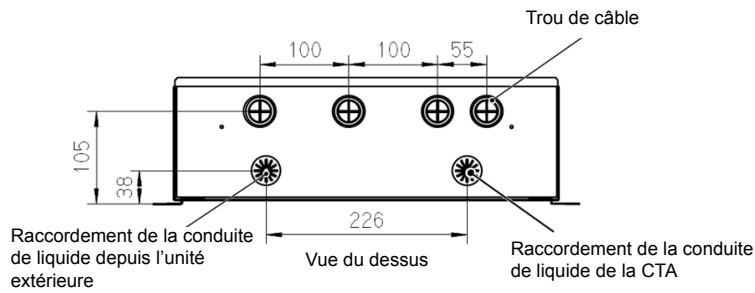

Schéma du système VRF - CTA

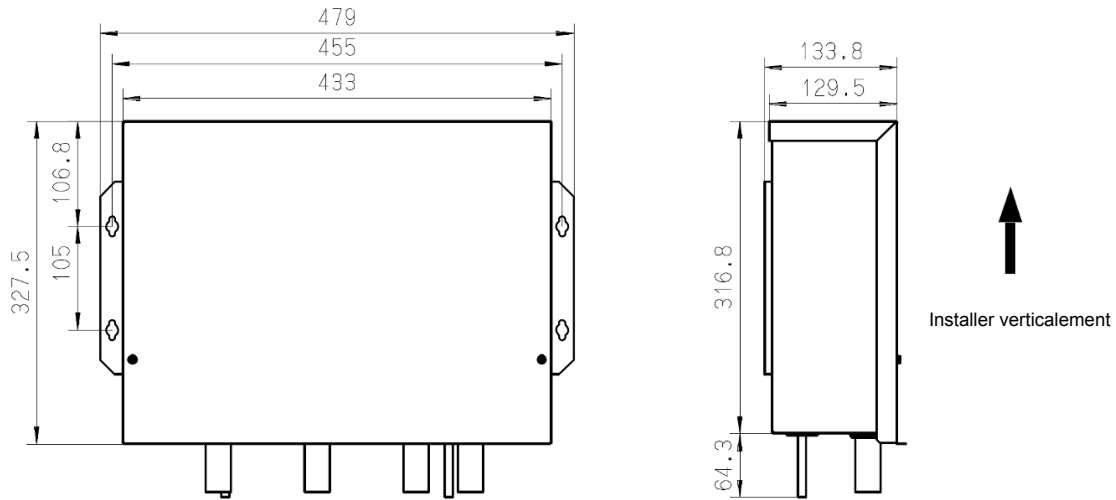