

# INSTALLATION, OPERATION AND MAINTENANCE MANUAL

## Aquantia KHP-MO HT

KHP-MO 4 DVP

KHP-MO 12 DVP

KHP-MO 12 DTP

KHP-MO 6 DVP

KHP-MO 14 DVP

KHP-MO 14 DTP

KHP-MO 8 DVP

KHP-MO 16 DVP

KHP-MO 16 DTP

KHP-MO 10 DVP



Original instructions.

All the pictures in this manual are for illustrations purpose only.



Scan the QR code to  
read the manual in  
different languages

## For ground installation and flat roof clearance – single unit

### General

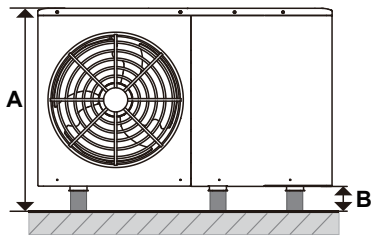

### Obstacle over the top

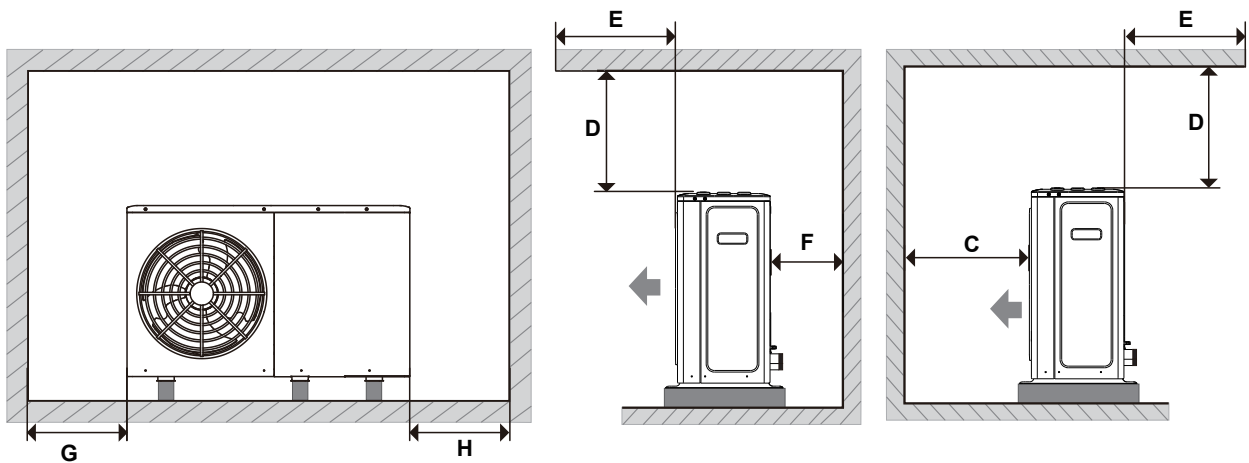

### No obstacle over the top

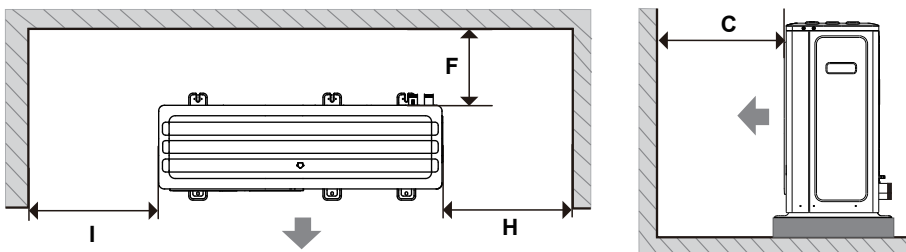

#### 4-10 kW

(mm)

<b>A</b>	Unit height + B	<b>D</b>	≥ 500	<b>G</b>	≥ 500
<b>B</b>	≥ 100 *	<b>E</b>	≤ 500	<b>H</b>	≥ 500
<b>C</b>	≥ 1 000	<b>F</b>	≥ 300	<b>I</b>	≥ 500

#### 12-16 kW

<b>A</b>	Unit height + B	<b>D</b>	≥ 500	<b>G</b>	≥ 500
<b>B</b>	≥ 100 *	<b>E</b>	≤ 500	<b>H</b>	≥ 500
<b>C</b>	≥ 1 500	<b>F</b>	≥ 300	<b>I</b>	≥ 500

\* In case of cold weather, take into account of snow on the ground. For more information, refer to 5.5 In Cold Climates.

## Clearance between units for cascade application installation

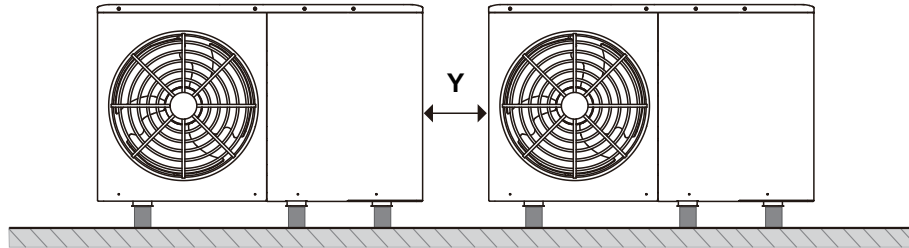
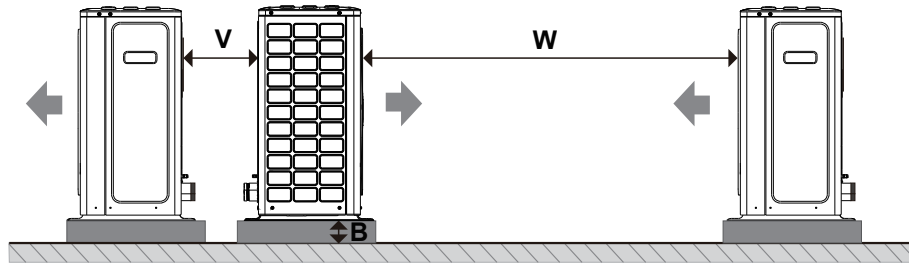

**4-10 kW**

**(mm)**

<b>V</b>	≥ 600	<b>W</b>	≥ 2 500	<b>Y</b>	≥ 500
----------	-------	----------	---------	----------	-------

**12-16 kW**

<b>V</b>	≥ 600	<b>W</b>	≥ 3 000	<b>Y</b>	≥ 500
----------	-------	----------	---------	----------	-------

For the clearance in other directions, refer to the preceding diagrams.

### **⚠ WARNING**

Read the safety precautions before installation.

# CONTENTS

<b>1 SAFETY PRECAUTIONS</b>	01
<b>2 GENERAL INTRODUCTION</b>	08
2.1 Documentation	08
2.2 Validity of the instructions	08
2.3 Unpacking	09
2.4 Accessories of the unit	09
2.5 Transportation	10
2.6 Parts to be removed	10
2.7 About the unit	11
<b>3 SYSTEM DESIGN</b>	17
3.1 Capacity and load curve	17
3.2 DHW tank (supplied by the user)	17
3.3 Room thermostat (supplied by the user)	17
3.4 Solar kit for dhw tank (supplied by the user)	17
3.5 Balance tank (supplied by the user)	17
3.6 Additional expansion vessel and water volume	18
3.7 Circulation pump	19
3.8 Thermistor	20
3.9 Typical applications	20
<b>4 SAFETY ZONE</b>	28
<b>5 UNIT INSTALLATION</b>	28
5.1 General rules	28
5.2 Installation site	29
5.3 Foundation and unit installation	29
5.4 Drainage	30
5.5 In cold climates	31
5.6 Exposure to strong sunlight	31
<b>6 HYDRAULIC INSTALLATION</b>	32
6.1 Preparations for installation	32
6.2 Water loop connection	32
6.3 Water	34
6.4 Filling water loop with water	34
6.5 Filling domestic hot water tank with water	35
6.6 Water pipe insulation	35
6.7 Freeze protection	35
6.8 Check of water loop	37
<b>7 ELECTRICAL INSTALLATION</b>	37
7.1 Opening the electrical box cover	37
7.2 Precautions for electrical wiring	37
7.3 Overview of electrical wiring	39
7.4 Electrical wiring guidelines	40
7.5 Connection with power supply	42
7.6 Connection of other components	45
7.7 Cascade function	52
7.8 Connection for other optional components	53
<b>8 INSTALLATION OF WIRED CONTROLLER</b>	54
8.1 Materials for installation	54
8.2 Dimensions	54

8.3 Wiring .....	54
8.4 Mounting .....	55
<b>9 COMPLETION OF INSTALLATION .....</b>	<b>57</b>
<b>10 CONFIGURATION .....</b>	<b>57</b>
10.1 Check before configuration .....	57
10.2 Configuration .....	58
10.3 Operation settings .....	62
<b>11 COMMISSIONING .....</b>	<b>65</b>
11.1 Test run for the actuator .....	65
11.2 Air purge .....	66
11.3 Test run .....	66
11.4 Check of the minimum flow rate .....	67
<b>12 HAND-OVER TO THE USER .....</b>	<b>67</b>
12.1 Energy saving tips .....	67
12.2 Additional operation reference .....	67
<b>13 TROUBLESHOOTING .....</b>	<b>71</b>
13.1 General guidelines .....	71
13.2 Typical abnormalities .....	71
13.3 Error codes .....	72
<b>14 MAINTENANCE .....</b>	<b>73</b>
14.1 Safety precautions for maintenance .....	73
14.2 Maintenance checklist .....	73
<b>15 SERVICE INFORMATION .....</b>	<b>74</b>
15.1 Label for refrigerant presence .....	74
15.2 Leak detection methods .....	74
15.3 Check of refrigeration equipment .....	74
15.4 Check of electrical devices .....	74
15.5 Repair of sealed components .....	74
15.6 Repair of intrinsically safe components .....	74
15.7 Transportation and marking .....	74
<b>16 DISPOSAL .....</b>	<b>74</b>
16.1 Refrigerant removal, evacuation, charge, recovery, and unit decommissioning .....	74
<b>17 TECHNICAL DATA .....</b>	<b>76</b>
17.1 General .....	76
17.2 Electrical specifications .....	77
17.3 Piping diagram .....	77
<b>ANNEX .....</b>	<b>80</b>
Annex A. Menu structure (wired controller) .....	80
Annex B. User settings parameters .....	82
Annex C. Modbus mapping table .....	86
Annex D. Available accessories .....	86
Annex E. Terms and abbreviation .....	87

---

# 1 SAFETY PRECAUTIONS

Observe the basic safety regulations before starting work and operation.

## Meaning of hazard severity panels

### DANGER

Indicates a hazard with a high level of risk which, if not avoided, will result in serious injury.

### WARNING

Indicates a hazard with a medium level of risk which, if not avoided, could result in serious injury.

### CAUTION

Indicates a hazard with a low level of risk which, if not avoided, could result in minor or moderate injury.

### NOTE

Additional information.

## Target group

### DANGER

- These instructions are exclusively intended for qualified contractors and authorized installers.
- Work on the refrigerant circuit with flammable refrigerant in safety group A3 may only be carried out by authorized heating contractors. These heating contractors must be trained in accordance with EN 378 Part 4 or IEC 60335-2-40, Section HH. The certificate of competence from an industry accredited body is required.
- Brazing/soldering work on the refrigerant circuit may only be carried out by personnel certified in accordance with ISO 13585 and AD 2000, Datasheet HP 100 R. And only contractors qualified and certified for the processes can perform brazing/soldering work. The work must fall within the range of applications purchased and be carried out in accordance with the prescribed procedures. Soldering/brazing work on accumulator connections requires certification of personnel and processes by a notified body according to the Pressure Equipment Directive (2014/68/EU).
- Work on electrical equipment may only be carried out by a qualified electrician.
- Before initial commissioning, all safety-related points must be checked by the particular certified heating contractors. The system must be commissioned by the system installer or a qualified person authorized by the installer.

## Safety precaution about the appliances using flammable refrigerant

### WARNING





- The following precautions should be complied with when installation, service, maintenance and repair, and decommissioning of appliances using flammable refrigerant.

## General

This appliance employed A3 flammable refrigerant R290.

The appliance shall be stored so as to prevent mechanical damage from occurring.

## Symbols

	WARNING	This symbol shows that this appliance used a flammable refrigerant. If the refrigerant is leaked and exposed to an external ignition source, there is a risk of fire.
	CAUTION	This symbol shows that the manual should be read carefully.
	CAUTION	This symbol shows that only a competent service personnel should be handling this equipment with reference to the technical manual.
	CAUTION	This symbol shows that information is available such as the operating manual or installation manual.

### WARNING

- Do not use means to accelerate the defrosting process or to clean, other than those recommended by the manufacturer.
- The appliance shall be stored in a room without continuously operating ignition sources (for example: open flames, an operating gas appliance or an operating electric heater).
- Do not pierce or burn.
- Be aware that refrigerants might not contain an odour.

## Installation

### ① Qualification of workers

### WARNING

- Refer to Target group described in chapter 1 SAFETY PRECAUTION.
  - Every working procedure that affects safety means shall only be carried out by competent persons.
- Examples for such working procedures are:
- breaking into the refrigerating circuit;
  - opening of sealed components;
  - opening of ventilated enclosures.

### ② General

### WARNING

- Protection devices, piping and fittings shall be protected as far as possible against adverse environmental effects, for example the danger of water collecting and freezing in relief pipes or the accumulation of dirt and debris;
- Provision shall be made for expansion and contraction of long runs of piping;
- Piping in refrigerating systems shall be so designed and installed as to minimize the likelihood of hydraulic shock damaging the system;
- Steel pipes and components shall be protected against corrosion with a rustproof coating before applying any insulation;

## Information on servicing

### ① General

#### CAUTION

Servicing shall be performed only as recommended by the manufacturer.

### ② Checks to the area

Prior to beginning work on systems containing flammable refrigerants, safety checks are necessary to ensure that the risk of ignition is minimised. For repair to the refrigerating system, DD.4.3 to DD.4.7 shall be completed prior to conducting work on the system.

### ③ Work procedure

Work shall be undertaken under a controlled procedure so as to minimise the risk of a flammable gas or vapour being present while the work is being performed.

### ④ General work area

All maintenance staff and others working in the local area shall be instructed on the nature of work being carried out. Work in confined spaces shall be avoided. The area around the workspace shall be sectioned off. Ensure that the conditions within the area have been made safe by control of flammable material.

### ⑤ Checking for presence of refrigerant

The area shall be checked with an appropriate refrigerant detector prior to and during work, to ensure the technician is aware of potentially toxic or flammable atmospheres. Ensure that the leak detection equipment being used is suitable for use with all applicable refrigerants, i.e. non-sparking, adequately sealed or intrinsically safe.

### ⑥ Presence of fire extinguisher

If any hot work is to be conducted on the refrigerating equipment or any associated parts, appropriate fire extinguishing equipment shall be available to hand. Have a dry powder or CO<sub>2</sub> fire extinguisher adjacent to the charging area.

### ⑦ No ignition sources

No person carrying out work in relation to a refrigerating system which involves exposing any pipe work shall use any sources of ignition in such a manner that it can lead to the risk of fire or explosion. All possible ignition sources, including cigarette smoking, should be kept sufficiently far away from the site of installation, repairing, removing and disposal, during which refrigerant can possibly be released to the surrounding space. Prior to work taking place, the area around the equipment is to be surveyed to make sure that there are no flammable hazards or ignition risks. "No Smoking" signs shall be displayed.

### ⑧ Ventilated area

Ensure that the area is in the open or that it is adequately ventilated before breaking into the system or conducting any hot work. A degree of ventilation shall continue during the period that the work is carried out. The ventilation should safely disperse any released refrigerant and preferably expel it externally into the atmosphere.

### ⑨ Checks to the refrigerating equipment

Where electrical components are being changed, they shall be fit for the purpose and to the correct specification. At all times the manufacturer's maintenance and service guidelines shall be followed. If in doubt, consult the manufacturer's technical department for assistance.

The following checks shall be applied to installations using flammable refrigerants:

- the refrigerant charge is in accordance with the room size within which the refrigerant containing parts are installed;
- the ventilation machinery and outlets are operating adequately and are not obstructed;
- if an indirect refrigerating circuit is being used, the secondary circuit shall be checked for the presence of refrigerant;

– marking to the equipment continues to be visible and legible. Markings and signs that are illegible shall be corrected;

– refrigerating pipe or components are installed in a position where they are unlikely to be exposed to any substance which can corrode refrigerant containing components, unless the components are constructed of materials which are inherently resistant to being corroded or are suitably protected against being so corroded.

### ⑩ Checks to electrical devices

Repair and maintenance to electrical components shall include initial safety checks and component inspection procedures. If a fault exists that could compromise safety, then no electrical supply shall be connected to the circuit until it is satisfactorily dealt with. If the fault cannot be corrected immediately but it is necessary to continue operation, an adequate

temporary solution shall be used. This shall be reported to the owner of the equipment so all parties are advised. Initial safety checks shall include:

- that capacitors are discharged: this shall be done in a safe manner to avoid possibility of sparking;
- that no live electrical components and wiring are exposed while charging, recovering or purging the system;
- that there is continuity of earth bonding.

### Sealed electrical components

#### WARNING

Sealed electrical components shall not be repaired.

### Cabling

Check that cabling will not be subject to wear, corrosion, excessive pressure, vibration, sharp edges or any other adverse environmental effects. The check shall also take into account the effects of aging or continual vibration from sources such as compressors or fans.

### Detection of flammable refrigerants

Under no circumstances shall potential sources of ignition be used in the searching for or detection of refrigerant leaks. A halide torch (or any other detector using a naked flame) shall not be used.

The following leak detection methods are deemed acceptable for all refrigerant systems.

Electronic leak detectors may be used to detect refrigerant leaks but, in the case of flammable refrigerants, the sensitivity can be inadequate, or can need re-calibration. (Detection equipment shall be calibrated in a refrigerant-free area.) Ensure that the detector is not a potential source of ignition and is suitable for the refrigerant used. Leak detection equipment shall be set at a percentage of the LFL of the refrigerant and shall be calibrated to the refrigerant employed, and the appropriate percentage of gas (25 % maximum) is confirmed.

Leak detection fluids are also suitable for use with most refrigerants but the use of detergents containing chlorine shall be avoided as the chlorine can react with the refrigerant and corrode the copper pipe-work.

NOTE Examples of leak detection methods are

- bubble method,
- fluorescent agent method.

If a leak is suspected, all naked flames shall be removed/extinguished.

If a leakage of refrigerant is found which requires brazing, all of the refrigerant shall be recovered from the system, or isolated (by means of shut-off valves) in a part of the system remote from the leak. Removal of refrigerant shall be according to Clause 8.

#### CAUTION

Oxygen free nitrogen (OFN) shall then be purged through the system both before and during the brazing process.

## Refrigerant removal and circuit evacuation

When breaking into the refrigerant circuit to make repairs – or for any other purpose – conventional procedures shall be used. However, for flammable refrigerants it is important that best practice is followed since flammability is a consideration. The following procedure shall be adhered to:

- safely remove refrigerant following local and national regulations;
- evacuate;
- purge the circuit with inert gas (optional for A2L);
- evacuate (optional for A2L);
- continuously flush with inert gas when using flame to open circuit;
- open the circuit.

The refrigerant charge shall be recovered into the correct recovery cylinders.

### CAUTION

An inert gas, specifically, is dry oxygen free nitrogen (OFN). The system shall be “flushed” with OFN to render the unit safe. This process may need to be repeated several times.

Compressed air or oxygen shall not be used for purging refrigerant systems.

Purging of the refrigerant circuit shall be achieved by breaking the vacuum in the system with inert gas and continuing to fill until the working pressure is achieved, then venting to atmosphere, and finally pulling down to a vacuum. This process shall be repeated until no refrigerant is within the system. The system shall be vented down to atmospheric pressure to enable work to take place.

### CAUTION

This operation is absolutely vital if brazing operations on the pipework are to take place.

Ensure that the outlet of the vacuum pump is not close to any potential ignition sources and that ventilation is available.

## Charging procedures

In addition to conventional charging procedures, the following requirements shall be followed.

- Ensure that contamination of different refrigerants does not occur when using charging equipment. Hoses or lines shall be as short as possible to minimise the amount of refrigerant contained in them.
- Cylinders shall be kept in an appropriate position according to the instructions.
- Ensure that the refrigerating system is earthed prior to charging the system with refrigerant.
- Label the system when charging is complete (if not already labelled).
- Extreme care shall be taken not to overfill the refrigerating system.

Prior to recharging the system, it shall be pressure-tested with the appropriate purging gas. The system shall be leak-tested on completion of charging but prior to commissioning. A follow up leak test shall be carried out prior to leaving the site.

## Decommissioning

Before carrying out this procedure, it is essential that the technician is completely familiar with the equipment and all its detail. It is recommended good practice that all refrigerants are recovered safely. Prior to the task being carried out, an oil and refrigerant sample shall be taken in case analysis is required prior to re-use of recovered refrigerant. It is essential that electrical power is available before the task is commenced.

- 1) Become familiar with the equipment and its operation.
- 2) Isolate system electrically.
- 3) Before attempting the procedure, ensure that:
  - a) mechanical handling equipment is available, if required, for handling refrigerant cylinders;
  - b) all personal protective equipment is available and being used correctly;
  - c) the recovery process is supervised at all times by a competent person;
  - d) recovery equipment and cylinders conform to the appropriate standards.
- 4) Pump down refrigerant system, if possible.
- 5) If a vacuum is not possible, make a manifold so that refrigerant can be removed from various parts of the system.
- 6) Make sure that the cylinder is situated on the scales before recovery takes place.
- 7) Start the recovery machine and operate in accordance with instructions.
- 8) Do not overfill cylinders (no more than 80 % volume liquid charge).
- 9) Do not exceed the maximum working pressure of the cylinder, even temporarily.
- 10) When the cylinders have been filled correctly and the process completed, make sure that the cylinders and the equipment are removed from site promptly and all isolation valves on the equipment are closed off.
- 11) Recovered refrigerant shall not be charged into another refrigerating system unless it has been cleaned and checked.

## Labelling

Equipment shall be labelled stating that it has been de-commissioned and emptied of refrigerant. The label shall be dated and signed. For appliances containing flammable refrigerants, ensure that there are labels on the equipment stating the equipment contains flammable refrigerant.

## Recovery

When removing refrigerant from a system, either for servicing or decommissioning, it is required to follow good practice so that all refrigerants are removed safely. When transferring refrigerant into cylinders, ensure that only appropriate refrigerant recovery cylinders are employed. Ensure that the correct number of cylinders for holding the total system charge is available. All cylinders to be used are designated for the recovered refrigerant and labelled for that refrigerant (i.e. special cylinders for the recovery of refrigerant). Cylinders shall be complete with pressure-relief valve and associated shut-off valves in good working order. Empty recovery cylinders are evacuated and, if possible, cooled before recovery occurs.

The recovery equipment shall be in good working order with a set of instructions concerning the equipment that is at hand and shall be suitable for the recovery of the flammable refrigerant. Consult manufacturer if in doubt. In addition, a set of calibrated weighing scales shall be available and in good working order. Hoses shall be complete with leak-free disconnect couplings and in good condition.

The recovered refrigerant shall be processed according to local legislation in the correct recovery cylinder, and the relevant waste transfer note arranged. Do not mix refrigerants in recovery units and especially not in cylinders.

If compressors or compressor oils are to be removed, ensure that they have been evacuated to an acceptable level to make certain that flammable refrigerant does not remain within the lubricant. The compressor body shall not be heated by an open flame or other ignition sources to accelerate this process. Draining of oil from a system shall be carried out safely.



## Intended use

There is a risk of injury to the user or others, or of damage to the product and other property in the event of improper or unintended use.

The product is the outdoor unit of an air-to-water heat pump with monoblock design.

The product uses the outdoor air as a heat source and can be used to heat a residential building and generate domestic hot water.

The air that escapes from the product must be able to flow out freely, and must not be used for any other purposes.

The product is only intended for outdoor installation.

The product is intended exclusively for domestic use, which means that the following places are not appropriate for installation:

- Where there is mist of mineral oil or oil spray or vapors. Plastic parts may deteriorate, and cause joint loose and leakage of water.
- Where corrosive gases (such as sulfurous acid gas) are produced, or corrosion of copper pipes or soldered parts may cause leakage of refrigerant.
- Where there is machinery which emits massive electromagnetic waves. Enormous electromagnetic waves can disturb the control of the system and cause equipment malfunction.
- Where flammable gases may leak, carbon fiber or ignitable dust is suspended in the air or volatile flammables such as paint thinner or gasoline are handled. These types of gases might cause a fire.
- Where the air contains high levels of salt such as a location near the ocean.
- Where voltage fluctuates a lot, such as a location in a factory.
- In vehicles or vessels.
- Where acidic or alkaline vapors are present.

Intended use includes the following:

- Observance of the operating instructions included for the product and any other installation components.
- Compliance with all inspection and maintenance conditions listed in the instructions.
- Installing and setting up the product in accordance with the product and system approval.
- Installation, commissioning, inspection, maintenance and troubleshooting by qualified contractors and authorized installers.

Intended use also covers installation in accordance with the IP code.

This appliance can be used by children aged from 8 years and above and persons with reduced physical, sensory or mental capabilities or lack of experience and knowledge provided that they have been given supervision or instruction concerning the use of the appliance in a safe way and understand the hazards involved. Children should not play with the appliance. Cleaning and maintenance should not be made by children without supervision

Any other use that is not specified in these instructions, or use beyond that specified in this document, should be considered as improper use. Any direct commercial or industrial use is also deemed to be improper.

### CAUTION

Improper use of any kind is prohibited.

- Do not rinse the unit.
- Do not place any object or equipment on top of the unit (top plate).
- Do not climb, sit or stand on top of the unit.

## Regulations to be observed

- 1) National installation regulations.
- 2) Statutory regulations for the prevention of accidents.
- 3) Statutory regulations for environmental protection.
- 4) Statutory requirements for pressure equipment: Pressure Equipment Directive 2014/68/EU.
- 5) Codes of practice of the relevant trade associations.
- 6) Relevant country-specific safety regulations.
- 7) Applicable regulations and guidelines for operation, service, maintenance, repair and safety of cooling, air conditioning and heat pump systems containing flammable and explosive refrigerant.

## Safety instructions for working on the system

The outdoor unit contains flammable refrigerant R290 (propane C3H8). In case of a leak, the escaping refrigerant may form a flammable or explosive atmosphere in the ambient air. A safety zone is defined in the immediate vicinity of the outdoor unit, in which special rules apply when work is performed on the appliance. See section "Safety zone".

## Working in the safety zone

### DANGER

Risk of explosion: Refrigerant leak may form a flammable or explosive atmosphere in the ambient air.

Take the following measures to prevent fire and explosion in the safety zone:

- Keep ignition sources away, including naked flames, plug sockets, hot surfaces, light switches, lamps, electrical devices not free of ignition sources, mobile devices with integrated batteries (such as mobile phones and fitness watches).
- Do not use any sprays or other combustible gases in the safety zone.

### CAUTION

Permissible tools: All tools for working in the safety zone must be designed and explosion-protected in accordance with the applicable standards and regulations for refrigerant in safety groups A2L and A3, such as brushless machines (cordless disposal containers, installation aids, and screwdrivers), extraction equipment, vacuum pumps, conductive hoses, and mechanical tools of non-sparking material.

### CAUTION

The tools must also be suitable for the pressure ranges in use. Tools must be in perfect maintenance conditions.

- The electrical equipment must meet the requirements for areas at risk of explosion, zone 2.
- Do not use flammable materials such as sprays or other flammable gases.
- Before starting work, discharge static electricity by touching earthed objects, such as heating or water pipes.
- Do not remove, block or bridge safety equipment.
- Do not make any changes: Do not modify the outdoor unit, inlet/ outlet lines, electrical connections/ cables or the surroundings. Do not remove any components or seals.

## Working on the system

Switch off the power supply for the unit (including all affiliated parts) at a separate fuse or mains isolator. Check and ensure that the system is no longer live.

### ⚠ CAUTION

In addition to the control circuit there may be several power circuits.

### ⚠ DANGER

Contact with live components can result in severe injuries. Some components on PCBs remain live even after the power supply has been switched off. Prior to removing covers from the appliances, wait at least 4 minutes until the voltage has completely dropped out.

- Safeguard the system against reconnection.
- Wear suitable personal protective equipment when carrying out any work.
- Do not touch any switch or electrical parts with wet fingers. It may cause electrical shock and compromise the system.

### ⚠ DANGER

Hot surfaces and fluids can result in burns or scalding. Cold surfaces may cause frostbite.

- Prior to servicing or maintenance tasks, switch off and allow the equipment to cool down or warm up.
- Do not touch hot or cold surfaces on the appliance, fittings or pipework.

### 💡 NOTE

Electronic assemblies can be damaged by electrostatic discharge. Before beginning work, touch earthed objects, such as heating or water pipes, to discharge any static.

Safety work area and temporary flammability zones.

### ⚠ CAUTION

When working on systems using flammable refrigerants, the technician should consider certain locations as "temporary flammable zones". These are normally regions where at least some emission of refrigerant is anticipated to occur during the normal working procedures, such as recovery, charging and evacuation, typically where hoses may be connected or disconnected.

The technician should ensure three meters safety working area (radius of the unit) in case of any accidental release of refrigerant that forms a flammable mixture with air.

## Working on the refrigerant circuit

R290 refrigerant (propane) is an air displacing, colorless, flammable, odorless gas which forms explosive mixtures with air. Refrigerant drained must be properly disposed of by authorized contractors.

- Perform the following measures before beginning work on the refrigerant circuit:

- Check the refrigerant circuit for leaks.
- Ensure very good ventilation especially in the floor area and maintain this for the duration of the work.
- Secure the area surrounding the work area.
- Inform the following persons of the type of work to be carried out:
  - All maintenance personnel
  - All persons in the vicinity of the system.
- Inspect the area immediately around the heat pump for flammable materials and ignition sources: Remove all flammable materials and ignition sources.
- Before, during and after the work, check the surrounding area for escaping refrigerant using an explosion-proof refrigerant detector suitable for R290. This refrigerant detector must not generate any sparks and must be suitably sealed.
- A CO<sub>2</sub> or powder extinguisher must be available in the following cases:
  - Refrigerant is being drained.
  - Refrigerant is being topped up.
  - Soldering or welding work is in progress.
- Display signs prohibiting smoking.

### ⚠ DANGER

Escaping refrigerant can lead to fires and explosions that result in very serious injuries.

- Do not drill or apply heat to a refrigerant circuit filled with refrigerant.
- Do not operate Schrader valves unless a fill valve or extraction equipment is attached.
- Take measures to prevent electrostatic charge.
- Do not smoke. Avoid naked flames and sparks. Never switch lights or electrical appliances on or off in environments with naked flames or sparks.
- Components that contain or contained refrigerant must be labeled, and stored in well ventilated areas in accordance with the applicable regulations and standards.

### ⚠ DANGER

Direct contact with liquid or gaseous refrigerant can cause serious damage to health such as frostbite and/or burns. There is a risk of asphyxiation if liquid or gaseous refrigerant is breathed in.

- Prevent direct contact with liquid or gaseous refrigerant.
- Wear personal protective equipment when handling liquid or gaseous refrigerant.
- Never breathe in any refrigerant vapor.

### ⚠ DANGER

Refrigerant is under pressure: mechanical loading of lines and components can cause leaks in the refrigerant circuit. Do not apply loads to the lines or components, such as supporting or placing tools.

### ⚠ DANGER

Hot or cold metallic surfaces of the refrigerant circuit may cause burns or frostbite in case of skin contact. Wear personal protective equipment to protect against burns or frostbite.

## NOTE

Hydraulic components may freeze during refrigerant removal. Drain heating water from the heat pump beforehand.

## DANGER

Damage to the refrigerant circuit can cause refrigerant to enter the hydraulic system. After completion of the work, vent the hydraulic system correctly. When doing so, ensure the area is sufficiently ventilated.

## Installation General

- Be sure to use only specified accessories and parts for installation. Failure to use specified parts may result in water leakage, electric shocks, fires, or the unit falling from its mount.
- Install the unit on a foundation that can withstand its weight. Insufficient physical strength may cause the unit to fall and possible injury.
- Perform specified installation work with full consideration of strong wind, hurricanes, or earthquakes. Improper installation may result in accidents due to equipment falling.
- Earth the unit and install a ground fault circuit interrupter in accordance with local regulations. Operating the unit without a proper ground fault circuit interrupter may cause electric shocks and fires.
- Install the power cable at least 3 feet (1 meter) away from televisions or radios to prevent interference or noise. (Depending on the radio waves, a distance of 3 feet (1 meter) may not be sufficient to eliminate the noise.)
- Any damaged power cord must be replaced by the manufacturer or its service agent or a similarly qualified person in order to avoid a hazard.
- This appliance can not be used at altitudes 2 000 m and above.

## CAUTION

For the primary water circulation loop:

1) Do not install any air vent valve in the indoor side. If the air vent valve has to be installed in the indoor side, no ignition sources exist around the air vent valve.

2) Make sure the outlet of the indoor safety valve leads to the outdoor side and no ignition sources exist around the outlet of safety valve.

For the secondary water circulation loop(e.g. DHW loop):

Follow the general rules for the installation of air vent valve and safety valve.

Two situations should be considered for outdoor installations to prevent damage to the system, releases, and undesirable consequences:

- Where the equipment is located in an area accessible by members of the public, and.
- Where the equipment is located in a restricted area, with access to authorized persons only.

## DANGER



Open flames, fires, open ignition sources and smoking are prohibited.

## DANGER



Inflammable matters are prohibited.

## Freezing protection

### CAUTION

Freezing can cause damage to the heat pump.

- Thermally insulate all the hydraulic lines.
- Antifreeze can be filled in the secondary circuit in accordance with local regulations and standards.

## Connecting cables

### DANGER

With short electrical cables, should there be leakage in the refrigerant circuit, gaseous refrigerant may reach the inside of the building. Min. length of the electrical connecting cables between the indoor and the outdoor unit: 3 m.

## Repair work

### CAUTION

Repairing components that fulfil a safety function can compromise the safe operation of the system.

- Replace faulty components only with genuine spare parts from the manufacturer.
- Do not undertake any repairs on the inverter. Replace the inverter if there is a defect.
- Repair work should not be performed in the field. Repair the unit in a specified location.

## Auxiliary components, spare and wearing parts

### CAUTION

Spare and wearing parts that have not been tested together with the system can compromise the function of the system. Installing non-authorized components and making non-approved modifications or conversions can compromise the safety and may invalidate our warranty. Only use original spare parts supplied or approved by the manufacturer for replacement.

## Safety instructions for operating the system

### What to do if refrigerant leaks

#### WARNING

To avoid potential risk from refrigerant leak, always keep 2 meters away from the unit, especially for kids, no matter the unit is in operation or not.

#### DANGER

Refrigerant leak can lead to fires and explosions that result in very serious injuries. Breathing in refrigerant may cause asphyxiation.

- Ensure very good ventilation especially in the floor area of the outdoor unit.
- Do not smoke. Avoid naked flames and sparks. Never switch lights or electrical appliances on or off in environments with naked flames or sparks.
- Evacuate any people from the dangerous zone.
- From a safe position, switch off the power supply for all system components.
- Remove ignition sources from the dangerous zone.
- The system user should know that no ignition source may be brought into the dangerous zone during the repair.
- Repair work must be carried out by an authorized contractor.
- Do not recommission the system until it is repaired.

#### CAUTION

Direct contact with liquid or gaseous refrigerant can cause serious damage to health, e.g. frostbite and/or burns. Breathing in liquid or gaseous refrigerant may cause asphyxiation.

- Prevent direct contact with liquid or gaseous refrigerant.
- Never breathe in refrigerant vapors.

### What to do if water leaks

#### DANGER

If water leaks from the appliance, an electric shock may occur. Switch off the heating system at the external isolator (e.g. fuse box, domestic distribution board).

#### DANGER

If water leaks from the appliance, scalding may occur. Never touch hot water.

### What to do if the outdoor unit ices up

#### CAUTION

A build-up of ice in the condensate pan and in the fan area of the outdoor unit can cause damage to the equipment.

- Do not use mechanical items/aids to remove ice.
- Before using electrical heating appliances, check the refrigerant circuit for leaks with a suitable measuring device. The heating appliance should not be a source of ignition, and must meet the requirements of EN 60335-2-30.
- If ice regularly builds up on the outdoor unit (e.g. in areas where frost and heavy fog occur frequently), install a fan ring heater that is suitable for refrigerant R290 and/or an electric ribbon heater in the condensate pan.

### Safety instructions for storage of the outdoor unit

The outdoor unit is charged at the factory with refrigerant R290 (propane).

#### DANGER

Refrigerant leak can lead to fires and explosions that result in very serious injuries. Breathing in refrigerant may cause asphyxiation. Store the outdoor unit in the following conditions:

- An explosion prevention plan must be in place for storage.
- Ensure the storage location is well ventilated.
- Keep away from ignition sources (avoid exposure to heat and smoking).
- Temperature range for storage:  $-25^{\circ}\text{C}$  to  $70^{\circ}\text{C}$
- Only store the outdoor unit in its original protective packaging from the factory.
- Protect the outdoor unit against damage.
- The maximum number of outdoor units that may be stored in one place is determined according to local conditions.

#### CAUTION

A fire with R290 should only be fought with  $\text{CO}_2$  or dry powder extinguishers.

## Disposal

This equipment uses flammable refrigerants. The disposal of the equipment must comply with national regulations.

Do not dispose this product as unsorted municipal waste. Collection of such waste separately for special treatment is necessary.

- Do not dispose of electrical appliances as unsorted municipal waste, and use separate collection facilities.
- Contact your local government for information regarding the collection systems available.

If electrical appliances are disposed of in landfills or dumps, hazardous substances can leak into the groundwater and get into the food chain, damaging your health and well-being.



**WARNING: Risk of fire**

## 2 GENERAL INTRODUCTION

### 2.1 Documentation

- Always observe all the operating and installation instructions included with the system components.
- Hand these instructions and all other applicable documents to the end user.
- Scan the QR code on the right for other languages.

This document is part of a documentation set. The complete set consists of:

Document	Content	Format
Installation Manual	Brief installation instructions	Paper (in the box next to the outdoor unit)
Installation, Operation and Maintenance Manual (this manual)	Preparation for the installation, good practices... (more information contained, for installers and advanced users only)	Digital files. Scan the QR code on the right.
Operation Manual (wired controller)	Quick guide for basic usage	Paper (in the box next to the outdoor unit)
Technical Data Manual	Performance data and ERP information	Paper (in the box next to the outdoor unit)



Scan the QR code to read the manual in different languages

#### Online Tools (APP and websites)

Refer to the OPERATION MANUAL for more information

For the terms and abbreviation, see Annex E.

### 2.2 Validity of the instructions

These instructions apply only to:

Unit	1-phase							3-phase		
	4	6	8	10	12	14	16	12	14	16
Net weight (kg)	90 (95 *)		117 (122 *)		135 (140 *)			137 (142 *)		
Wiring specification (mm <sup>2</sup> ) - main power supply	2.5-4	2.5-4	4-6	4-6	6-10	6-10	6-10	2.5-4	2.5-4	2.5-4
Minimum flow rate required (m <sup>3</sup> /h)	0.4	0.4	0.4	0.4	0.7	0.7	0.7	0.7	0.7	0.7
Capacity of backup heater	3 kW (1-phase)		3 kW (1-phase) or 6 kW (3-phase) or 9 kW (3-phase)							
Wiring specification (mm <sup>2</sup> ) - backup heater power supply	2.5-4	2.5-4	2.5-4	2.5-4	2.5-4	2.5-4	2.5-4	2.5-4	2.5-4	2.5-4

\* With a backup heater

The standard version does not include a backup heater, but it can be added as an optional feature for specific units. There are two types of backup heater, internal and external. Set dip switch correctly for internal and external application (refer to Wiring Diagram).

## 2.3 Unpacking

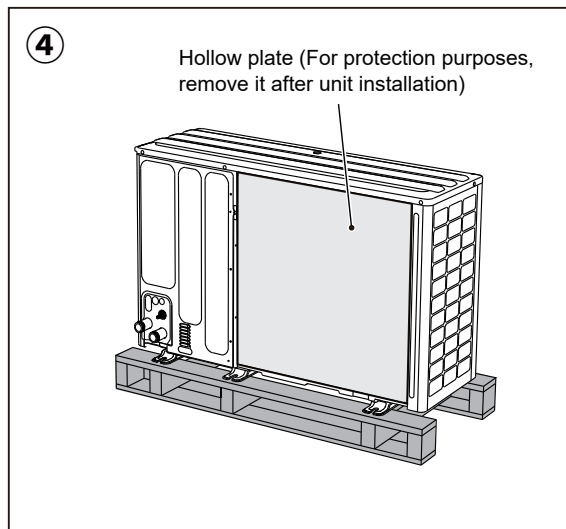
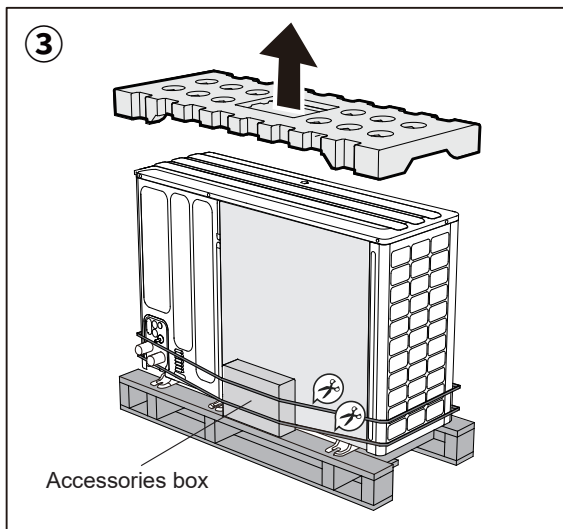
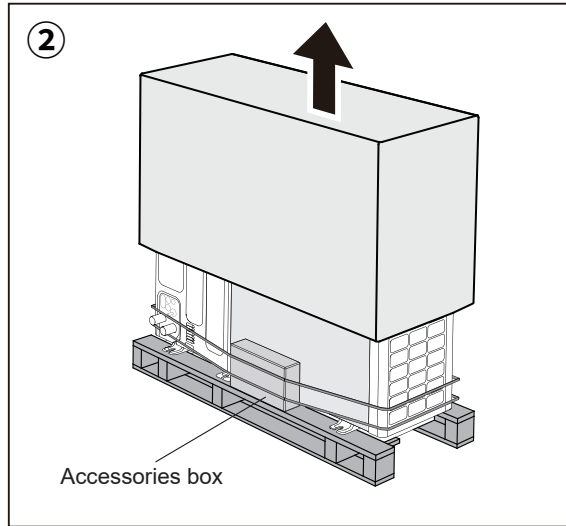
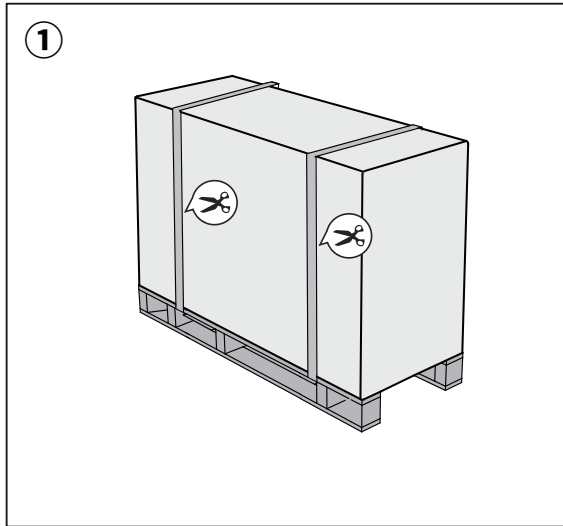

For the accessories box, see 2.4.1 Accessories supplied with the unit for more details.

### NOTE

8-16 kW units are illustrated. All units apply to the same principle.

## 2.4 Accessories of the unit

### 2.4.1 Accessories supplied with the unit

Accessories of the unit			
Name	Illustration	Quantity	Specification
Installation Manual		1	-
Technical Data Manual		1	-
Operation Manual		1	-
Y-Type Strainer		1	4-6 kW:G 1"
			8-16 kW:G 1 1/4"
Wired Controller Box		1	-

Thermistor (T5 or Tw2 or Tbt)		1	10 m
Drain Joint		1	φ32
Energy Label		1	-
Tie Wrap		4	-
Paper Edge Protector		1	A
		1	B
Network Matching Resistor		1	-
Extension Wire for T5 or Tw2 or Tbt		1	-

If the accessories box of the actual product is inconsistent with this list, Please refer to the list in the Installation Manual.

## 2.4.2 Available options

Besides the standard supplied unit, all possible options of the unit can be found in Annex E. Available accessories.

## 2.5 Transportation

### 2.5.1 Dimensions and barycenter

The illustrations below are for 8-16 kW units. The principle is the same for 4-6 kW units. A, B, and C indicate the locations of barycenter.

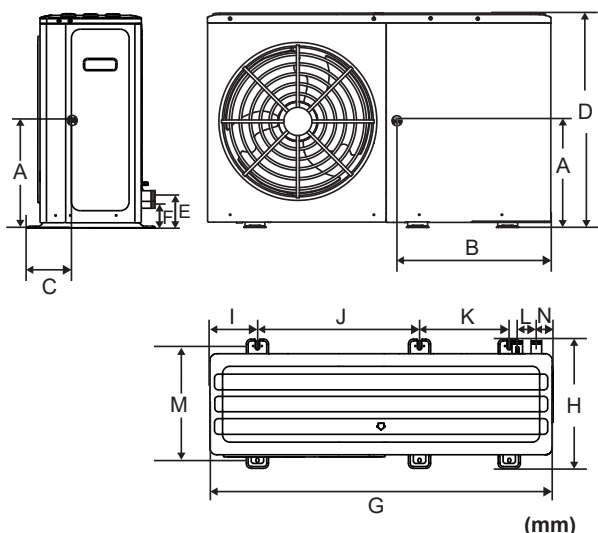

Model	A	B	C	D	E
1 phase 4/6 kW	333	528	210	717	91
1 phase 8/10 kW	360	550	234	865	129
1 phase 12/14/16 kW	415	715	200	865	129
3 phase 12/14/16 kW	415	715	200	865	129

F	G	H	I	J	K	L	M	N
91	1 299	426	121	644	379	90	375	71
100	1 385	523	192	656	363	77	456	68
100	1 385	523	192	656	363	77	456	68
100	1 385	523	192	656	363	77	456	68

### 2.5.2 Manual transportation

#### ⚠ WARNING

Risk of injury from lifting a heavy weight. Lifting weights that are too heavy may cause injury to the spine, for example.

- Note the weight of the product.
- Have four people lift the product.

1. Take into consideration the weight distribution during transportation. The product is significantly heavier on the compressor side than on the fan motor side. (see content above for the barycenter)
2. Protect the casing sections from damage. Using paper edge protector under the unit when lift the unit.
3. After transportation, remove the transport straps.
4. During transportation, do not tilt the product to an angle larger than 45°.

### 2.5.3 Lifting

Use lifting tools with transport straps or a suitable hand truck. Unit on the pallet:

Pass the transport straps through the holes on the left and right sides of the pallet properly.

No pallet under the unit:

The transport straps can be fitted into the dented position at the base frame that are made specifically for this purpose. Using paper edge protector under the unit when lifting the unit.

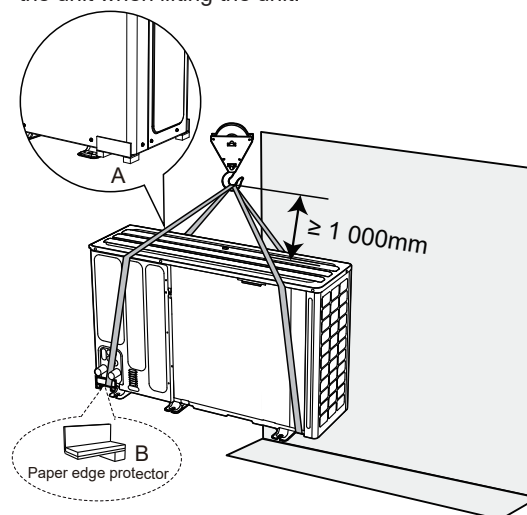

#### ⚠ CAUTION

The barycenter of the product and the hook should be kept in a straight line in the vertical direction to prevent excessive tilting.

### 2.6 Parts to be removed

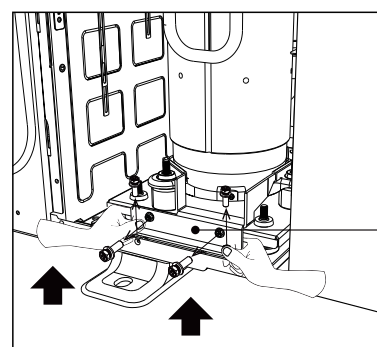
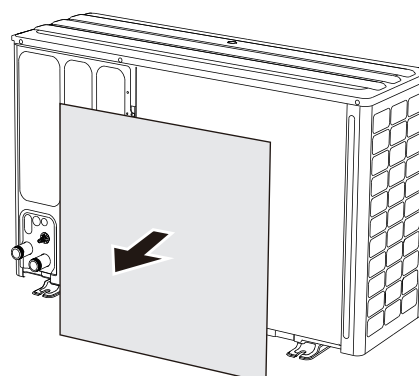

Remove the transportation support

For 12/14/16 kW

To open the unit, see 7.1 Opening the Electrical Box Cover.

#### ⚠ CAUTION

Move the parts above after unit installation.

## 2.7 About the unit

### 2.7.1 Overview

The unit applies to heating, cooling, and DHW scenarios. It can be used together with fan coil units, floor heating devices, low-temperature high-efficiency radiators, domestic hot water tanks, and solar kits.

The backup heater can increase the heating capacity at extremely low ambient temperatures. It serves as a backup heating source in case of heat pump failure or freeze protection of the water piping out side in winter.

### 2.7.2 Layout

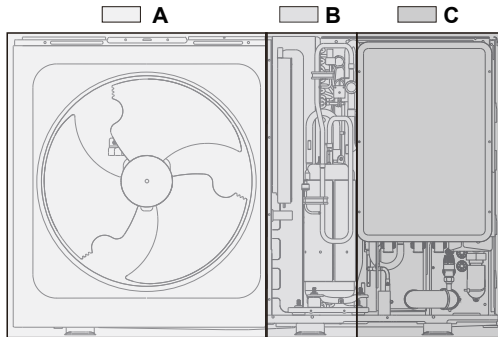

- A – Fan chamber
- B – Mechanical chamber
- C – Hydraulic module

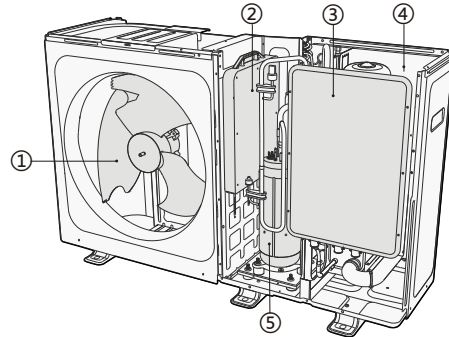

- ① Fan
- ② Inverter control box
- ③ Main control box
- ④ Hydraulic module
- ⑤ Compressor

### 2.7.3 Hydraulic module

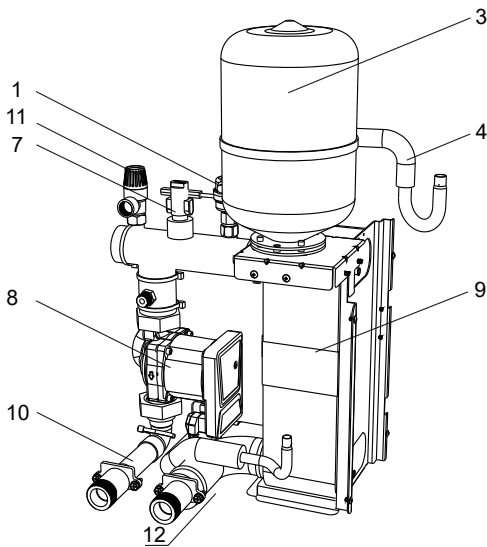

4/6 kW unit without a backup heater

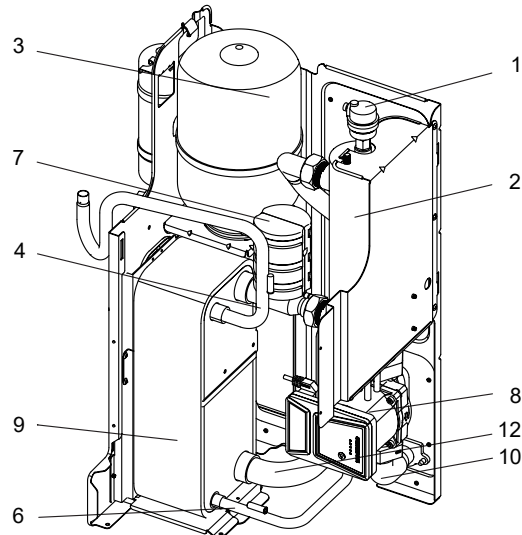

4/6 kW unit with a backup heater (optional)

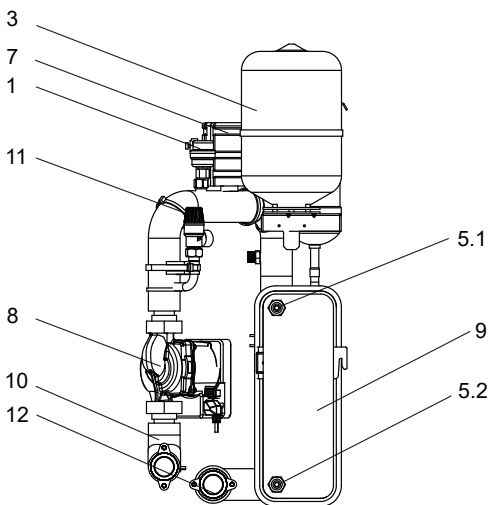

8 -16 kW unit without a backup heater

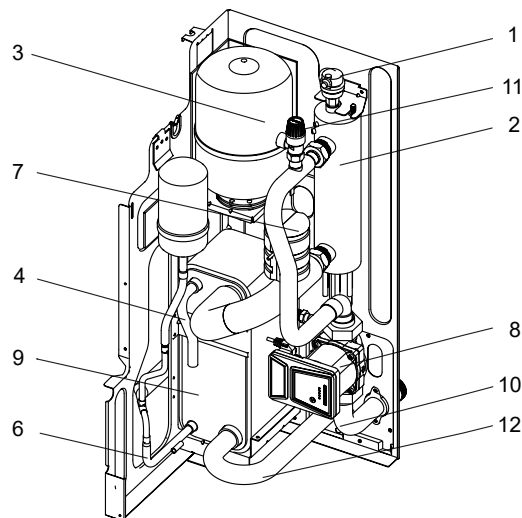

8 -16 kW unit with a backup heater (optional)



Code	Assembly Unit	Explanation
1	Automatic air purge valve	Automatically removes the remaining air from the water loop.
2	Backup heater (optional)	Provides additional heating capacities when the heating capacity of the heat pump is insufficient due to low outdoor temperature, and protects the external water pipes from freezing.
3	Expansion vessel	Balances the water system's pressure.
4	Refrigerant gas pipe	/
5	Temperature sensor	Four temperature sensors determine the water and refrigerant temperature at various points in the water loop: 5.1-TW_out, and 5.2-TW_in
6	Refrigerant liquid pipe	/
7	Flow switch	Detects the water flow rate to protect the compressor and water pump in the event of insufficient water flow.
8	Pump	Circulates water in the water loop.
9	Plate heat exchanger	Transfers heat from the refrigerant to the water.
10	Water outlet pipe	/
11	Pressure relief valve	Prevents excessive water pressure by opening when the pressure reaches 0.3 MPa(3 bar) and discharging water from the water loop.
12	Water inlet pipe	/

## 2.7.4 Control board

### Main control board

4/6 kW, 8/10 kW, 12/14/16 kW(1Ph), 12/14/16 kW(3Ph)

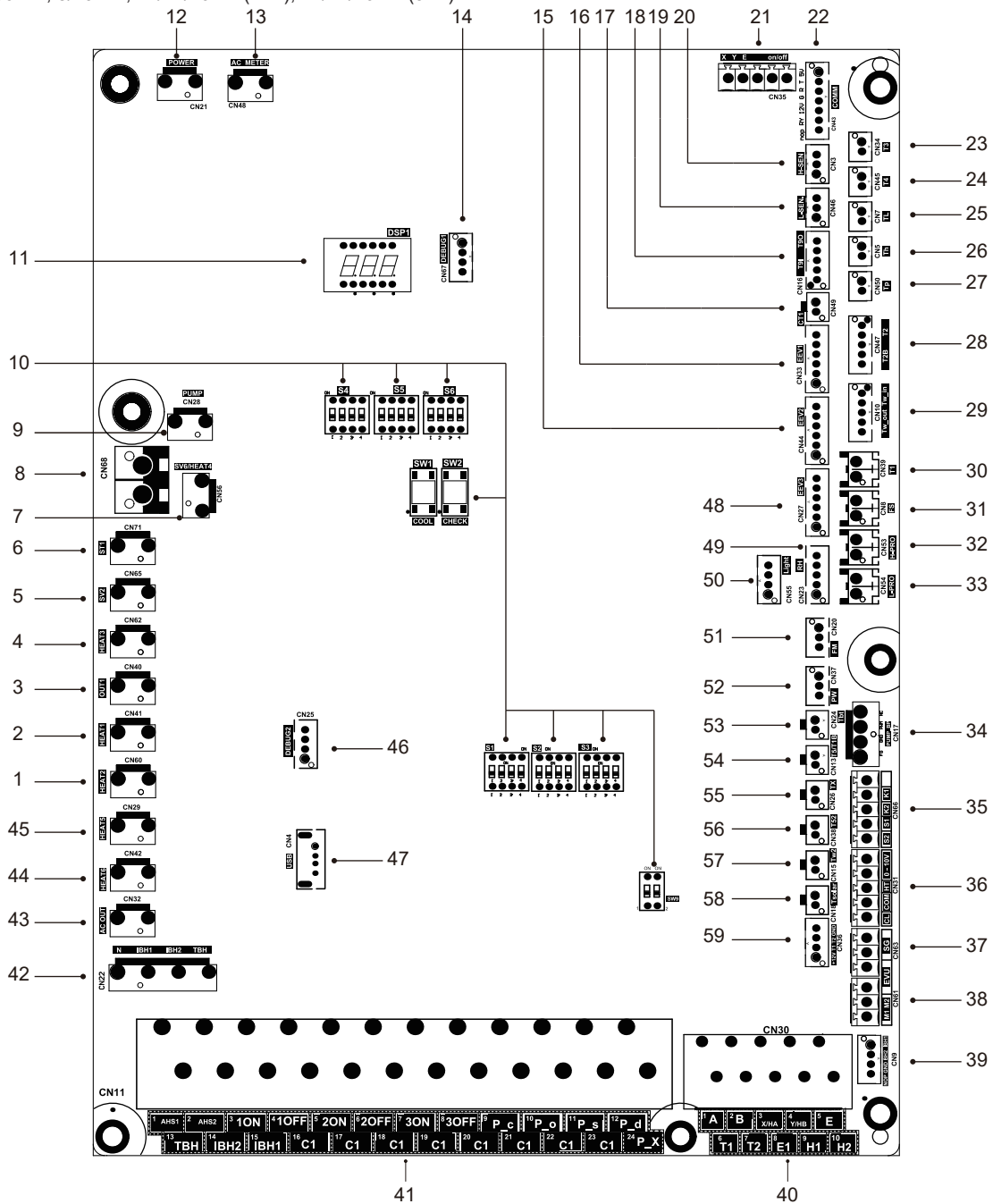

Order	Port	Stamp	Explanation		Order	Port	Stamp	Explanation	
1	CN60	HEAT2	Reserved		36	CN31	0-10V	Output port for 0-10V	0-5 V DC
2	CN41	HEAT1	Reserved	230 V AC			HT	Control port for room thermostat (heating mode)	0-5 V DC
3	CN40	OUT1	OUT1	230 V AC			COM	Power port for room thermostat	0-5 V DC
4	CN62	HEAT3	Port for crankcase heating tape	230 V AC			CL	Control port for room thermostat (cooling mode)	0-5 V DC
5	CN65	SV2	Reserved		37	CN63	SG	Port for smart grid (grid signal)	0-12 V DC
6	CN71	ST1	Port for 4-way valve	230 V AC			EVU	Port for smart grid (photovoltaic signal)	0-12 V DC
7	CN56	/	Port for the heating tape of bottom plate	230 V AC	38	CN61	M1 M2	Port for remote switch	0-12 V DC
8	CN68	/	Port for the heating tape of drainage outlet	230 V AC	39	CN9	/	Control port for internal backup heater	0-5 V DC
9	CN28	PUMP	Port for variable speed pump power input		40	CN30	1,2	Port for additional heat source	
10	/	/	Dip switch				3,4	Port for communication with the wired controller	
11	DSP1	/	Digital display				6,7	Port for thermostat transfer board	
12	CN21	POWER	Port for power supply	230 V AC			9,10	Port for machine Cascade	
13	CN48	AC METER	Reserved		41	CN11	1 2	Port for additional heat source	230 V AC
14	CN67	DEBUG1	Port for IC programming				3 4 17	Port for SV1(3-way valve)	230 V AC
15	CN44	EEV2	Port for electrical expansion valve2				5 6 18	Port for SV2(3-way valve)	230 V AC
16	CN33	EEV1	Port for electrical expansion valve1(Reserved)	0-12 V DC			7 8 19	Port for SV3(3-way valve)	230 V AC
17	CN49	CT1	Port for current transformer(Reserved)				9 20	Port for zone 2 pump	230 V AC
18	CN16	T9O/T9I	Reserved				10 21	Port for outside circulation pump	230 V AC
19	CN46	L-SEN	Port for low pressure sensor	0-5 V DC			11 22	Port for solar energy pump	230 V AC
20	CN3	H-SEN	Port for high pressure sensor	0-5 V DC			12 23	Port for DHW pump	230 V AC
21	CN35	RS485 on/off	Reserved	0-5 V DC			13 16	Control port for tank booster heater	230 V AC
22	CN43	COMM	Port for communication with Inverter module	0-5 V DC			14 16	Control port for internal backup heater 1	230 V AC
23	CN34	T3	Port for T3 temp.sensor	0-3.3 V DC			15 17	Control port for internal backup heater 2	230 V AC
24	CN45	T4	Port for T4 temp.sensor	0-3.3 V DC	42	CN22	IBH1	Control port for internal backup heater 1	230 V AC
25	CN7	TL	Port for TL temp.sensor	0-3.3 V DC			IBH2	Control port for internal backup heater 2	230 V AC
26	CN5	Th	Port for Th temp.sensor	0-3.3 V DC			TBH	Control port for tank booster heater	230 V AC
27	CN50	Tp	Port for Tp temp.sensor	0-3.3 V DC	43	CN32	AC OUT	Port for transformer power input	230 V AC
28	CN47	T2	Port for refrigerant liquid side temperature (heating mode)	0-5 V DC	44	CN42	HEAT6	Port for anti-freeze electric heating tape(internal)	230 V AC
		T2B	Port for temperature sensors of refrigerant gas side temperature (cooling mode)	0-5 V DC	45	CN29	HEAT5	Port for anti-freeze electric heating tape(internal)	230 V AC
29	CN10	TW_in	Port for temperature sensors of inlet water temperature of plate heat exchanger	0-5 V DC	46	CN25	DEBUG2	Port for IC programming	
		TW_out	Port for temperature sensors of outlet water temperature of plate heat exchanger	0-5 V DC	47	CN4	USB	Port for USB programming	
30	CN39	T1	Port for temperature sensors of final outlet water temperature	0-5 V DC	48	CN27	EEV3	Port for electrical expansion valve3(Reserved)	
31	CN8	FS	Port for flow switch	0-12 V DC	49	CN23	RH	Port for humidity sensor	
32	CN53	H-PRO	Port for high pressure switch(Reserved)		50	CN55	Light	Port for breathing light	
33	CN54	L-PRO	Port for low pressure switch(Reserved)		51	CN20	FM	Port for water flow sensor	0-5 V DC
34	CN17	PUMP_BP	Port for variable speed pump communication	0-5 V DC	52	CN37	PW	Port for water pressure sensor	0-5 V DC
35	CN66	K1,K2	Port for high pressure switch	0-5 V DC	53	CN24	Tbt	Port for temperature sensor of balance tank	0-5 V DC
		S1,S2	Port for high pressure switch	0-5 V DC	54	CN13	T5/T1B	Port for domestic hot water tank temp. sensor	0-5 V DC
					55	CN26	TX	Reserved	
					56	CN38	T52	Port for temperature sensor of balance tank 2	0-5 V DC
					57	CN15	Tw2	Port for outlet water for zone 2 temp. sensor	0-5 V DC
					58	CN18	Tsolar	Port for solar panel temp sensor	0-5 V DC
					59	CN36	/	Port for thermostat transfer board	0-12 V DC

## Inverter module

1) 4/6 kW, 8/10 kW

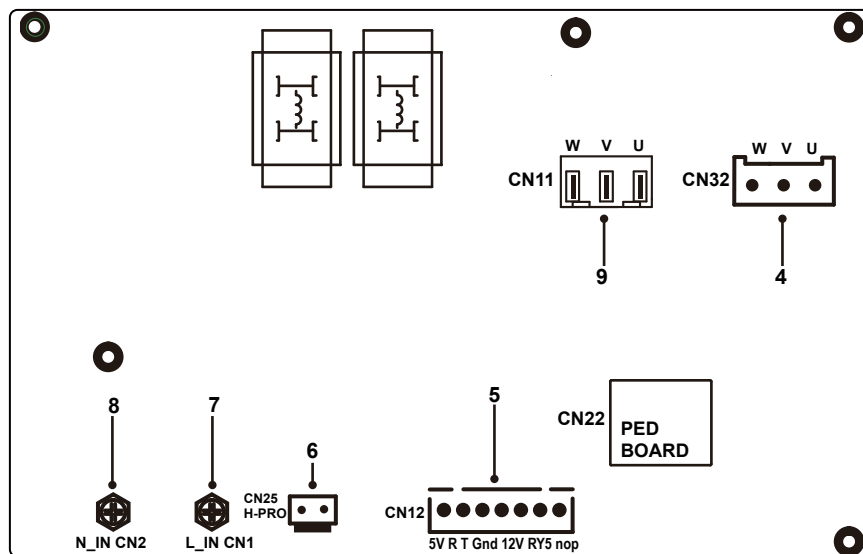

2) 12/14/16 kW (1Ph)

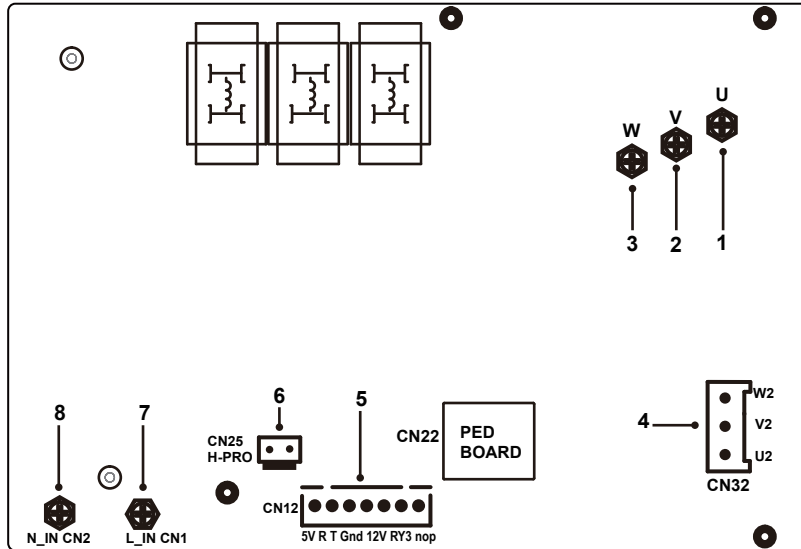

Order	Port	Stamp	Explanation	Port voltage
1	U	/	Power output U of inverter module to compressor	Above 156 V DC (varying according to frequency)
2	V	/	Power output V of inverter module to compressor	Above 156 V DC (varying according to frequency)
3	W	/	Power output W of inverter module to compressor	Above 156 V DC (varying according to frequency)
4	CN32	/	DC fan power ports	Above 156 V DC (varying according to frequency)
5	CN12	/	Port for communication with Main control board	0-5 V DC
6	CN25	H-PRO	Connect to high pressure switch	0-5 V DC
7	CN1	L_IN	Power input L of inverter module	230 V AC
8	CN2	N_IN	Power input N of inverter module	230 V AC
9	CN11	/	Power output of inverter module to compressor	Above 156 V DC (varying according to frequency)

12/14/16 kW(3Ph)

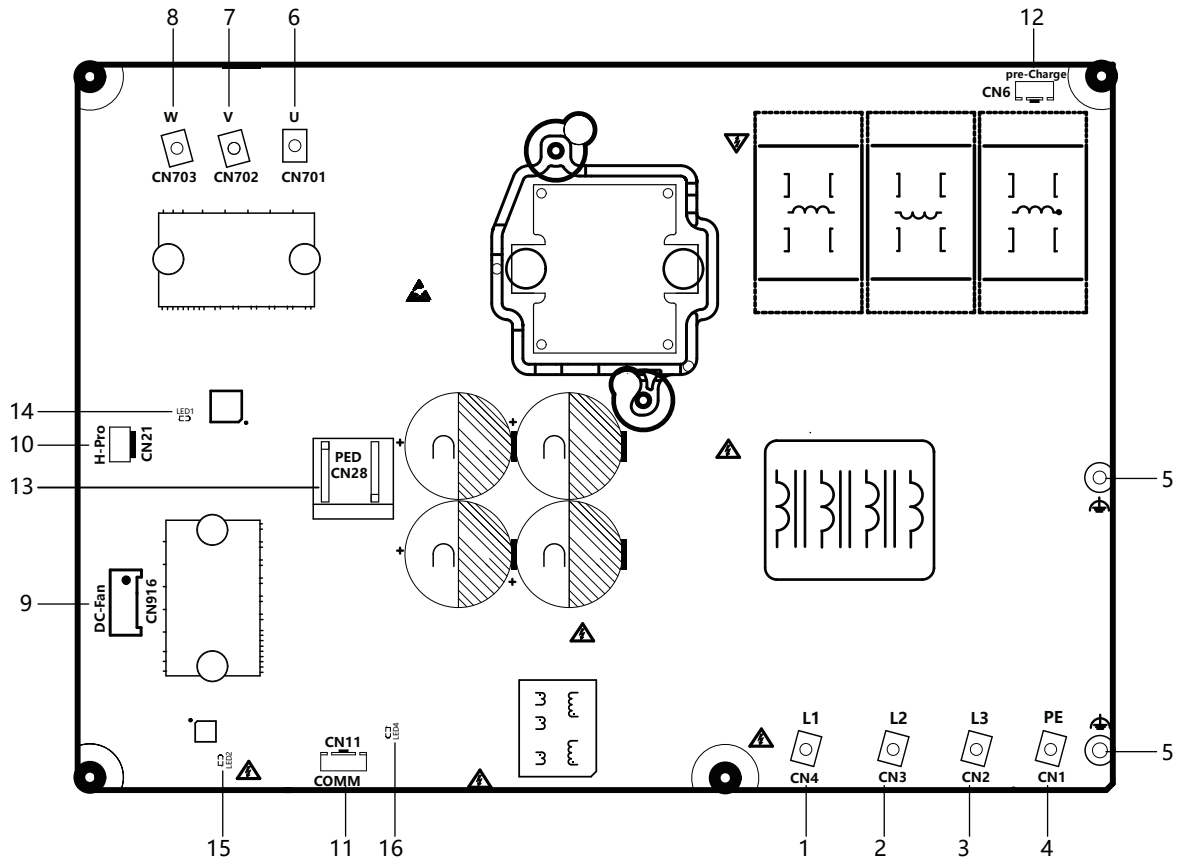

Order	Port	Stamp	Explanation	Port voltage
1	CN4	L1	Power Input port L1(CN2)	Rated phase-to-phase 380 V AC
2	CN3	L2	Power Input port L2(CN3)	Rated phase-to-phase 380 V AC
3	CN2	L3	Power Input port L3(CN4)	Rated phase-to-phase 380 V AC
4	CN1	PE	Earthing	/
5	/	/	Functional earthing	/
6	CN701	U	Compressor connection port U(CN701)	Phase-to-phase 46-460 V AC
7	CN702	V	Compressor connection port V(CN702)	Phase-to-phase 46-460 V AC
8	CN703	W	Compressor connection port W(CN703)	Phase-to-phase 46-460 V AC
9	CN916	DCFAN	Port for fan(CN916)	Phase-to-phase 46-460 V AC
10	CN21	H-Pro	Port for high pressure switch (CN21)	Close: 0 V ; Open: 6 V ;
11	CN11	COMM	Port for communication with main control board (CN11)	From left to right: 5 V、 +、 -、 GND
12	CN6	Pre-charge	Pre-charge relay (low power) control port	During working:12 V DC ;
13	CN28	PED	PED module, Safety Diagnostic Module	/
14	LED1	COMP	Compressor drive status indicator	/
15	LED2	Fan	Fan drive status indicator	/
16	LED3	Power	5V power status indicator	/

### 3)IBH control board 3-phase IBH

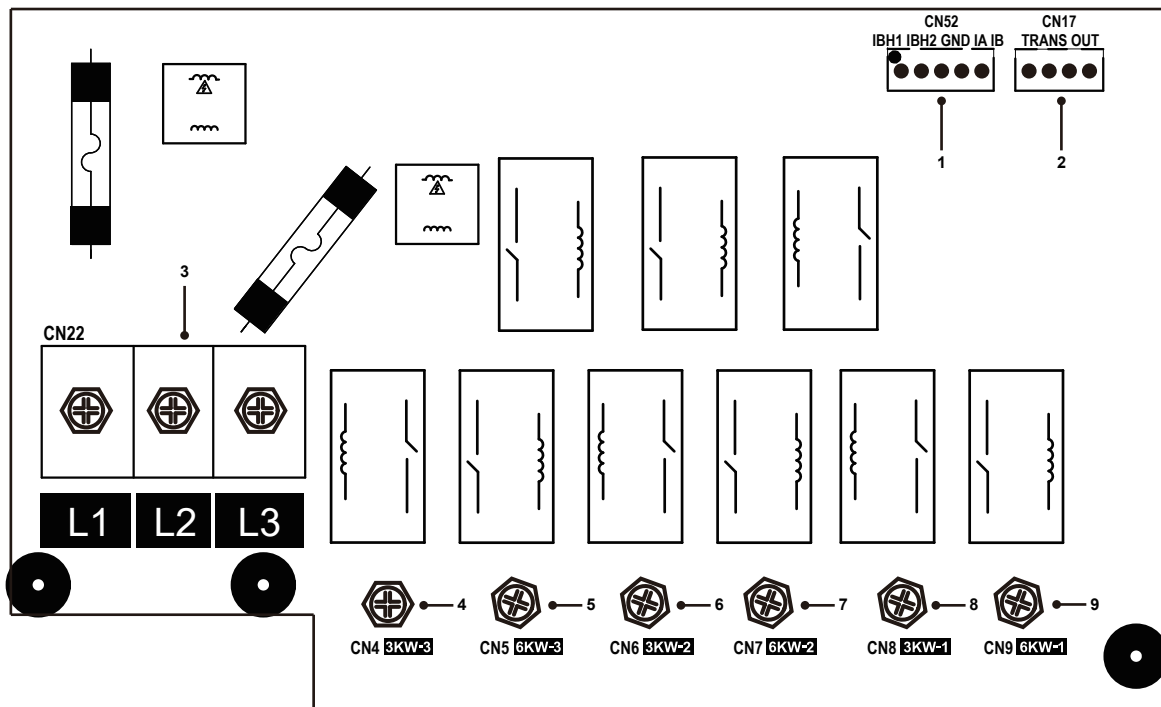

Order	Port	Code	Explanation	Port voltage
1	CN52	IBH1 IBH2 GND IA IB	IBH control and feedback signal port	0-12 V DC
2	CN17	TRANS OUT	Linear transformers output low voltages	9-13.5 V AC
3	CN22	L1 L2 L3	Power input of IBH control board	380 V AC
4	CN4	3 kW-3	Power output of one step IBH	380 V AC
5	CN5	6 kW-3	Power output of two step IBH	380 V AC
6	CN6	3 kW-2	Power output of one step IBH	380 V AC
7	CN7	6 kW-2	Power output of two step IBH	380 V AC
8	CN8	3 kW-1	Power output of one step IBH	380 V AC
9	CN9	6 kW-1	Power output of two step IBH	380 V AC

## 1-phase IBH

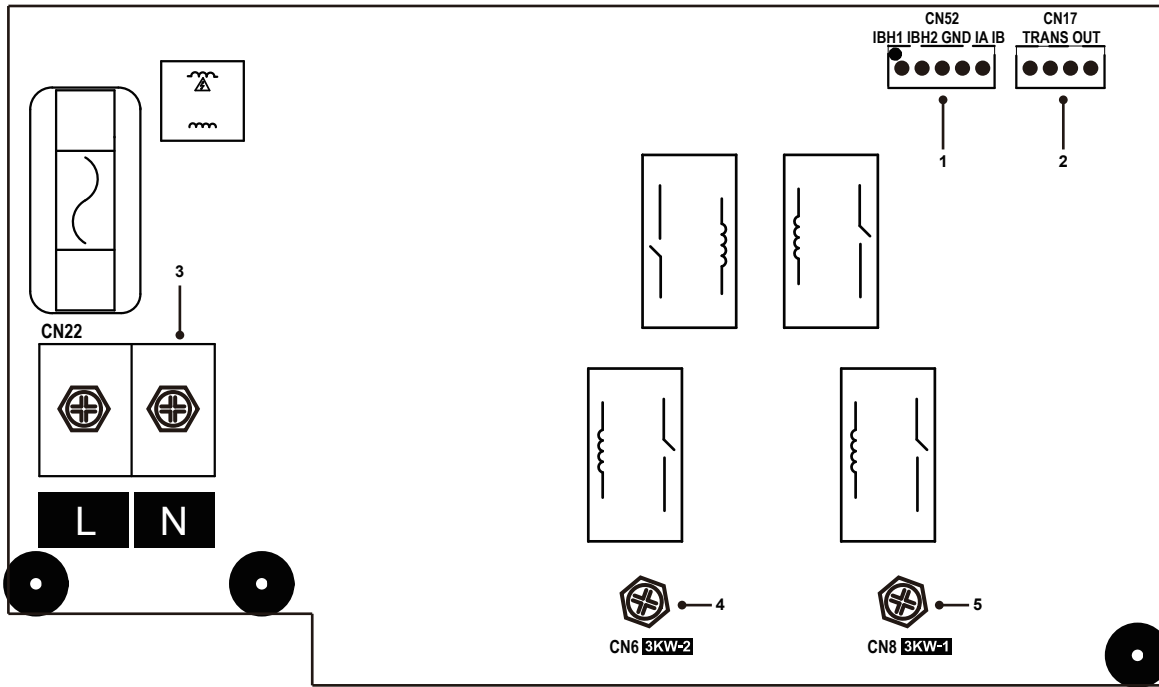

Order	Port	Code	Explanation	Port voltage
1	CN52	IBH1 IBH2 GND IA IB	IBH control and feedback signal port	0-12 V DC
2	CN17	TRANS OUT	Linear transformers output low voltages	9-13.5 V AC
3	CN22	L N	Power input of IBH control board	230 V AC
4	CN4	3 kW-2	Power output of one step IBH	230 V AC
5	CN5	3 kW-1	Power output of one step IBH	230 V AC

### 2.7.5 Operating range

In cooling mode, the product works at an outdoor temperature of -5 °C to 46 °C.

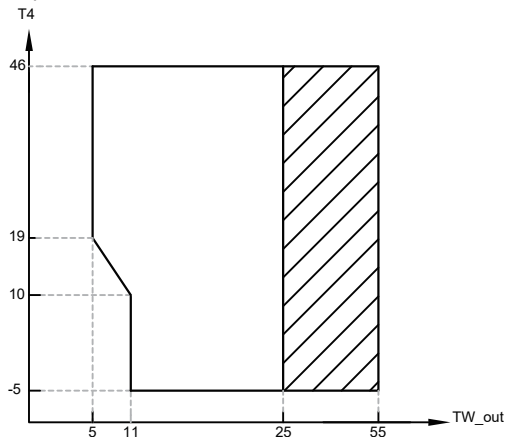

Operating range of heat pump with possible limitation and protection.

TW\_out leaving water temperature  
T4 outdoor ambient temperature

In heating mode and DHW mode, the product works at an outdoor temperature of -25 °C to 46 °C

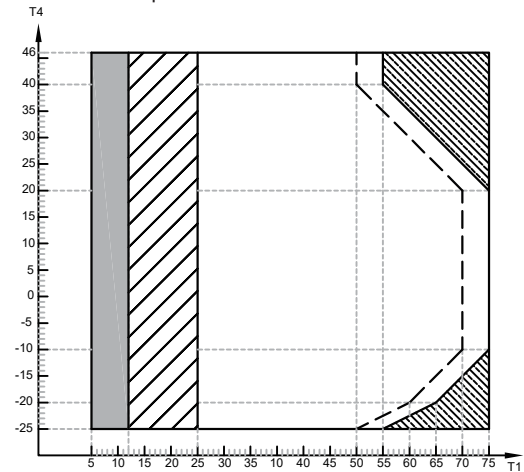

In case of invalid IBH/AHS settings, only the IBH/AHS turns on;  
 In case of invalid IBH/AHS settings, only the heat pump turns on. Limitation and protection may occur during heat pump operation. Operating range of heat pump with possible limitation and protection.  
 The heat pump remains off, and only the IBH/AHS turns on.  
 Maximum inlet water temperature line for heat pump operation.

T1 leaving water temperature  
T4 outdoor ambient temperature

In DHW mode, the product works at an outdoor temperature of -25 °C to 46 °C

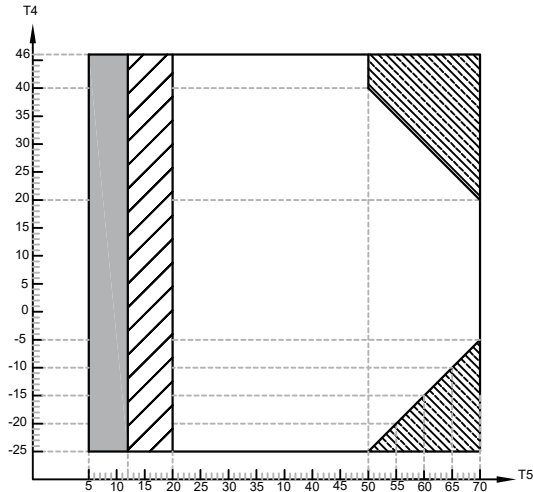

- In case of valid TBH/IBH/AHS settings, only the TBH/IBH/AHS turns on;
- In case of valid TBH/IBH/AHS settings, only the heat pump turns on. Limitation and protection may occur during heat pump operation. Operating range of heat pump with possible limitation and protection.
- The heat pump remains off, and only the TBH/IBH/AHS turns on.

T5 DHW tank temperature  
T4 outdoor ambient temperature

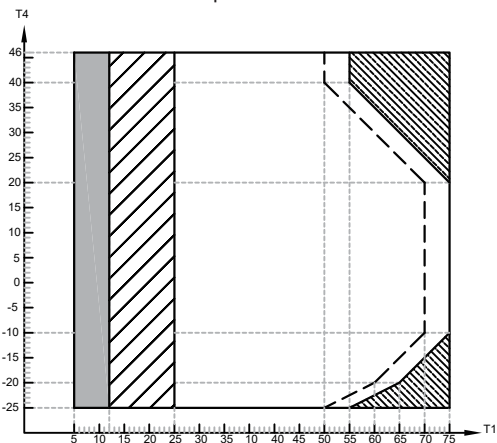

- In case of invalid IBH/AHS settings, only the IBH/AHS turns on;
- In case of invalid IBH/AHS settings, only the heat pump turns on. Limitation and protection may occur during heat pump operation. Operating range of heat pump with possible limitation and protection.
- The heat pump remains off, and only the IBH/AHS turns on.
- Maximum inlet water temperature line for heat pump operation.

T1 leaving water temperature  
T4 outdoor ambient temperature

### 3 SYSTEM DESIGN

#### 3.1 Capacity and load curve

Match the load with appropriate capacity of the unit based on the curve below.

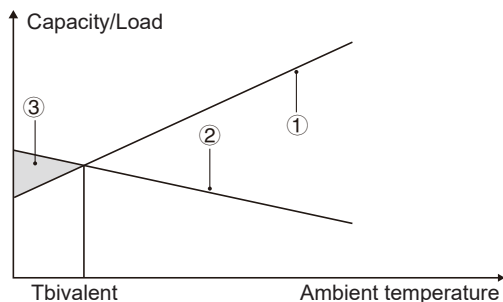

- ① Heat pump capacity
- ② Required heating capacity (site-dependent)
- ③ Additional heating capacity provided by backup heaters

For further details, consult with your supplier.

#### 3.2 DHW tank (supplied by the user)

A domestic hot water (DHW) tank (with or without a booster heater) can be connected to the unit.

The requirements for the tank vary with the unit model and the heat exchanger material.

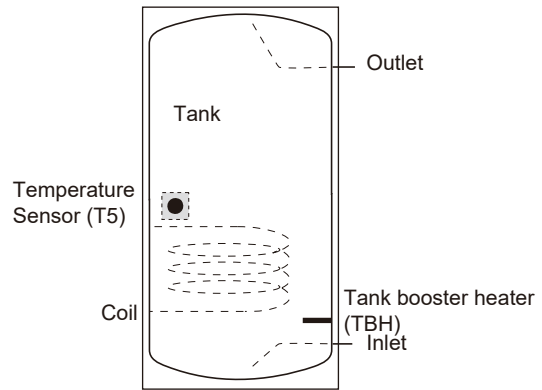

The booster heater should be installed below the temperature probe (T5).

The heat exchanger (coil) should be installed below the temperature probe.

Model		4-6 kW	8-10 kW	12-16 kW
Tank volume/L	Recommended	100~250	150~300	200~500
Heat exchange area/m <sup>2</sup> (stainless steel coil)	Minimum	1.4	1.4	1.6
Heat exchange area/m <sup>2</sup> (enamel coil)	Minimum	2.0	2.0	2.5

See 6.1.5 Requirements for third-party tanks for more information.

#### 3.3 Room thermostat (supplied by the user)

The room thermostat can be connected to the unit, and it should be kept away from heating sources.

#### 3.4 Solar kit for dhw tank (supplied by the user)

An optional solar kit can be connected to the unit.

The unit can be controlled by T<sub>solar</sub> or by the input signal. See 9.3.7 Other heat sources.

#### 3.5 Balance tank (supplied by the user)

The installation of a balance tank in the system can effectively reduce the unit startup frequency, and achieve efficient defrosting and mitigate room temperature fluctuations. The recommended balance tank size is as follows:

No.	Model	Balance tank (L)
1	4-10 kW	≥ 25
2	12-16 kW	≥ 40
3	Cascade system	≥ 40 * n

n: Quantity of outdoor units

### 3.6 Additional expansion vessel and water volume

The units are equipped with an expansion vessel of 8L(effective volume is 5 L, use effective volume for calculation) that has a default pre-pressure of 1.5 bar. When the capacity of the integrated expansion vessel is insufficient for the system due to high water volume, an additional expansion vessel (supplied by the user) is needed.

Refer to the formula below to determine the specification of the additional expansion vessel.

System with only water	System with 35 % glycol
$V_2 = \frac{4C * 0.0258 - V_1 * (3 - Pg_1)}{3 - Pg_2}$	$V_2 = \frac{4C * 0.0179 - V_1 * (3 - Pg_1)}{3 - Pg_2}$

V2: Additional expansion vessel volume, in L;

V1: Integrated expansion vessel volume, in L, 5 L;

C: System water volume, in L;

Pg2: Additional expansion vessel Pre-pressure (relative pressure), in bar.

Pg1: Integrated expansion vessel Pre-pressure (relative pressure), in bar, 1.5 bar.

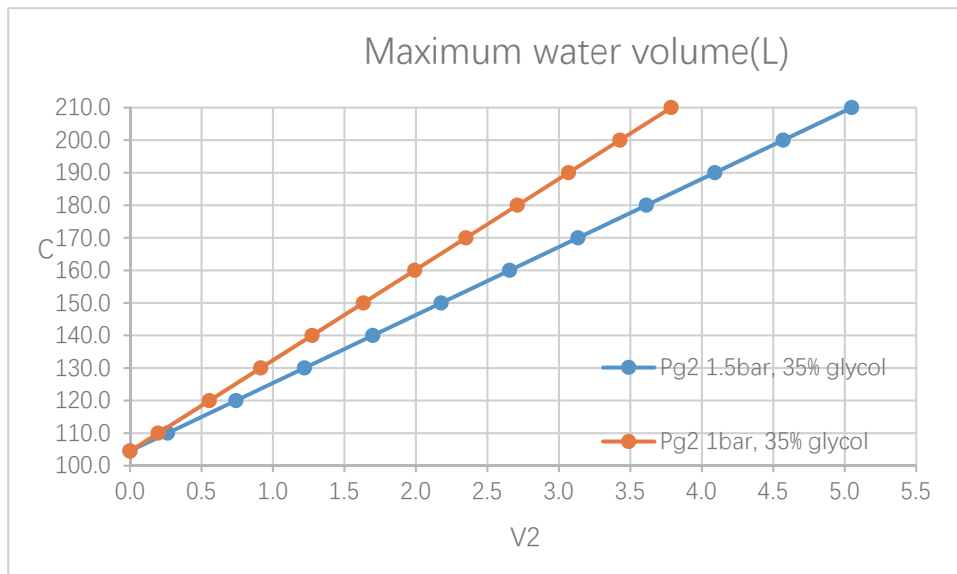
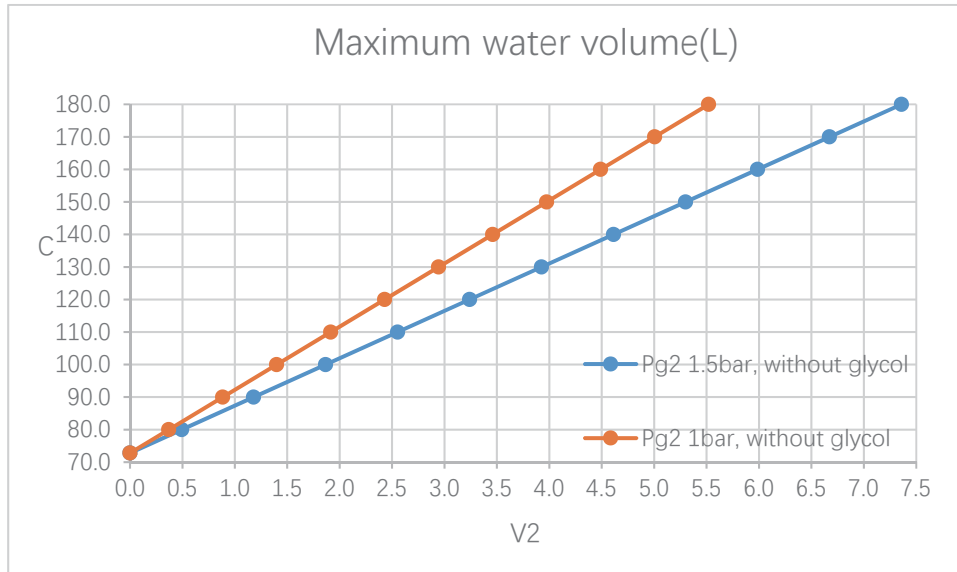

## NOTE

It is recommended to install an expansion vessel for the tapping water side.

### 3.7 Circulation pump

The relationship between the external static pressure (ESP) and the water flow rate is shown as follows:

#### 4-6 kW

Without IBH		With IBH	
ESP (kpa)	Flow rate (m <sup>3</sup> /h)	ESP (kpa)	Flow rate (m <sup>3</sup> /h)
29.6	2.892	25.2	2.753
36.1	2.708	34.8	2.548
43.7	2.49	43.4	2.345
51.2	2.301	52.3	2.15
57.9	2.101	61.1	1.943
65.2	1.901	70.1	1.741
73.1	1.699	77.4	1.547
80.7	1.5	79.9	1.35
85.2	1.297	82.2	1.15
86.8	1.1	83.9	1.03
88	0.901	83.9	0.949
88.5	0.8	85.1	0.75
89.1	0.61	86.1	0.571
89.5	0.376	86.6	0.4

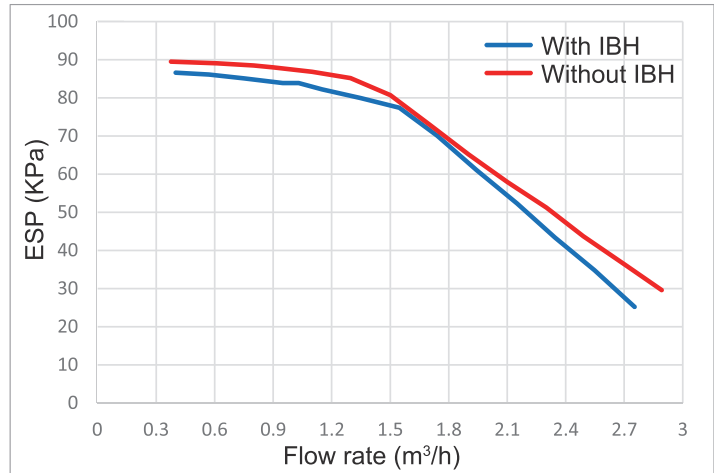

#### 8-10 kW

Without IBH		With IBH	
ESP (kpa)	Flow rate (m <sup>3</sup> /h)	ESP (kpa)	Flow rate (m <sup>3</sup> /h)
		25.6	2.76
31.5	2.79	34.8	2.527
42.1	2.5	41.8	2.348
52.5	2.2	49.3	2.16
63	1.9	57.6	1.951
74.4	1.605	65.9	1.758
83.5	1.3	72.5	1.551
85.3	1	79.5	1.349
86.2	0.7	81.5	1.15
86.4	0.4	82.7	0.896
		83.3	0.691
		83.9	0.49
		84.2	0.4

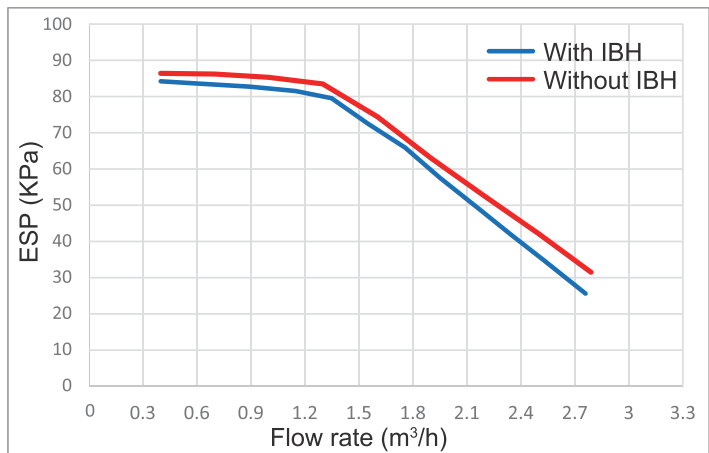

#### 12-16 kW

Without IBH		With IBH	
ESP (kpa)	Flow rate (m <sup>3</sup> /h)	ESP (kpa)	Flow rate (m <sup>3</sup> /h)
23.2	3.47	19.1	2.866
29.1	3.271	22.2	2.796
35.5	3.06	30.8	2.599
41	2.861	39.8	2.377
46.9	2.67	47.2	2.196
52	2.47	56	1.98
58	2.27	63.4	1.806
63.5	2.07	72.9	1.59
69.6	1.87	80.4	1.4
76.3	1.67	82.6	1.187
81.9	1.47	84.4	0.965
86.9	1.27	85.3	0.81
87.6	1.07	86	0.585
88.2	0.87		
88.4	0.67		

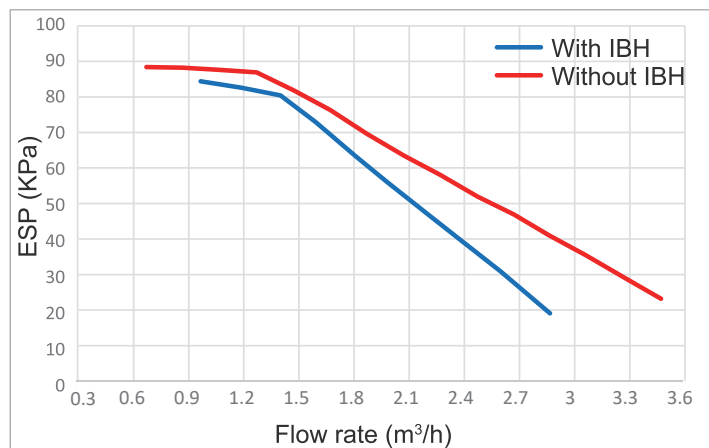



## NOTE

Installing the valves in wrong position can damage the circulation pump.

## CAUTION

If it is necessary to check the running status of the pump with the unit powered on, please do not touch the internal electronic control box components to avoid electric shock.

### 3.8 Thermistor

Table 3-1 lists the temperature sensor in 2.4 Accessories of the unit (the temperature sensor applied in the water loop).

Table 3-1 Temperature sensor resistance characteristics

Temperature (°C)	Resistance (kΩ)	Temperature (°C)	Resistance (kΩ)	Temperature (°C)	Resistance (kΩ)
-10	269.569	30	39.427	70	8.547
-9	255.439	31	37.784	71	8.259
-8	242.131	32	36.219	72	7.983
-7	229.593	33	34.726	73	7.717
-6	217.774	34	33.304	74	7.461
-5	206.63	35	31.947	75	7.215
-4	196.119	36	30.653	76	6.978
-3	186.201	37	29.419	77	6.75
-2	176.84	38	28.241	78	6.531
-1	168.001	39	27.115	79	6.319
0	159.653	40	26.042	80	6.115
1	151.766	41	25.015	81	5.919
2	144.311	42	24.036	82	5.73
3	137.264	43	23.1	83	5.548
4	130.599	44	22.206	84	5.372
5	124.293	45	21.35	85	5.204
6	118.326	46	20.532	86	5.041
7	112.679	47	19.749	87	4.884
8	107.33	48	19.001	88	4.732
9	102.265	49	18.285	89	4.587
10	97.466	50	17.6	90	4.446
11	92.918	51	16.944	91	4.31
12	88.607	52	16.316	92	4.179
13	84.519	53	15.714	93	4.053
14	80.642	54	15.139	94	3.932
15	76.963	55	14.586	95	3.814
16	73.471	56	14.058	96	3.701
17	70.157	57	13.55	97	3.591
18	67.011	58	13.064	98	3.486
19	64.023	59	12.597	99	3.384
20	61.184	60	12.15	100	3.286
21	58.486	61	11.721	101	3.191
22	55.921	62	11.309	102	3.098
23	53.483	63	10.913	103	3.009
24	51.165	64	10.533	104	2.923
25	48.959	65	10.168	105	2.84
26	46.86	66	9.818	106	2.759
27	44.863	67	9.481	107	2.681
28	42.961	68	9.157	108	2.606
29	41.151	69	8.846	109	2.533
				110	2.463

## NOTE

The resistance tolerance is 3 % at 50 °C and 5 % at 25 °C.

### 3.9 Typical Applications

The application examples given below are only for illustration purposes.

### 3.9.1 Controlled through the wired controller

You can set the water temperature, room temperature, and double-zone control on the wired controller. Three options: WATER FLOW TEMP, ROOM TEMP, DOUBLE ZONE (refer to 10.2.5 Temp. type setting).

#### Single-zone control

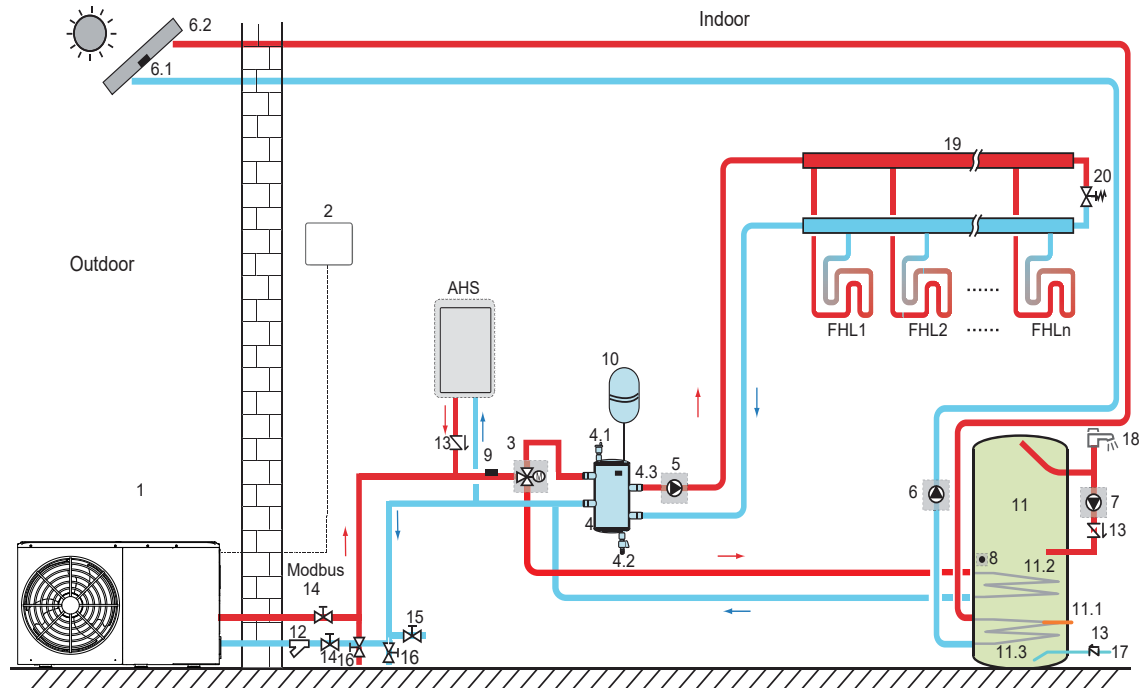

Code	Component/unit	Code	Component/unit
1	Main unit	11	Domestic hot water tank (supplied by the user)
2	Wired Controller	11.1	TBH: domestic hot water tank booster heater (supplied by the user)
3	SV1:3-way valve (supplied by the user)	11.2	Coil 1, heat exchanger for heat pump
4	Balance tank (supplied by the user)	11.3	Coil 2, heat exchanger for solar energy
4.1	Automatic air purge valve	12	Filter (accessory)
4.2	Drainage valve	13	Check valve (supplied by the user)
4.3	Tbt1: upper temperature sensor of balance tank (optional)	14	Shut-off valve (supplied by the user)
5	Pump_O: outside circulation pump (supplied by the user)	15	Filling valve (supplied by the user)
6	Pump_S: solar pump (supplied by the user)	16	Drainage valve (supplied by the user)
6.1	Tsolar: solar temperature sensor (optional)	17	Tap water inlet pipe (supplied by the user)
6.2	Solar thermal collector (supplied by the user)	18	Hot water tap (supplied by the user)
7	Pump_D: DHW pump (supplied by the user)	19	Collector/distributor (supplied by the user)
8	T5: temperature sensor of domestic water tank (accessory)	20	Bypass valve (supplied by the user)
9	T1: Total water flow temperature sensor (optional)	FHL1...n	Floor heating loop (supplied by the user)
10	Expansion vessel (supplied by the user)	AHS	Auxiliary heat source (supplied by the user)

- Space heating

The ON/OFF signal, operation mode, and temperature are set on the wired controller. Pump\_O keeps running as long as the unit is ON for space heating while SV1 remains OFF.

- Domestic water heating

The ON/OFF signal and target tank water temperature (T5S) are set on the wired controller. Pump\_O stops running as long as the unit is ON for domestic water heating while SV1 remains ON.

- AHS (auxiliary heat source) control

The AHS function is set on the HMI (for maintenance personnel).

1) When the AHS is set to be valid only for heating mode, AHS can be turned on in the following ways:

- Turn on the AHS via Backup heater function on the wired controller;
- AHS will be turned on automatically if the initial water temperature is too low or the target water temperature is too high at low ambient temperature.

Pump\_O keeps running as long as the AHS is ON while SV1 remains OFF.

2) The AHS is set to be valid for heating and DHW modes. In heating mode, AHS control is the same as item 1) listed above; In DHW mode, AHS will be turned on automatically when the initial domestic water temperature T5 is too low or the target domestic water temperature is too high at low ambient temperature. Pump\_O stops running while SV1 remains ON.

3) When the AHS is set to be valid, M1M2 can be set to be valid on the wired controller. In heating mode, AHS will be turned on when the M1M2 dry contact closes. This function is invalid in DHW mode.

- TBH (tank booster heater) control

The TBH function is set on the wired controller.

1) When the TBH is set to be valid, TBH can be turned on via Tank heater function on the wired controller; In DHW mode, TBH will be turned on automatically when the initial domestic water temperature T5 is too low or the target domestic water temperature is too high at low ambient temperature.

2) When the TBH is set to be valid, M1M2 can be set to be valid on the wired controller. TBH will be turned on when the M1M2 dry contact closes.

- Solar energy control

The hydraulic module recognizes solar energy signals by judging Tsolar or receiving SL1SL2 signals from the wired controller (See 10.2.7 Other heat source). The recognition method can be set via Solar control on the wired controller. Please refer to 7.6.8 "Wiring of solar energy input signal".

1) When Tsolar is set to be valid, solar energy turns ON when Tsolar is high enough, and Pump\_S starts running; Solar energy turns OFF when Tsolar is low. and Pump\_S stops running.

2) When SL1SL2 control is set to be valid, solar energy turns ON after receiving solar kit signals from the wired controller, and Pump\_S starts running; If no solar kit signals are received, solar energy turns OFF, and Pump\_S stops running.

## Double-zone control

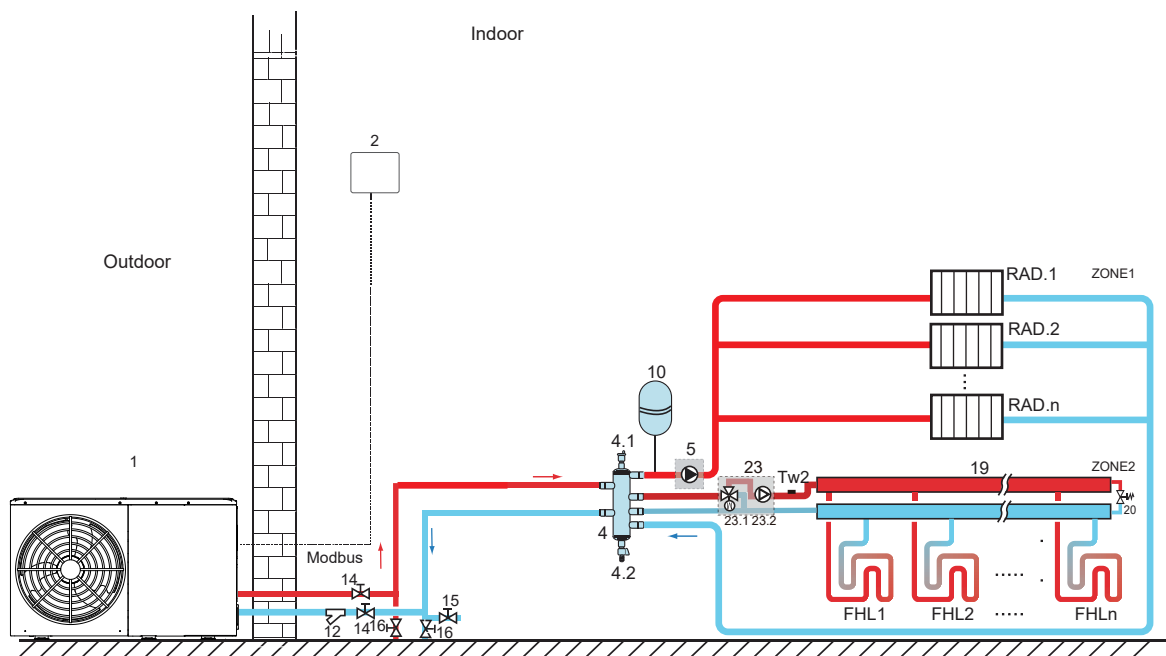

Code	Component/unit	Code	Component/unit
1	Main unit	16	Drainage valve (supplied by the user)
2	Wired controller	19	Collector/distributor (supplied by the user)
4	Balance tank (supplied by the user)	20	Bypass valve (supplied by the user)
4.1	Automatic air purge valve	23	Mixing station (supplied by the user)
4.2	Drainage valve	23.1	SV3: mixing valve (supplied by the user)
5	Pump_O: Zone 1 circulation pump (supplied by the user)	23.2	Pump_C: Zone 2 circulation pump (supplied by the user)
10	Expansion vessel (supplied by the user)	Tw2	Zone 2 water flow temperature sensor (optional)
12	Filter (accessory)	FHL1...n	Floor heating loop (supplied by the user)
14	Shut-off valve (supplied by the user)	RAD.1...n	Radiator (supplied by the user)
15	Filling valve (supplied by the user)		

- Space heating

The general control logic of the unit is same as Single-zone control. SV3 and Pump\_C operates when Zone2 is ON. Zone 2 cannot operate in cooling mode.

• The domestic water tank, AHS (auxiliary heat source), TBH (tank booster heater), and solar control can be connected. The control method is the same as what is described in the above section.

### 3.9.2 Control through the wired controller and room thermostat

Space heating or cooling control through the room thermostat needs to be set on the wired controller. It can be controlled through mode setting, one-zone control or double-zone control. The monoblock can be connected to a high voltage room thermostat and a low voltage room thermostat.

Please refer to 7.6.7 "Wiring of room thermostat" for wiring. See 10.2.6 "Room thermostat setting" for setting.

### Single-zone control

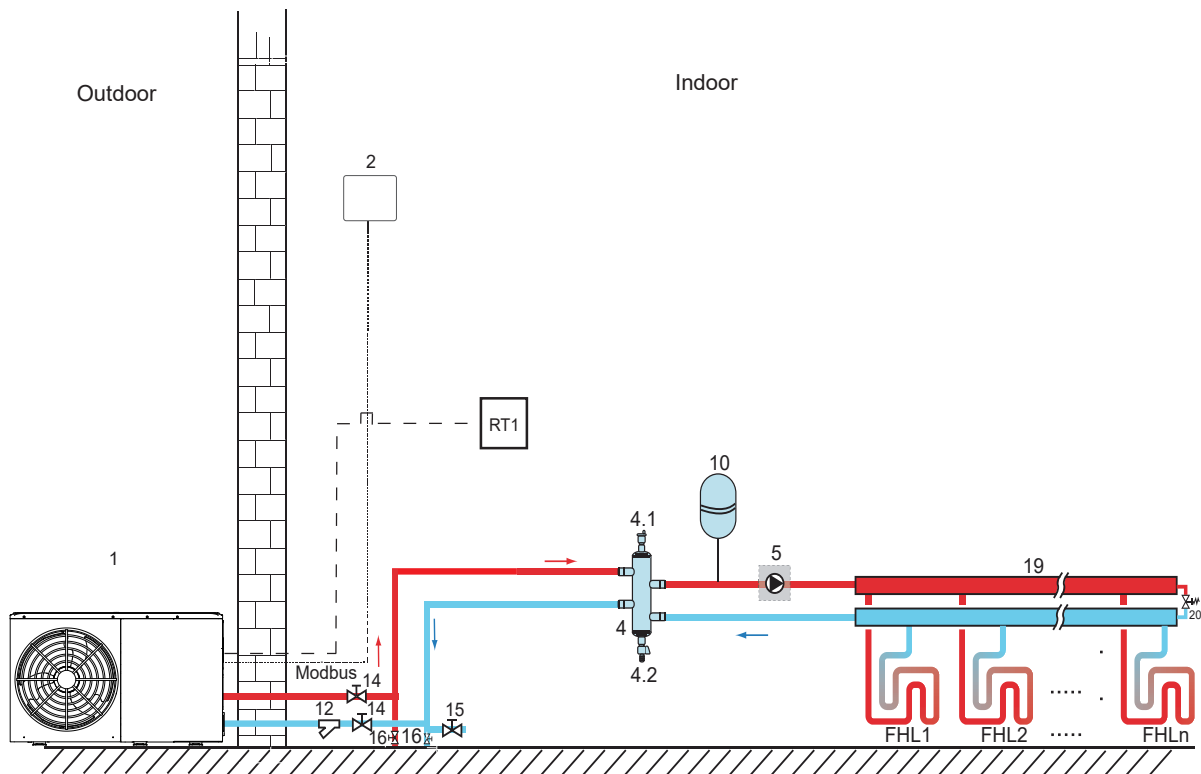

Code	Component/unit	Code	Component/unit
1	Main unit	14	Shut-off valve (supplied by the user)
2	Wired Controller	15	Filling valve (supplied by the user)
4	Balance tank (supplied by the user)	16	Drainage valve (supplied by the user)
4.1	Automatic air purge valve	19	Collector/distributor (supplied by the user)
4.2	Drainage valve	20	Bypass valve (supplied by the user)
5	Pump_O: outside circulation pump (supplied by the user)	RT 1	Low voltage room thermostat (supplied by the user)
10	Expansion vessel (supplied by the user)	FHL 1...n	Floor heating loop (supplied by the user)
12	Filter (accessory)		

- Space heating

One-zone control: the unit ON/OFF is controlled by the room thermostat. The cooling or heating mode and outlet water temperature are set on the wired controller. The system is ON when "HT" of the thermostat closes. When "HT" opens, the system turns OFF.

- Circulation pump operation

When the system turns ON, which means "HT" of the thermostat closes, Pump\_O starts running; When the system turns OFF, which means "HT" opens, Pump\_O stops running.

- The domestic water tank, AHS (auxiliary heat source), TBH (tank booster heater), and solar control can be connected.

The control method is the same as what is described in the above section.

## Control through mode setting

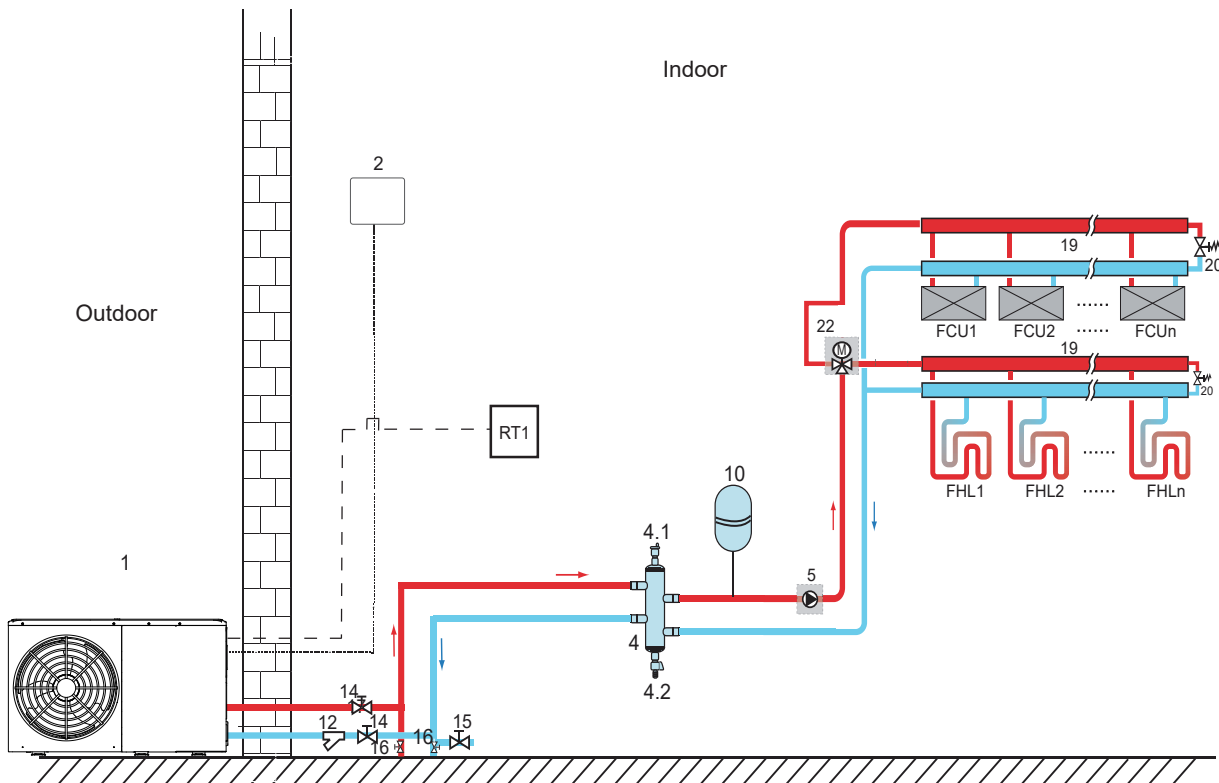

Code	Component/unit	Code	Component/unit
1	Main unit	15	Shut-off valve
2	Wired Controller	16	Drainage valve (supplied by the user)
4	Balance tank (supplied by the user)	19	Collector/distributor
4.1	Automatic air purge valve	20	Bypass valve (supplied by the user)
4.2	Drainage valve	22	SV2: 3-way valve (supplied by the user)
5	Pump_O: outside circulation pump (supplied by the user)	RT 1	Low voltage room thermostat(supplied by the user)
10	Expansion vessel (supplied by the user)	FHL	Floor heating loop (supplied by the user)
12	Filter (accessory)	1...n	
14	Shut-off valve (supplied by the user)	FCU	Fan coil unit (supplied by the user)
		1...n	

- Space heating

The cooling or heating mode is set via the room thermostat, and the water temperature is set on the wired controller.

1) When "CL" of the thermostat closes, the system will be set to work in cooling mode.

2) When "HT" of the thermostat closes and "CL" opens the system will be set to work in heating mode.

- Circulation pump operation

1) When the system is in cooling mode, which means "CL" of the thermostat closes, SV2 remains OFF while Pump\_O starts running.

2) When the system is in heating mode, which means "HT" closes and "CL" opens, SV2 remains ON while Pump\_O starts running.

- The domestic water tank, AHS (auxiliary heat source), TBH (tank booster heater), and solar control can be connected.

The control method is the same as what is described in the above section.

## Double-zone control

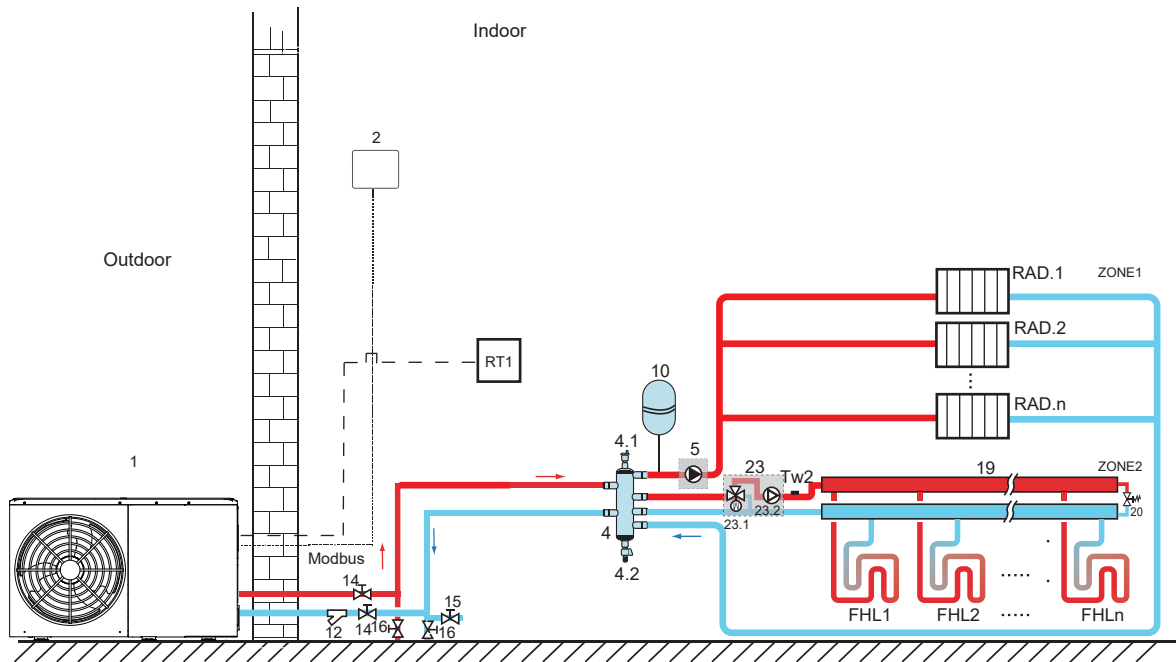

Code	Component/unit	Code	Component/unit
1	Main unit	19	Collector/distributor (supplied by the user)
2	Wired controller	20	Bypass valve (supplied by the user)
4	Balance tank (supplied by the user)	23	Mixing station (supplied by the user)
4.1	Automatic air purge valve	23.1	SV3: Mixing valve (supplied by the user)
4.2	Drainage valve	23.2	Pump_C: Zone 2 circulation pump (supplied by the user)
5	Pump_O: Zone 1 circulation pump (supplied by the user)	RT 1	Low voltage room thermostat (supplied by the user)
10	Expansion vessel (supplied by the user)	Tw2	Zone 2 water flow temperature sensor (optional)
12	Filter (accessory)	FHL	Floor heating loop (supplied by the user)
14	Shut-off valve (supplied by the user)	1...n	
15	Filling valve (supplied by the user)	RAD.	Radiator (supplied by the user)
16	Drainage valve (supplied by the user)	1...n	

- Space heating

Zone1 can operate in cooling mode or heating mode, while Zone2 can only operate in heating mode; During installation, for thermostat in Zone1, only "HT" terminal needs to be connected. For thermostat in Zone2, only "CL" terminal needs to be connected.

1) The ON/OFF of Zone1 is controlled by the room thermostat there. When "HT" of thermostat in Zone1 closes, Zone 1 turns ON. When "HT" opens, Zone 1 turns OFF; The target temperature and operation mode are set on the wired controller.

2) In heating mode, the ON/OFF of Zone2 is controlled by the room thermostat there. When "CL" of thermostat in Zone2 closes, Zone 2 turns ON; Zone 2 can only operate in heating mode. When cooling mode is set on the wired controller, Zone2 remains OFF.

- Circulation pump operation

When Zone1 turns ON, Pump\_O starts running; When Zone1 turns OFF, Pump\_O stops running;

When Zone2 turns ON, SV3 switches between ON and OFF according to the set Tw2, and Pump\_C remains ON; When Zone 2 turns OFF, SV3 remains OFF and Pump\_C stops running.

The floor heating loops require a lower water temperature in heating mode than radiators or fan coil units. To reach the set temperature points, a mixing station is used to adapt the water temperature according to requirements of the floor heating loops. The radiators are directly connected to the unit's water loop and the floor heating loops and after the mixing station. The mixing station is controlled by the unit.

- The domestic water tank, AHS (auxiliary heat source), TBH (tank booster heater), and solar control can be connected.

The control method is the same as what is described in the above section.

### 3.9.3 Cascade system

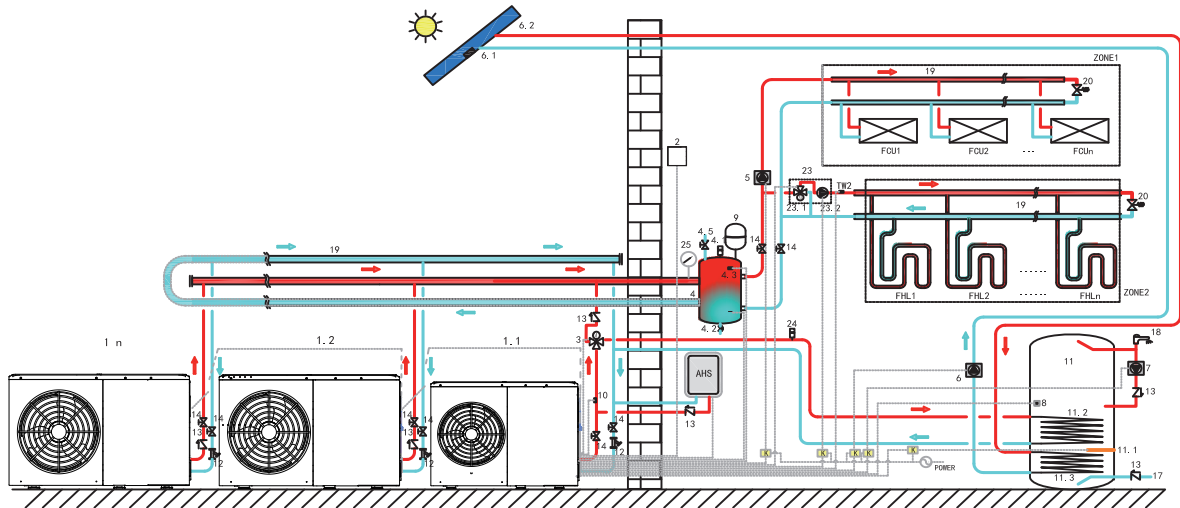

Code	Component/unit	Code	Component/unit	Code	Component/unit
1.1	Master unit	5	Pump_O: outside circulation pump (supplied by the user)	11.1	TBH: domestic hot water tank booster heater
1.2...n	Slave unit	6	Pump_S: solar pump (supplied by the user)	11.2	Coil 1, heat exchanger for heat pump
2	Wired controller	6.1	Tsolar: solar temperature sensor (optional)	11.3	Coil 2, heat exchanger for solar energy
3	SV1: 3-way valve (supplied by the user)	6.2	Solar thermal collector (supplied by the user)	12	Filter (accessory)
4	Balance tank (supplied by the user)	7	Pump_D: DHW pipe pump (supplied by the user)	13	Check valve (supplied by the user)
4.1	Automatic air purge valve	8	T5: domestic water tank temperature sensor (accessory)	14	Shut-off valve (supplied by the user)
4.2	Drainage valve	9	Expansion vessel (supplied by the user)	17	Tap water inlet pipe (supplied by the user)
4.3	Tbt1: upper temperature sensor of balance tank (optional)	10	T1: total water flow temperature sensor (optional)	18	Hot water tap (supplied by the user)
4.5	Filling valve	11	Domestic hot water tank (supplied by the user)	19	Collector/distributor (supplied by the user)

20	Bypass valve (supplied by the user)	25	Water manometer (supplied by the user) Zone 1	ZONE1	Only heating mode is applicable to the space
23	Mixing station (supplied by the user)	TW2	Zone 2 water flow temperature sensor (optional)	ZONE2	Only heating mode is applicable to the space
23.1	SV3: mixing valve (supplied by the user)	FCU1...n	Fan coil unit (supplied by the user)	AHS	Auxiliary heat source (supplied by the user)
23.2	Pump_C: Zone 2 circulation pump (supplied by the user)	FHL1...n	Floor heating loop (supplied by the user)		
24	Automatic air purge valve (supplied by the user)	K	Contactora (supplied by the user)		

- **Domestic water heating**

Only the master unit (1.1) can operate in DHW mode. T5S is set on the wired controller (2). In DHW mode, SV1(3) remains ON. When the master unit operates in DHW mode, the slave units can operate in space cooling/heating mode.

- **Heating mode of slave units**

All slave units can operate in space heating mode. The operation mode and temperature are set on the wired controller (2). Due to changes of the outdoor temperature and the required load indoors, multiple outdoor units may operate at different time points.

In cooling mode, SV3(23.1) and Pump\_C (23.2) remains OFF while Pump\_O(5) remains ON.

In heating mode, when both Zone 1 and Zone 2 work, Pump\_C (23.2) and Pump\_O (5) remain ON, and SV3 (23.1) switches between ON and OFF according to the set Tw2.

In heating mode, when only Zone 1 works, Pump\_O (5) remains ON while SV3 (23.1) and Pump\_C (23.2) remain OFF.

In heating mode, when only Zone 2 works, Pump\_O (5) remains OFF while Pump\_C (23.2) remains ON, and SV3 (23.1) switches between ON and OFF according to the set TW2.

- **AHS (auxiliary heat source) control**

The AHS should be set in For serviceman mode. The AHS is only controlled by the master unit. When the master unit operates in DHW mode, the AHS can only be used for producing domestic hot water; When the master unit operates in heating mode, the AHS can only operate in heating mode.

1) When the AHS is set to be valid only in heating mode, it will be turned on in the following conditions:

a. The Backup heater function is enabled on wired controller;

b. The master unit operates in heating mode. When the inlet water temperature or ambient temperature is too low while the target leaving water temperature is too high, the AHS will be turned on automatically.

2) When the AHS is set to be valid in heating mode and DHW mode, it will be turned on in following conditions:

When the master unit operates in heating mode, conditions for turning on the AHS is same as 1); When the master unit operates in DHW mode, if T5 or the ambient temperature is too low while the target T5 temperature is too high, the AHS will be turned on automatically.

3) When the AHS is valid, the operation of the AHS is controlled by M1M2. When M1M2 closes, the AHS is turned on.

When the master unit operates in DHW mode, the AHS can not be turned on by closing M1M2.

- **TBH (tank booster heater) control**

The TBH should be set in For serviceman mode. The TBH is only controlled by the master unit. Please refer to 3.9.1 for specific TBH control.

- **Solar energy control**

Solar energy is only controlled by the master unit. Please refer to 3.9.1 for specific solar energy control.

### **NOTE**

1. Maximum 6 units can be cascaded the system. The unit with wired controller is master unit, units without wired controller are slave units; Only master unit can operate in DHW mode. While installation, please check the cascade system diagram and determine the master unit; Before powering on, remove all wired controllers of slave units.

2. SV1, SV2, SV3, Pump\_O, Pump\_C, Pump\_S, T1, T5, Tw2, Tbt, Tsolar, SL1SL2, AHS, TBH interface are only connected to corresponding terminals on main board of master unit.

3. The address code of the slave unit needs to be set on the hydraulic module PCB board DIP-switch (See wiring diagram on the unit). All slave address codes cannot be the same, and cannot be 0#.

4. It is suggested to use the reversed return water system in order to avoid hydraulic imbalance between each unit in a cascade system.

### **NOTE**

1. In a cascade system, the Tbt sensor must be connected to a master unit, and Tbt must be set to valid on the wired controller. Otherwise, all slave units will not work.

2. If the outside circulation pump needs to be connected in series in the system when the head of internal water pump is not enough, outside circulation pump is suggested to be installed after the balance tank.

3. Please ensure that the maximum interval of power-on time of all units doesn't exceed 2 minutes, which may cause the slaves to fail to communicate normally.

4. The outlet pipe of each unit must be installed with a check valve.



## 4 SAFETY ZONE

The refrigerant circuit in the outdoor unit contains easily flammable refrigerant in safety group A3 as described in ISO 817 and ANSI/ASHRAE Standard 34. Therefore, a safety zone is defined in the immediate vicinity of the outdoor unit, in which special requirements apply. Note that this refrigerant has a higher density than air. In the event of a leak, escaping refrigerant may be collected near the earth. The following conditions must be avoided within the safety zone:

- Building openings such as windows, doors, light wells, and flat roof windows;
- Outdoor air and exhaust air apertures of ventilation and air conditioning systems;
- Property boundaries, neighboring properties, footpaths, and driveways;
- Pump shafts, inlets to waste water systems, downpipes, and waste water shafts, etc.;
- Other slopes, troughs, depressions, and shafts;
- Electrical house supply connections;
- Electrical systems, sockets, lamps, and light switches; Snowfall from roofs.

Do not introduce ignition sources into the safety zone:

- Naked flames or burner gauze assemblies.
- Grills.
- Tools that generate sparks.
- Electrical devices not free of ignition sources, mobile devices with integrated batteries (such as mobile phones and fitness watches).
- Objects with a temperature of above 360 °C.

### NOTE

The particular safety zone is dependent on the surroundings of the outdoor unit.

- The safety zones below are shown with floor standing installation. These safety zones also apply to other types of installation.

Freestanding positioning of the outdoor unit

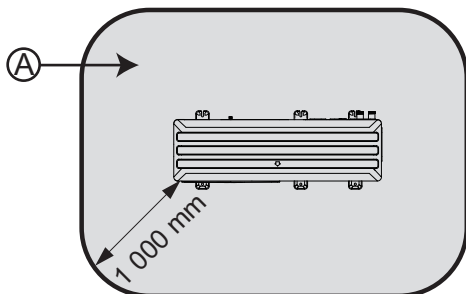

(A) Safety zone

Siting the outdoor unit in front of an external wall

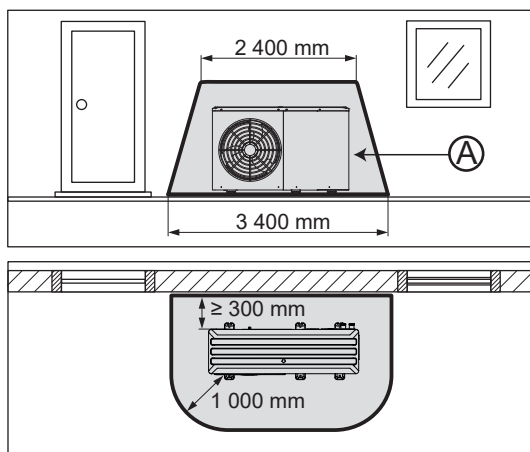

(A) Safety zone

Corner positioning of the outdoor unit, left

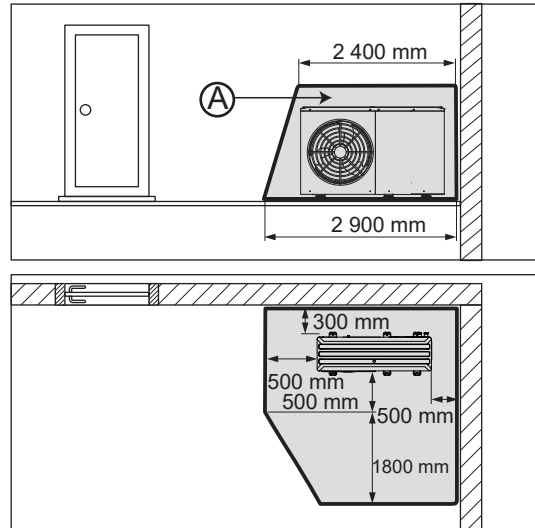

## 5 UNIT INSTALLATION

### 5.1 General rules

In addition to "Safety zone", the following conditions should be observed.

#### Environment

- For the sake of safety and unit performance, the installation site must be with sufficient air flow.
- For maintenance and service purposes, the installation site should be highly accessible.
- Impact protection measures should be taken, if the installation site has high impact risks, such as a vehicle shunting area.
- Keep the unit away from flammable substances or flammable gases.
- Keep the unit away from heat sources.
- Keep the unit as far away from raindrops as possible.
- Do not expose the outdoor unit to any dirty, dusty or corrosive atmosphere.
- Keep the unit away from ventilation openings or ventilation ducts.

#### Nature

Be ware of the impact from the nature:

- Plants with vines could block the air inlet and outlet of the unit as they grow.
- Fallen leaves could block the unit air inlet or stuck the air channel.
- Insects, snakes or some small animals might enter the unit. Wild animals might bite or damage the piping and wiring of the unit.

### NOTE

In case of any evidence of animal effects, ask professionals for inspection and maintenance.

#### Strong wind

- When installing the unit in a place exposed to strong wind, pay special attention to the following:  
A wind speed of 5 m/s or higher against the unit's air outlet could cause a short circuit (suction of discharge air), which may have the following consequences:
  - Deterioration of the operational capacity.
  - Frequent frosting in heating operation.
  - Disruption of operation due to pressure rise.
- When strong wind blows continuously on the front of the unit, the propeller could start rotating very fast until it breaks.

## Noise impact

- Select an installation site that is as far away from living rooms and bedrooms as possible.
- Please note the noise emissions. Select an installation site that is as far away from the windows of adjacent buildings as possible.

## Installation by the sea

- If the installation site is in the immediate vicinity of a coastline, ensure that the product is protected against spraying water by an additional protection device.
- Wind from the sea brings saline substances to the land. This could have negative impacts on the unit due to long-time exposure to the saline substances. To prolong the lifetime of the unit, ask professionals for a customized maintenance proposal, and follow the proposal.

## Altitude

- The unit is designed to be used below 2000 m of altitude. If it is installed above this level, its performance and reliability cannot be guaranteed.

## 5.2 Installation site

The product is suitable for installation on a ground, wall or flat roof.

### NOTE

Installation on a pitched roof (inclined place) is not permitted.

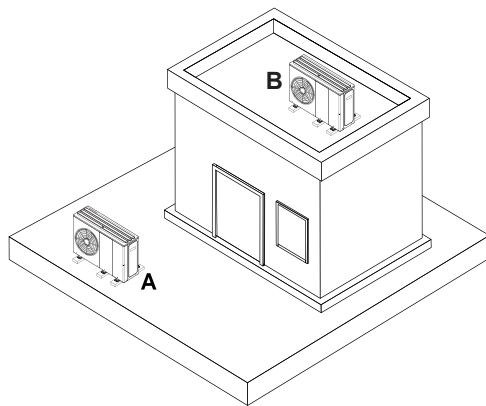

(A) Installation on a ground  
(B) Installation on a flat roof

### 5.2.1 Precautions for installation on a ground

- Avoid any installation site that is in the corner of a room, between walls or between fences.
- Prevent the return intake of air from the air outlet.
- Ensure that water cannot accumulate on the subsoil.
- Ensure that the subsoil can absorb water well.
- Plan a bed of gravel and rubble for the condensate discharge.
- Select an installation site that is free from significant accumulations of snow in winter.
- Select an installation site at which the air inlet is not affected by strong wind. Position the unit crosswise to the wind direction whenever it is possible.
- If the installation site is not protected against wind, a protective wall is required.
- Please note the noise emissions. Avoid corners of rooms, recesses or sites between walls.
- Select an installation site with excellent sound absorption performance such as those with grass, hedges or fencing.
- Route the hydraulic lines and electrical wires underground.
- Provide a safety pipe that leads from the outdoor unit through the wall of the building.

### 5.2.2 Precautions for installation on a flat roof

- Only install the product in a building with a solid construction structure and that has cast concrete ceilings throughout.
- Do not install the product in any building with a wooden structure or with a lightweight roof.
- Select an installation site that is easily accessible so that foliage or snow can be regularly removed from the product.
- Select an installation site at which the air inlet is not affected by strong wind. Position the unit crosswise to the wind direction whenever it is possible.
- If the installation site is not protected against wind, a protective wall is required.
- Please note the noise emissions. Maintain a sufficient clearance from adjacent buildings.
- Route the hydraulic lines and electrical wires.
- Provide a wall duct.

### 5.2.4 Occupational safety

#### Installation on a flat roof

- Ensure that the flat roof can be safely accessed.
- Maintain a safety area that is 2 m from falling edges, and a clearance that is required for working on the product. The safety area must be inaccessible.
- If this is not possible, install technical falling protections at the falling edges such as reliable railings. Alternatively, set up technical safety equipment such as scaffolding or safety nets.
- Maintain a sufficient clearance from any roof escape hatches and flat-roof windows. Use suitable protective equipment (e.g. barriers) to prevent people from stepping on or falling through any escape hatches and flat-roof windows.

## 5.3 Foundation and unit installation

### 5.3.1 Installation on a ground

#### Installation on a soft ground

In case of installation on a soft ground such as lawn and soil, create a foundation as shown in the figure below.

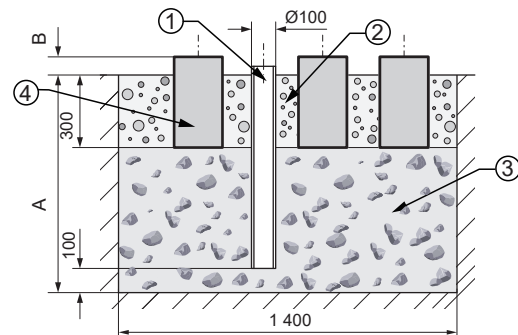

- 1) Downpipe for drainage
- 2) Strip foundations
- 3) Water-permeable coarse rubble
- 4) Concrete strip foundations

- Dig a hole in the ground. For the location of the downpipe, refer to 5.4.1 Drain hole position.
- Insert a downpipe (1) to divert the condensate.
- Add a layer of water-permeable coarse rubble (3).
- Calculate the depth (A) in accordance with local conditions.
- Region with ground frost: minimum depth: 900 mm
- Region without ground frost: minimum depth: 600 mm
- Calculate the height (B) in accordance with local conditions. Such height should not be smaller than 100 mm.
- Create three concrete strip foundations (4). The recommended dimensions can be found in the figure.
- Make sure the three foundations are level.
- There are no restrictions on the width or length of the foundations, provided that the unit can be mounted on the foundation properly and the downpipe for drainage is not blocked.

- Add a gravel bed between and beside the strip foundations (2) to divert the condensate.

### Installation on a solid ground

In case of installation on a solid ground such as concrete, create a concrete strip foundation comparable to what is described in the section above. The height of the strip foundation should not be smaller than 100 mm.

### Unit mounting

Installation with foundation: Fix the unit with foundation bolts. (Six  $\Phi$  10 expansion bolts, nuts and washers are needed, supplied on the site). Screw the foundation bolts to a depth of 20 mm in the foundation.

Installation without foundation: Install proper anti-vibration pads and level the unit.

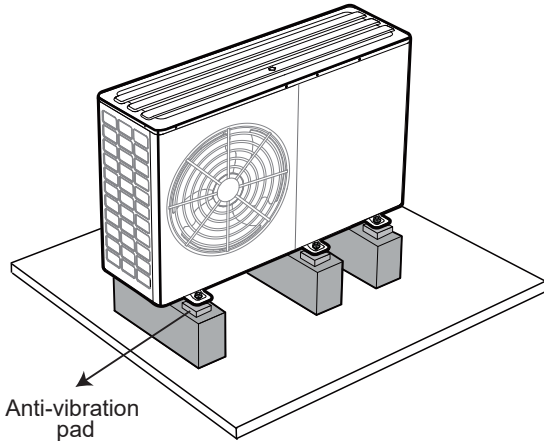

### CAUTION

All six feet must be fixed.

### 5.3.2 Installation on a flat roof

In case of installation on a flat roof, create a concrete strip foundation comparable to what is described in 5.3.1 Installation on a ground. The height of the strip foundation should not be smaller than 100 mm.

- Take drainage layout into consideration, and install the unit close to the drainage.

### Unit mounting

Same as 5.3.1 Installation on a ground.

## 5.4 Drainage

### 5.4.1 Drain hole position

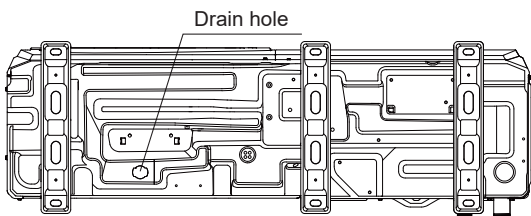

4/6 kW

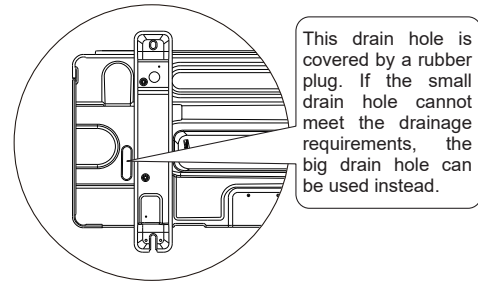
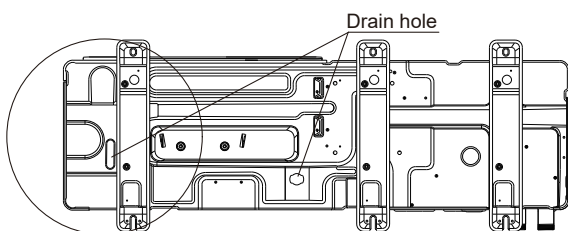

This drain hole is covered by a rubber plug. If the small drain hole cannot meet the drainage requirements, the big drain hole can be used instead.

8/10/12/14/16 kW

### CAUTION

- Watch the condensate when removing the rubber plug of the additional drain hole.
- Make sure the condensate is drained properly. Collect and direct the condensate that can drip from the base of the unit to a drain tray. Prevent water dripping onto the floor that may generate a slip hazard, especially in winter.
- For cold climate, it is highly recommended that a belt heater be installed to avoid damage to the unit due to the drain water freezing in case of a low drainage rate.

### 5.4.2 Drainage layout (installation on a ground)

#### Drain joint

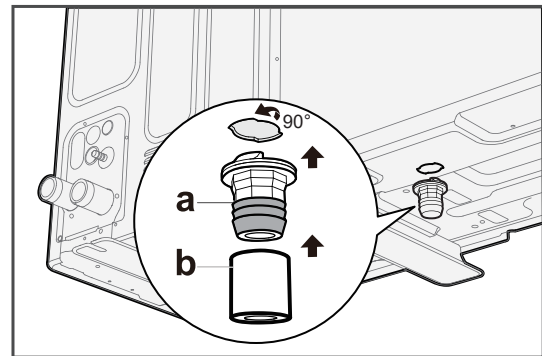

a – Drain joint (plastic, Pagoda connection, 1")

b - Drain hose (field supply)

#### Installation on a soft ground

##### Draining condensate into a gravel bed

For installation on a ground, the condensate must be discharged via a downpipe into a gravel bed that is located in a frost-free area.

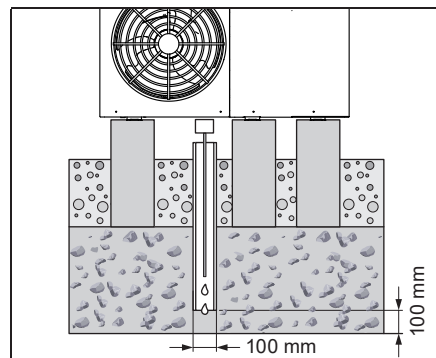

The downpipe must go into a sufficiently large gravel bed so that the condensate can trickle away freely.

### NOTE

To prevent the condensate from freezing, self-regulating heating cable(field supply) must be threaded into the downpipe so that the condensate can discharge via the downpipe.

#### Draining condensate through a pump sump/soakaway

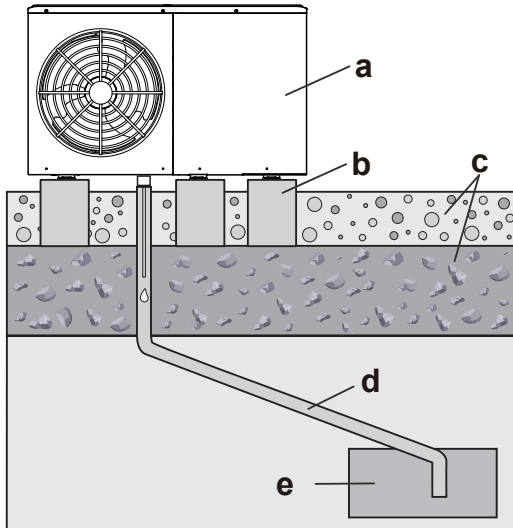

- a - Outdoor unit
- b - Concrete strip foundations
- c - Foundation (See 5.3.1 Installation on a ground)
- d - Drain pipe(at least DN 40)
- e - Pump sump/soakaway

#### Sewer

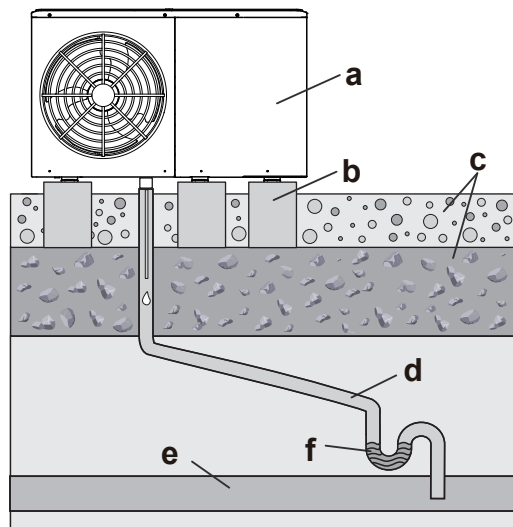

- a - Outdoor unit
- b - Concrete strip foundations
- c - Foundation (See 5.3.1 Installation on a ground)
- d - Drain pipe (at least DN 40)
- e - Sewer
- f - Stench trap in an area free from frosting risks

#### Installation on a solid ground

Guide the condensation pipe to a sewer, pump sump or soakaway.

The drain plug in the accessory pack cannot bend to another direction. For this, use a hose to guide the condensate into a sewer, pump sump or soakaway through a gully, balcony run-off or roof run-off.

Open gullies within the safety zone do not pose any safety risk.

#### Installation on a flat roof

Refer to Installation on a solid ground.

### NOTE

- For all installation types, ensure that any condensate that accumulates is discharged into a frost-free area.
- To prevent the condensate from freezing, self-regulating heating cable(field supply) can be threaded into the downpipe so that the condensate can discharge via the downpipe.

#### 5.5 In cold climates

It is recommended that the unit be placed with the rear side against the wall.

Install a lateral canopy on top of the unit to prevent lateral snowfall in extreme weather conditions.

Install a high pedestal or wall mount the unit to keep a proper clearance (at least 100 mm) between the unit and snow.

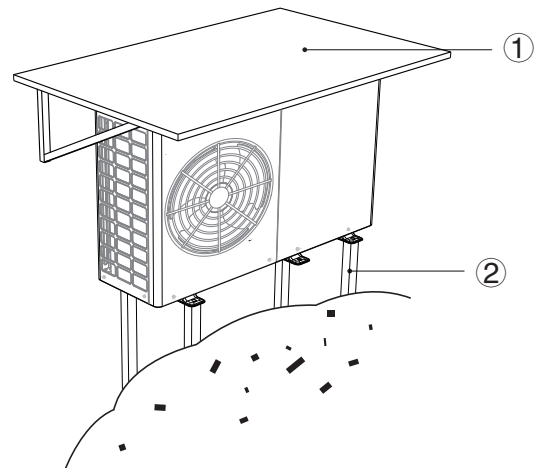

- ① Canopy or alike
- ② Pedestal in case of installation on a ground

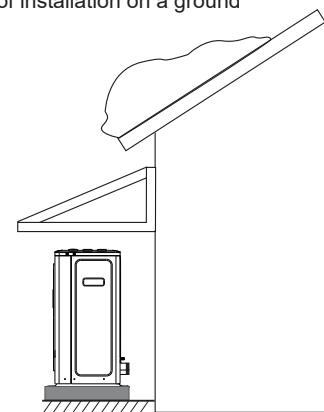

If there is a risk of snow slip from the roof, a protective roof or cover must be erected to protect the heat pump, pipes and wiring.

#### 5.6 Exposure to Strong Sunlight

Long time of exposure of the ambient temperature sensor of the unit to sunlight might impact the sensor negatively, and cause undesirable impacts on the unit. Shade the unit with a canopy or alike.

## 6 HYDRAULIC INSTALLATION

### 6.1 Preparations for installation

#### NOTE

- In case of plastic pipes, make sure they are fully oxygen-tight according to DIN 4726.
- The diffusion of oxygen into the piping can lead to excessive corrosion.

#### 6.1.1 Minimum water volume

Verify that the total water volume in the installation is at least 40L, excluding the internal water volume of the outdoor unit.

#### NOTE

- Extra water might be required in critical processes or in rooms with a high heating load.
- When circulation in each space heating/cooling loop is controlled by remotely controlled valves, it is necessary to guarantee the minimum water volume, even if all of the valves are closed.

#### 6.1.2 Flow rate range

Verify that the minimum flow rate in the installation is guaranteed in all conditions. This rate is required during defrosting/ backup heater operation.

#### NOTE

- When one or more heating circuits are controlled by remotely controlled valves, the minimum water flow needs to be guaranteed, even if all valves are closed. If the minimum flow rate cannot be satisfied, E0 and E8 (unit shutdown) will be triggered.

Unit	Flow rate range(m <sup>3</sup> /h)
4 kW	0.40* - 0.90
6 kW	0.40* - 1.25
8 kW	0.40* - 1.65
10 kW	0.40* - 2.10
12 kW	0.70* - 2.50
14 kW	0.70* - 2.75
16 kW	0.70* - 3.00

\* The minimum output of the Pump\_I can be set on wired controller.

#### CAUTION

- The heat exchanger could be damaged by freezing water due to low water flow rate.

#### 6.1.3 Pre-pressure adjustment of the expansion vessel

The unit is equipped with an expansion vessel of 8 L that has a default pre-pressure of 1.5 bar. Check the pre-pressure every two years.

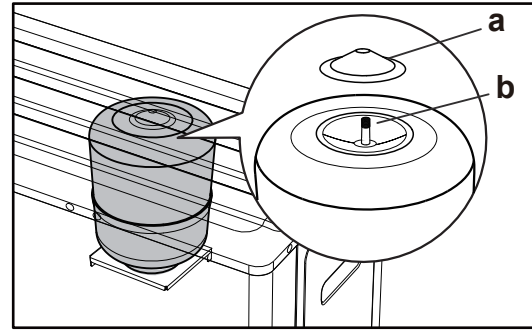

a – Top cover  
b - Schrader valve

#### 6.1.4 Requirements for third-party tanks

A third-party tank, if used, should meet the following requirements:

- The heat exchanger coil of the tank is  $\geq 1.05 \text{ m}^2$ ,  $1.94 \text{ m}^2$  is recommended.
- The tank thermistor must be located above the heat exchanger coil.
- The booster heater must be located above the heat exchanger coil.
- Notice the pressure loss of the tank, mount an additional water pump when it is needed.

#### NOTE

##### • Performance

Performance data for third-party tanks is unavailable, and the performance CANNOT be guaranteed.

##### • Configuration

Configuration of a third-party tank depends on the size of the heat exchanger coil of the tank.

For installation of the domestic hot water tank (supplied by the user), refer to the specific manual of the domestic hot water tank.

#### 6.1.5 Thermistor of domestic hot water tank

The maximum allowable thermistor cable length is 20 m, which is equal to the maximum allowable distance between the domestic hot water tank and the unit (only for installation with a domestic hot water tank). The thermistor cable supplied with the domestic hot water tank is 10 m in length.

#### 6.1.6 Requirements for balance tank volume

For balance tank selection, refer to 3.5 Balance tank.

#### 6.1.7 Field connection of hydraulics parts

#### NOTE

- When a 3-way valve is to be used in the water loop, a ball valve is recommended to guarantee full separation between the domestic hot water loop and the floor heating water loop.
- When a 3-way valve or a 2-way valve is used in the water loop, the recommended valve changeover time is less than 60 seconds.
- To optimize unit efficiency, you are advised to install the 3-way valve and the domestic hot water tank as close as possible to the unit.

## 6.2 Water loop connection

### Typical workflow

Connecting the water loop typically consists of the following steps:

- 1) Connect the water piping to the outdoor unit.
- 2) Connect the drain hose to the drain.
- 3) Fill the water loop.
- 4) Fill the domestic hot water tank (if available).
- 5) Insulate the water piping.

## Requirements

### NOTE

- The pipe inside must be clean.
- Hold the pipe end downwards when removing burrs.
- Cover the pipe end when inserting the pipe through a wall to prevent dust and dirt from entering the pipe.
- Use proper thread sealant to seal the connections. The sealing must be able to withstand the pressure and temperature of the system.
- When using non-copper metallic piping, be sure to insulate two kinds of materials from each other to prevent galvanic corrosion.
- Copper is soft. Use appropriate tools to avoid damage.
- Zn-coated parts cannot be used.
- Always use materials that do not react with the water used in the system and with the materials used in the unit.
- Ensure that components installed in the field piping can withstand the water pressure and temperature.

### CAUTION

- Incorrect direction of the water outlet and inlet can cause unit malfunction.
- Do not apply excessive force when connecting the pipes provided on the site, and make sure the pipes are aligned properly. Water pipe deformation can cause unit malfunction.
- The unit is only to be used in a closed water system (See 3.9 Typical Applications).

- 1) Connect the Y-Type strainer to the water inlet of the unit, and seal the connection with thread sealant. (To provide access to the Y-Type strainer for cleaning, an extension pipe can be connected between the strainer and the water inlet depending on the field conditions)
- 2) Connect the pipe provided on the site to the water outlet of the unit.
- 3) Connect the outlet of the safety valve with a hose with a suitable size and length, and guide the hose to the condensate 5.4.2 Drainage layout.

#### 4-6 kW

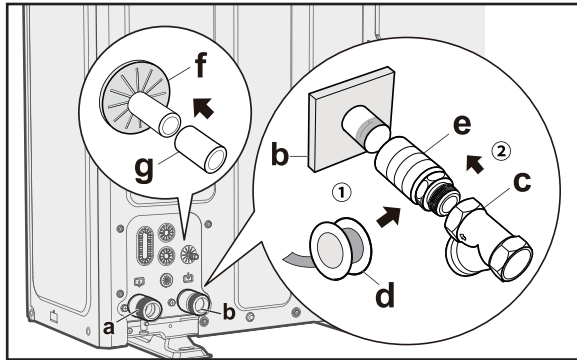

#### 8-16 kW

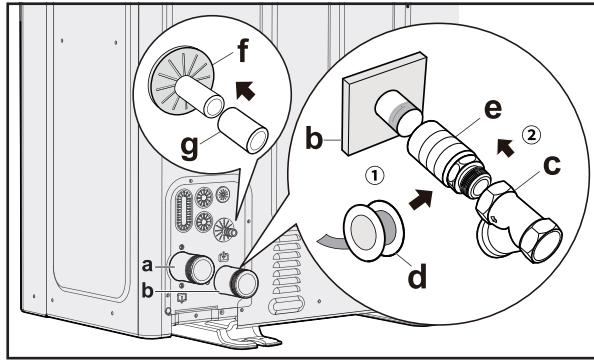

a	Water OUTLET (connection with screws, male, 1" for 4/6 kW units and 1 1/4" for 8-16 kW units)
b	Water INLET (connection with screws, male, 1" for 4/6 kW units and 1 1/4" for 8-16 kW units)
c	Y-Type strainer (delivered with the unit) (2 screws for connection, female, 1" for 4/6 kW units and 1 1/4" for 8-16 kW units)
d	Thread seal tape
e	Extension pipe (recommended, with the length depending on the field conditions)
f	Safety valve outlet (hose, φ16 mm)
g	Drain hose (supplied on the site)

### CAUTION

- The installation of the Y-type strainer at the water inlet is mandatory
- Pay attention to the correct flow direction of the Y-type strainer.
- Sediment may damage the plate heat exchanger, and there could be refrigerant leakage risk without strainer.
- It is recommended to use strainer with 60 mesh or higher.

### NOTE

Problems caused by not installing a filter are not covered by the warranty.

## Domestic hot water

For the installation of the domestic hot water tank (supplied on the site), refer to the specific manual of the domestic hot water tank.

### Others

#### NOTE

- Air vent valves must be installed at highest points of the system.
- Drain taps must be installed at lowest points of the system.

## 6.3 Water

#### NOTE

- Circulators function well exclusively with clean and high-quality tap water.
- Risk of material damage due to poor-quality water.
- The most frequent factors that can affect circulators and the system are oxygen, limescale, sludge, acidity level and other substances (including chlorides and minerals).
- In addition to the quality of water, installation also plays an important role. The heating system must be airtight. Choose materials that are not sensitive to oxygen diffusion (risk of corrosion...).

### Characteristics of the water

- Compliant with local regulations.
- Langelier Index (LI) between 0 and + 0.4.
- Within the limits indicated in the chart.

Water quality must be checked by qualified personnel.

### Hardness

If the water is hard, install a system suitable to preserve the unit from harmful deposits and limestone formation.

#### NOTE

If necessary, fit a water softener to reduce water hardness.

### Cleanliness

Before connecting the water to the unit, clean the system thoroughly with specific products effective to remove residues or impurities that may affect functioning. Existing systems must be free from sludge and contaminants and protected against buildups.

### New systems

In case of new installations, it is essential to wash the entire installation (with the circulator uninstalled) before commissioning the central installation. This removes residues of the installation process (welding, waste, joint products...) and preservatives (including mineral oil). The system must then be filled with clean high-quality tap water.

### Existing systems

If a new boiler or heat pump is installed on an existing heating system, the system must be rinsed to avoid the presence of particles, sludge and waste. The system must be drained before installing the new unit. Dirt can be removed only with a suitable water flow. Each section must then be washed separately.

Particular attention must also be paid to “blind spots” where a lot of dirt can accumulate due to the reduced water flow. The system must then be filled with clean high-quality tap water. If, after rinsing, the quality of the water is still unsuitable, a few measures must be taken to avoid problems. An option to remove pollutants is to install a strainer. Various types of strainers are available. A mesh strainer is designed to catch large dirt particles. This strainer is usually placed in the part with the larger flow. A tissue strainer is designed to catch the finer particles.

### Water component for corrosion limit on copper

PH	7.5-9.0	
Ryznar Stability Index (RSI)	< 6.0	
Electric conductivity	100-500	µS/cm
Total Hardness	4.5-8.5	dH
Max. quantity glycol	40	%
Sulfate ions (SO <sub>4</sub> )	< 50	ppm
Alkalinity (HCO <sub>3</sub> )	70-300	ppm
Chloride ions (Cl <sup>-</sup> )	< 50	ppm
Phosphates (PO <sub>4</sub> )	< 2.0	ppm
NH <sub>3</sub>	< 0.5	ppm
Iron (Fe)	< 0.3	ppm
Manganese (Mn)	< 0.05	ppm
Sulfate ions (S)	None	
Ammonium ions (NH <sub>4</sub> )	None	
Silica (SiO <sub>2</sub> )	< 30	ppm
CO <sub>2</sub>	< 50	ppm
Oxygen content	< 0.1	ppm
Sand	< 10 mg/L, 0.1 to 0.7mm max diameter	
Ferrite hydroxide Fe <sub>3</sub> O <sub>4</sub> (black)	Dose < 7.5 mg/L, 50 % of mass, with diameter < 10 µm	
Iron oxide Fe <sub>2</sub> O <sub>3</sub> (red)	Dose < 7.5 mg/L, diameter < 1 µm	

## 6.4 Filling water loop with water

#### NOTE

Before filling with water, please check 6.3 Water for the water quality requirements. Pumps and valves may become stuck as a result of poor water quality.

- Connect the water supply to the filling valve and open the valve. Follow applicable regulations.
- Make sure the automatic air vent valve is open.
- Ensure a water pressure of approximately 0.2 MPa(2 bar). Remove the air in the loop as much as possible using the air vent valves. Air in the water loop could lead to malfunction of the backup electric heater.

Do not fasten the black plastic cover on the vent valve at the top side of the unit when the system is running. Open the air vent valve, and turn it anticlockwise at least 2 full turns to release air from the system.

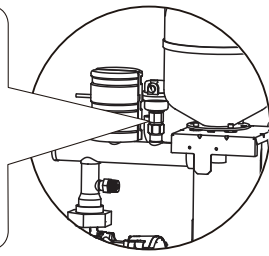

### NOTE

During filling, it might not be possible to remove all air from the system. Remaining air will be removed through the automatic air purge valves during the first operation of the system.

Topping up with water afterwards might be required.

- The water pressure varies with the water temperature (higher pressure at higher water temperature). Always keep the water pressure above 0.03 MPa(0.3 bar) to prevent air from entering the loop.
- The unit might drain off too much water through the pressure relief valve.

Maximum water pressure	0.3 MPa(3 bar)
------------------------	----------------

## 6.5 Filling domestic hot water tank with water

See the specific manual of the domestic hot water tank.

## 6.6 Water pipe insulation

The complete water loop including all pipes, must be insulated to prevent condensation during cooling operation, heating and cooling capacity reduction, and freezing of the outside water pipes in winter.

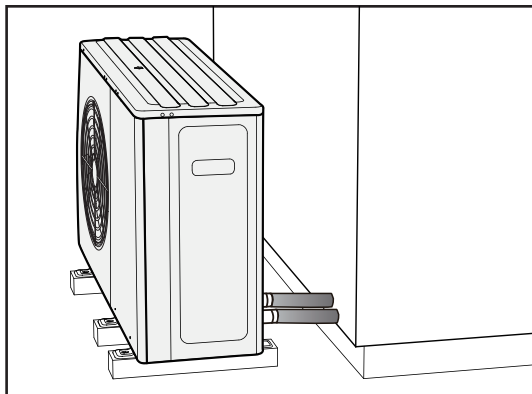

### NOTE

- The insulation material should be provided with a fire resistance rating of B1 or above and comply with all applicable regulations.
- The thermal conductivity of the sealing material should be below 0.039 W/mK.

Recommended thickness of the sealing material is shown as below.

Piping length (m) between the unit and the terminal device	Minimum insulation thickness(mm)
< 20	19
20~30	32
30~40	40
40~50	50

If the outdoor ambient temperature is higher than 30 °C and the humidity is higher than RH 80 %, the thickness of the sealing materials should be at least 20 mm to avoid condensation on the surface of the seal.

## 6.7 Freeze protection

### 6.7.1 Protected by software

The software is equipped with specific functions to protect the entire system from freezing by using the heat pump and the backup heater (if available).

- When the temperature of the water flow in the system drops to a certain value, the unit will heat the water using the heat pump, electric heating tape, or backup heater.
- The anti-freeze function is enabled only when the temperature increases to a certain value.

### CAUTION

- In the event of power failure, the above features would fail to protect the unit from freezing. Therefore, always keep the unit powered on.
- If the power supply for the unit is to be switched off for a long time, the water in the system pipe needs to be drained to avoid damage to the unit and pipeline system due to freezing.
- In case of power failure, add glycol to the water. Glycol lowers the freezing point of the water.

### 6.7.2 Protected by glycol

Glycol lowers the freezing point of water.

### CAUTION

Ethylene glycol and propylene glycol are toxic.

### CAUTION

Glycol can corrode the system. When uninhibited glycol comes into contact with oxygen, it becomes acidic. This corrosion process is accelerated by copper and high temperature. The acidic uninhibited glycol attacks metal surfaces, forming galvanic corrosion cells that can cause severe damage to the system. Therefore, it is important to follow these steps:

- Let a qualified specialist treat the water correctly;
- Select a glycol with corrosion inhibitors to counteract acids formed by the oxidation of glycols;
- Do not use any automotive glycol because its corrosion inhibitors have a limited lifetime and contain silicates which can contaminate or block the system;
- Do not use galvanized pipes in glycol systems as such pipes may lead to the precipitation of certain components in the glycol's corrosion inhibitor.

### NOTE

Glycol absorbs moisture from the environment, so it is important to avoid using glycol exposed to air. If glycol is left uncovered, the water content increases, lowering the glycol concentration and potentially causing hydraulic components to freeze. To prevent this, take precautions and minimize glycol's exposure to air.



## Types of glycol

The types of glycol that can be used depend on whether the system contains a domestic hot water tank:

If	Then
The system contains a domestic hot water tank	Only use propylene glycol (a)
The system does NOT contain a domestic hot water tank	Either propylene glycol(a) or ethylene glycol can be used

(a) Propylene glycol, including the necessary inhibitors, falls in Category III according to EN1717.

## Required concentration of glycol

The required concentration of glycol depends on the lowest expected outdoor temperature, and on whether you want to protect the system from bursting or from freezing. To prevent the system from freezing, more glycol is required.

Add glycol according to the table below.

Lowest expected outdoor temperature	Prevention from bursting (1)	Prevention from freezing (2)
-5 °C	10 %	15 %
-10 °C	15 %	25 %
-15 °C	20 %	35 %
-20 °C	25 %	N/A *
-25 °C	30 %	N/A *
-30 °C	35 %	N/A *

\* Additional action is needed to prevent freezing.

- (1) : Glycol can prevent the piping from bursting, but cannot prevent the liquid inside the piping from freezing.
- (2) : Glycol can prevent the liquid inside the piping from freezing.

### NOTE

- The required concentration might vary depending on the type of glycol used. ALWAYS compare the requirements from the table above with the specifications provided by the glycol manufacturer. If necessary, meet the requirements set by the glycol manufacturer.
  - The added concentration of glycol should NEVER exceed 35 %.
  - If the liquid in the system is frozen, the pump will NOT be able to start. Please note that solely preventing the system from bursting may not prevent the liquid inside from freezing.
    - If water remains stagnant within the system, it is highly likely to freeze and result in system damage.

## Glycol and the maximum allowed water volume

Adding glycol to the water loop reduces the maximum allowed water volume of the system.

## 6.7.3 About freeze protection valves (supplied by the user)

### NOTE

Do NOT install freeze protection valves, if glycol is added to the water. Otherwise, glycol may leak from the freeze protection valves.

When no glycol is added to the water, you can use freeze protection valves to drain the water from the system before it freezes.

- Install freeze protection valves (supplied by the user) at all lowest points of the field piping.
- Normally closed valves (located indoors near the piping entry/exit) can prevent drainage of water from indoor piping when the freeze protection valves are open.

## 6.7.4 Measure without freeze protection

In cold environments, if there is no antifreeze (e.g. glycol) in the system or lasting power failure or pump failure is foreseen, drain the system (as shown in the figure below).

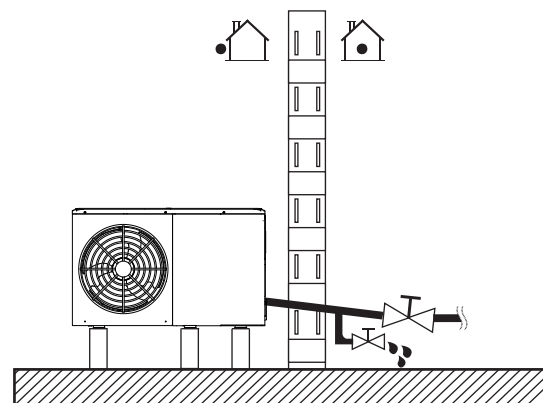

### NOTE

If water is not removed from the system in freezing weather when the unit is not in use, the frozen water may damage the water circle parts.

## 6.7.5 Freeze protection for water loop

All internal hydronic parts are insulated to reduce heat loss. The field piping must also be insulated. In the event of a power failure, the above features would not protect the unit from freezing.

The software contains special functions using the heat pump and backup heater (if optional and available) to protect the entire system from freezing. When the temperature of the water flow in the system drops to a certain value, the unit will heat the water, either using the heat pump, the electric heating tap, or the backup heater. The anti-freeze function will be disabled only when the temperature increases to a certain value.

Water may enter the flow switch and cannot be drained out, and may freeze when the temperature is low enough. The flow switch should be removed and dried before being installed in the unit.

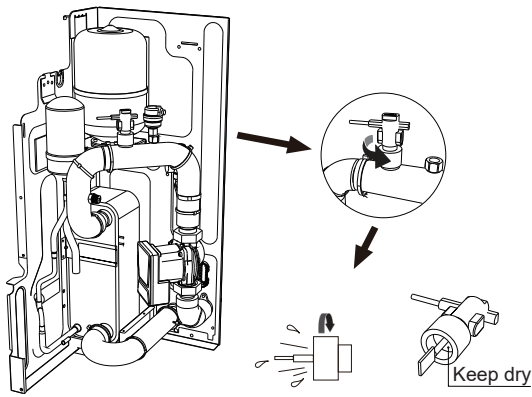

### NOTE

- Rotate the flow switch counterclockwise to remove it.
- Dry the flow switch completely.

## 6.8 Check of water loop

The conditions below should be met before installation:

- The maximum water pressure is lower than or equal to 3 bar.
- The maximum water temperature is lower than or equal to 75 °C according to safety device setting.
- Drain taps must be installed at lowest points of the system to ensure complete drainage of the circuit during maintenance.
- Air purge valves must be installed at highest points of the system. The vents should be located at points that are easily accessible for service. An automatic air purge valve is provided inside the unit. Verify that this air purge valve is not tightened so that automatic release of air from the water loop is possible.

## 7 ELECTRICAL INSTALLATION

### ⚠ DANGER

Risk of electrocution.

### 7.1 Opening the electrical box cover

To access the unit for installation and maintenance, follow the instructions below.

### ⚠ WARNING

Risk of electrocution.  
Risk of burning.

### NOTE

- Illustrations below are based on 8-16 kW units. The principle is the same for 4-6 kW units.
- Keep the screws properly for later use.

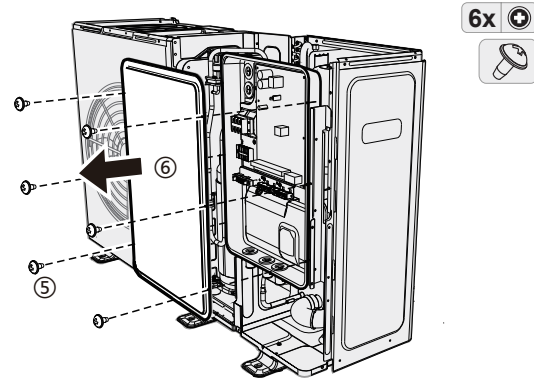
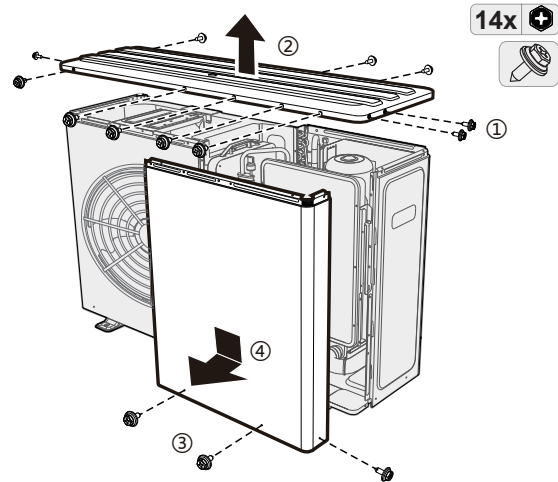

## 7.2 Precautions for electrical wiring

### ⚠ WARNING

- The appliance should be installed in accordance with national wiring regulations.
- Follow WIRING DIAGRAM for electrical wiring that is located on the rear side of the electrical box cover.
- This appliance incorporates an earth connection for functional purposes only.
- Be sure to install the required fuses or circuit breakers. An all-pole disconnection switch having a contact separation of at least 3 mm in all poles should be connected in fixed wiring.

### ⚠ WARNING

It is prohibited to install emergency stop switches, remote switches which for stopping the unit, including circuit breaker, contactor and relay, within 2 meters of the unit.

### ⚠ CAUTION

- A main switch or other means of disconnection, such as having a contact separation in all poles, must be incorporated in the fixed wiring in accordance with relevant local laws and regulations.
- Use only copper wires.
- Never squeeze bundled cables and keep them away from piping and sharp edges.

- Make sure no external pressure is applied to the terminal connections.
- The field wiring must be carried out in accordance with the wiring diagram supplied with the unit and the instructions given below.
  - Be sure to use a dedicated power source, instead of a power source shared by another appliance. Earth the unit properly, including the wired controller. Do not connect the unit to a utility pipe, surge protector, or telephone earth. Incomplete earthing may cause electrocution.
  - An earth fault circuit interrupter (30 mA) must be installed to avoid electrical shock. Use 3-core shielded wires.
  - Be sure to install the required fuses or circuit breakers.
  - A leakage protection switch must be installed to the power supply of the unit.
  - Attach an earth fault circuit interrupter and fuse to the power supply line.

## Power cable and communication cable

### NOTE

- Communication wires must be shielded, including the unit-to-controller ABXYE line.
- Use H07RN-F as the power cable. Only the thermistor and wired controller wiring are provided with low voltage.
- Power cables and communication wires must be laid out separately, and cannot be placed in the same conduit. Otherwise, electromagnetic interference may occur.
  - Secure the electrical wires with cable ties so that they will not come in contact with the piping, particularly on the high-pressure side.
    - The unit is equipped with an inverter. A phase advancing capacitor will reduce the power factor improvement effect, and may cause abnormal heating of the capacitor due to high-frequency waves. Installing a phase advancing capacitor is not permitted.
    - The external load current should be lower than 0.2 A. If the single load current is higher than 0.2 A, the load must be controlled through an AC contactor.
    - "AHS1" and "AHS2" terminal ports only provide on/off signals.
    - The expansion valve E-heating tape, plate heat exchanger E-heating tape, and flow switch E-heating tape share the same terminal port.

## Earthing

### NOTE

- The equipment must be earthed.
- Any high-voltage external load, if it is metal or an earthed port, must be earthed.
- Make sure the earth fault circuit interrupter is compatible with the inverter (resistant to high frequency electrical noise) to avoid unnecessary startup of the interrupter.

### 7.3 Overview of electrical wiring

The illustration below gives an overview of the required field wiring among different parts.

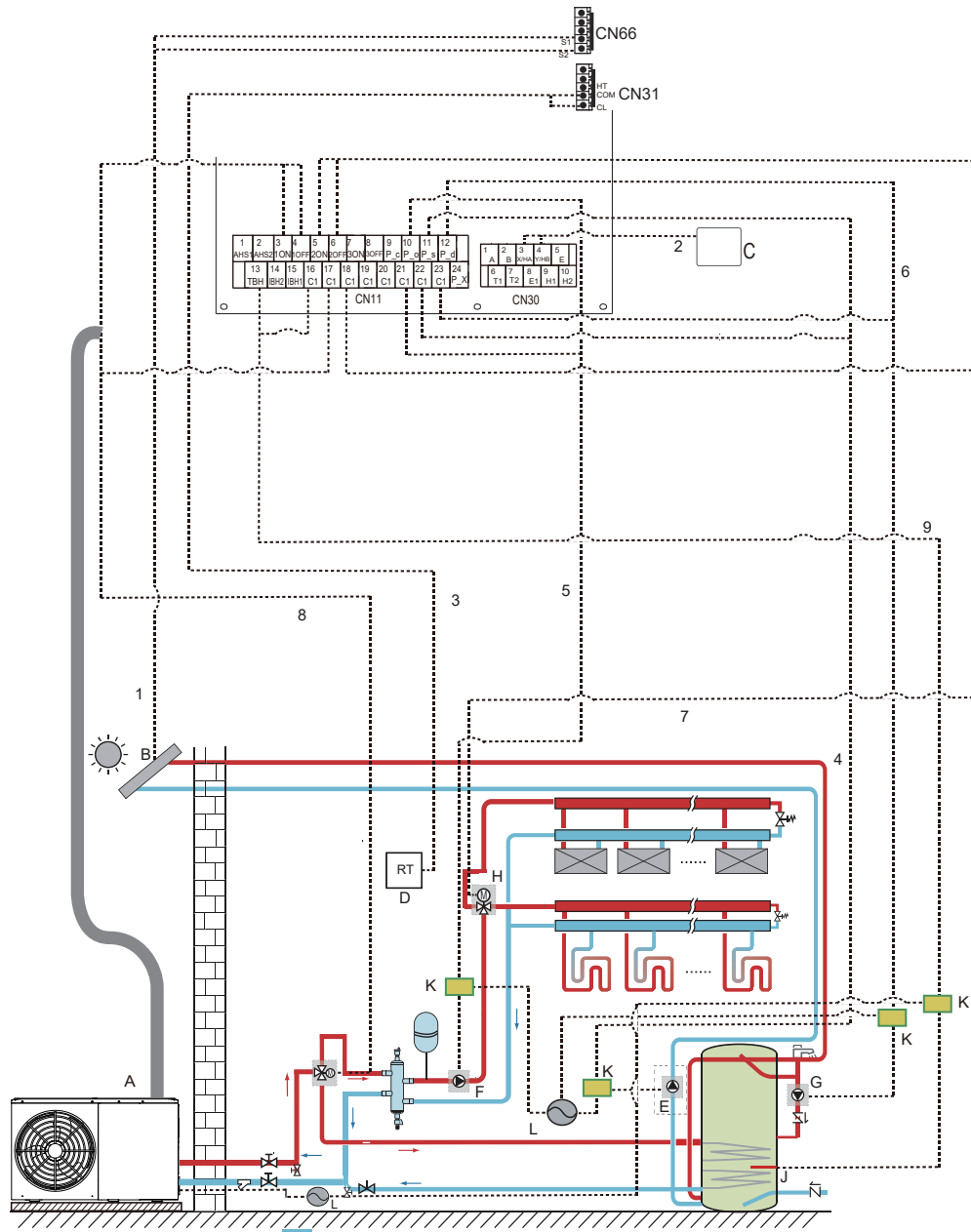

Code	Assembly unit	Code	Assembly unit
A	Main unit	G	P_d:DHW pump(field supply)
B	Solar energy kit(field supply)	H	SV2:3-way valve(field supply)
C	Wired Controller	I	SV1:3-way valve for domestic hot water tank(field supply)
D	<b>Low</b> voltage room thermostat(field supply)	J	Booster heater
E	P_s:Solar pump(field supply)	K	Contactor
F	P_o:Outside circulation pump(field supply)	L	Power supply

Item	Description	AC/DC	Required number of conductors	Maximum running current
1	Solar energy kit signal cable	AC	2	200 mA
2	Wired Controller cable	AC	2	200 mA
3	Room thermostat cable	AC	2	200 mA(a)
4	Solar pump control cable	AC	2	200 mA(a)
5	Outside circulation pump control cable	AC	2	200 mA(a)
6	DHW pump control cable	AC	2	200 mA(a)
7	SV2: 3-way valve control cable	AC	3	200 mA(a)
8	SV1: 3-way valve control cable	AC	3	200 mA(a)
9	Booster heater control cable	AC	2	200 mA(a)

(a) Minimum cable section AWG18 (0.75 mm<sup>2</sup>).

(b)The thermistor cable are delivered with the unit: if the current of the load is large, an AC contactor is needed.

## 7.4 Electrical wiring guidelines

### 7.4.1 Field wiring guidelines

- Most field wiring of the unit is to be made on the terminal block inside the switch box. To gain access to the terminal block, remove the switch box service panel.
- Fix all cables with cable ties.
- The backup heater requires a dedicated power circuit.
- Installations equipped with a domestic hot water tank (supplied by the user) require a dedicated power circuit for the booster heater.
- Please refer to the Installation & Owner's Manual of the domestic hot water tank. Secure the wiring in the order shown below.
- Lay out the electrical wires so that the front cover does not rise up during the wiring, and attach the front cover securely.
- Install the wires and fix the cover firmly so that the cover may be fit properly.

### 7.4.2 Operating current and wire diameter

- 1) Select the wire diameter ( minimum value) individually for each unit based on Table 7-1 and Table 7-2. The rated current in Table 7-1 means MCA in Table 7-2. In case the MCA exceeds 63 A, the wire diameters should be selected according to the local wiring regulation.
- 2) The maximum allowable voltage deviation between phases is 2 %.
- 3) Select circuit breakers that have a contact separation of at least 3 mm in all poles for full disconnection. MFA is used to select the current circuit breakers and residual current operation breakers.
- 4) The inverter PCB is equipped with an overcurrent protector (fuse). In case any additional overcurrent protector is needed, refer to the TOCA in Table 7-2.

### NOTE

- (a) Minimum cable section AWG18 (0.75 mm<sup>2</sup>).
- (b) The thermistor cable is delivered with the unit.

Table 7-1

Rated current (A)	Nominal cross-sectional area (mm <sup>2</sup> )	
	Flexible cord	Cable for fixed wiring
≤ 3	0.5 and 0.75	1 and 2.5
> 3 and ≤ 6	0.75 and 1	1 and 2.5
> 6 and ≤ 10	1 and 1.5	1 and 2.5
> 10 and ≤ 16	1.5 and 2.5	1.5 and 4
> 16 and ≤ 25	2.5 and 4	2.5 and 6
> 25 and ≤ 32	4 and 6	4 and 10
> 32 and ≤ 50	6 and 10	6 and 16
> 50 and ≤ 63	10 and 16	10 and 25

Table 7-2

1-phase 4-16 kW and 3-phase 12-16 kW

System	Outdoor unit				Power current			Compressor		OFM	
	Voltage (V)	Hz	Min. (V)	Max. (V)	MCA (A)	TOCA (A)	MFA (A)	MSC (A)	RLA (A)	KW	FLA (A)
4 kW	220-240	50	198	264	12	15	16	-	10	0.08	0.32
6 kW	220-240	50	198	264	13.5	15	16	-	10	0.08	0.32
8 kW	220-240	50	198	264	16	19	20	-	13	0.17	0.80
10 kW	220-240	50	198	264	17.5	19	20	-	13	0.17	0.80
12 kW	220-240	50	198	264	25	31	32	-	18	0.2	0.80
14 kW	220-240	50	198	264	26.5	31	32	-	18	0.2	0.80
16 kW	220-240	50	198	264	28	31	32	-	18	0.2	1.30
12 kW 3-PH	380-415	50	342	456	8.5	11	16	-	18	0.2	0.57
14 kW 3-PH	380-415	50	342	456	9	11	16	-	18	0.2	0.57
16 kW 3-PH	380-415	50	342	456	9.5	11	16	-	18	0.2	1.25

Backup heater

System	Outdoor Unit				Power Current		
	Voltage (V)	Hz	Min. (V)	Max. (V)	MCA (A)	TOCA (A)	MFA (A)
3 kW 1-PH	220-240	50	198	264	13.5	13.5	20
3 kW 3-PH	380-415	50	342	456	4.5	4.5	20
6 kW 3-PH	380-415	50	342	456	9	9	20
9 kW 3-PH	380-415	50	342	456	13.5	13.5	20

MCA: min. circuit current. (A)

TOCA: total over current (A)

MFA: max. fuse current (A)

MSC: max. starting current. (A)

RLA: rated load amps (A); the rated input current of the compressor at the maximum frequency (max hz) when the unit is running in cooling or heating mode

KW : rated motor output

FLA : full-load current (A)

### 7.4.3 Tightening torque

Item	Tightening torque (N•m)
M 4 (power terminal, electric control board terminal)	1.2-1.5
M 4 (earthing)	1.2-1.5

### NOTE

Over-tightening might damage the screws.

Tighten the screws with a proper screwdriver. Using an improper screwdriver could damage the screws and provide improper tightening torques.

## 7.4.4 Back plate layout for wiring

### 4-6 kW

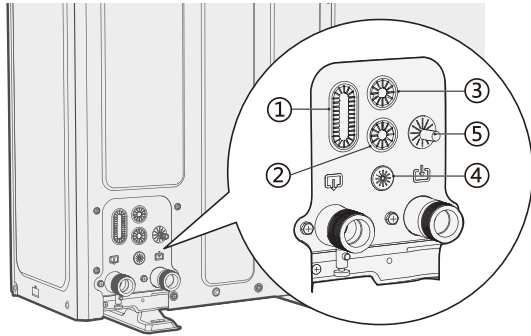

### 8-16 kW

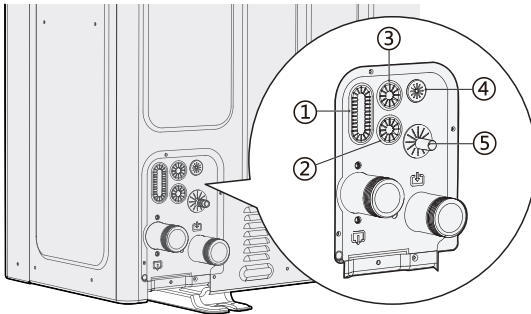

①②③	For high voltage wiring.
④	For low voltage wiring.
⑤	Safety valve drain.

## 7.5 Connection with power supply

### 7.5.1 Precautions

For connection of the unit to a power supply terminal, the terminal should be a circular wiring terminal with an insulation casing (see Figure 7.1).

If it is impossible to use such a circular wiring terminal, observe the following instructions:

- Use a power cord that conforms to the specifications and connect the power cord firmly. Apply a proper tightening torque shown in the above section (Tightening torques) to prevent the cord from being accidentally pulled out by an external force.
- Do not connect two power cords with different diameters to the same power supply terminal. Otherwise, the wires may overheat due to loose wiring (See Figure 7.2).

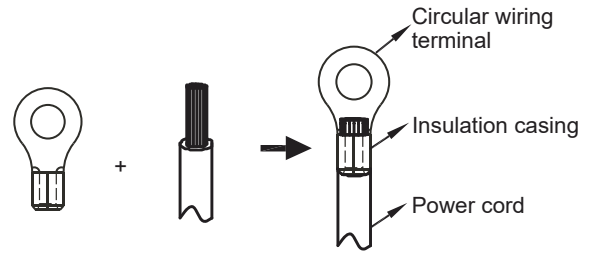
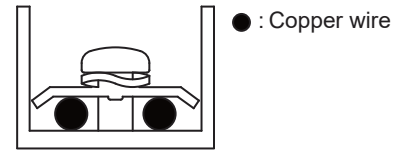

Figure 7.1



Proper power wiring connections

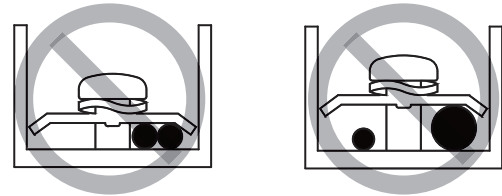

Figure 7.2

### 7.5.2 Wiring of main power supply

#### ⚠ CAUTION

- Use a round crimp-style terminal for connection to the power supply terminal board.
- The power cord model is H07RN-F.
- Illustrations below are for 3-phase units. The principle is the same for 1-phase units.
- Illustrations below are for units with a backup heater.

1 phase without backup heater.

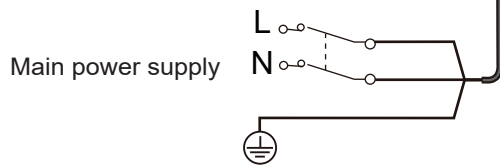
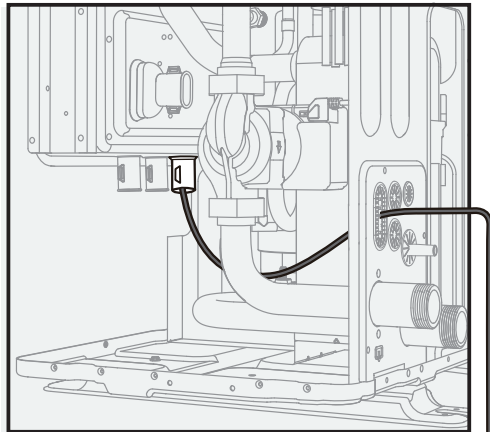
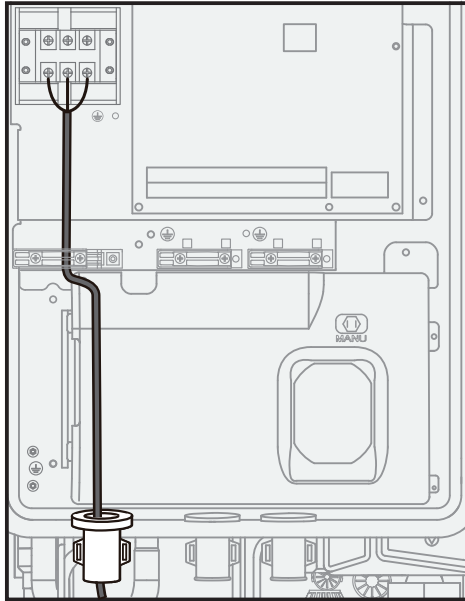

**⚠ CAUTION**

Leakage protection switch must be installed.

3 phase without backup heater.

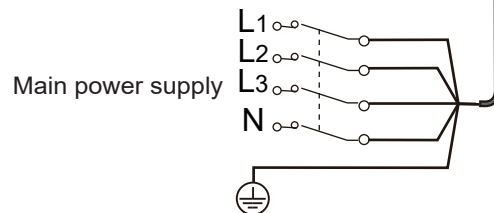
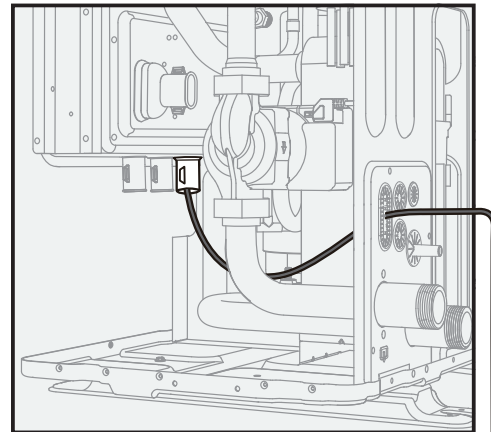
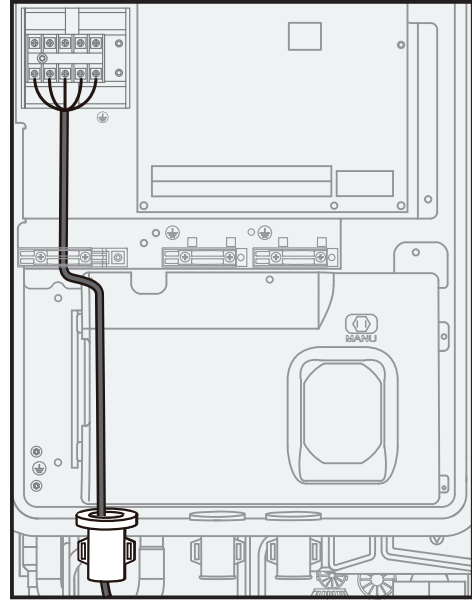

**⚠ CAUTION**

Leakage protection switch must be installed.



1 phase with backup heater.

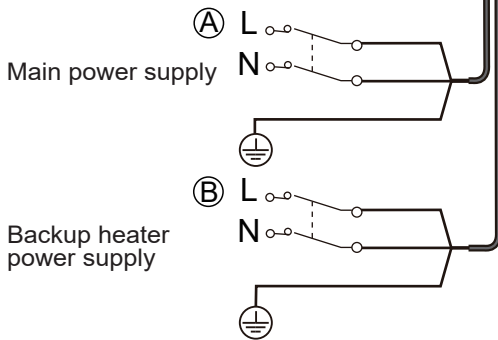
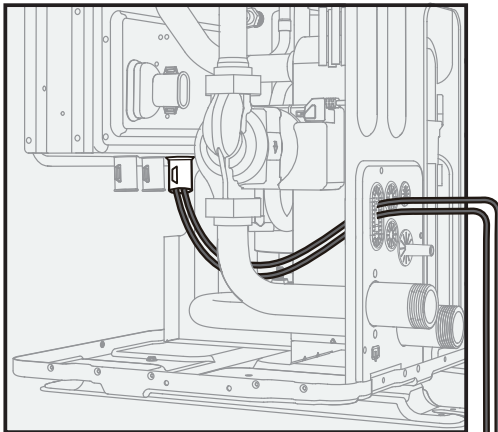
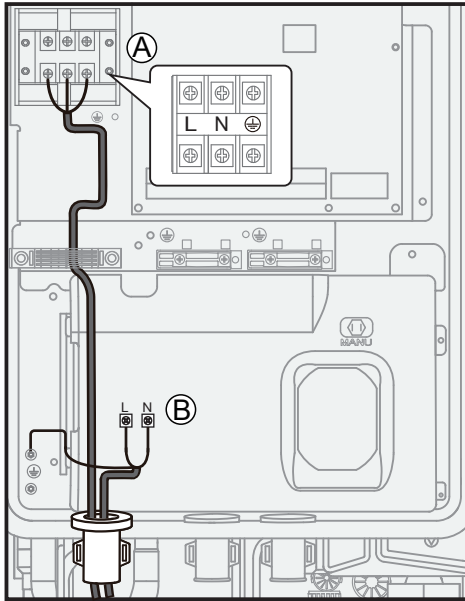

**⚠ CAUTION**  
Leakage protection switch must be installed.

3 phase with backup heater.

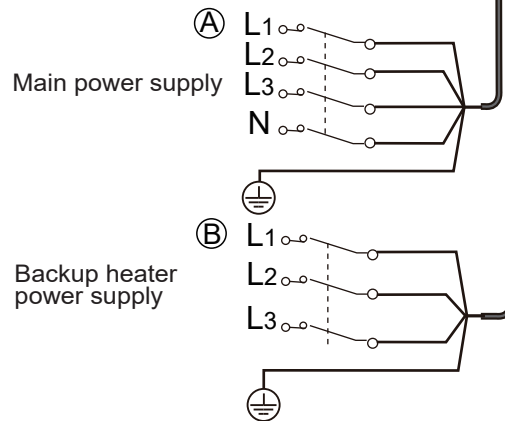
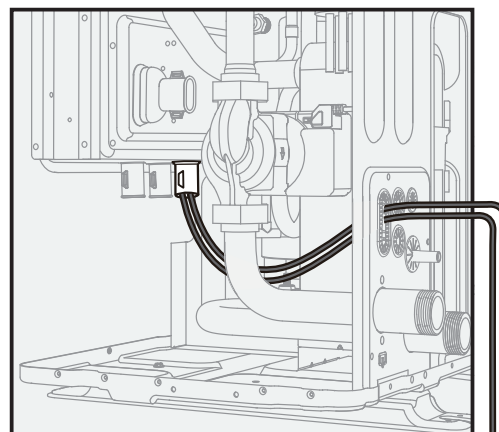
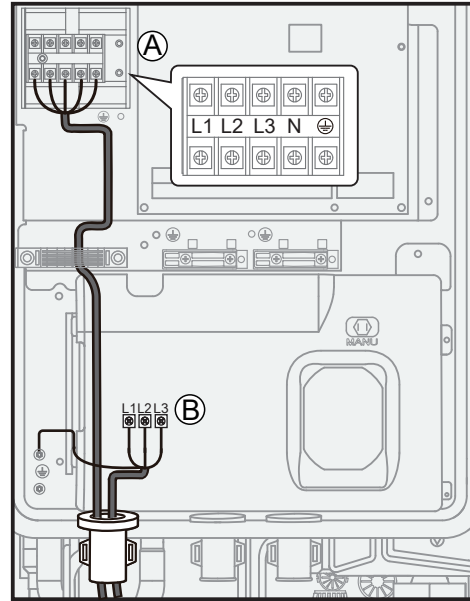

**⚠ CAUTION**  
Leakage protection switch must be installed.

### 7.5.3 Wiring of backup heater power supply (optional)

Refer to the illustration above for the wiring.

#### ⚠ CAUTION

- To ensure the unit is fully earthed, always connect the backup heater power supply and the earth cable.
- This appliance which connect 1-phase 3 kW backup heater can be connected only to a supply with system impedance no more than  $0.465 \Omega$ . In case necessary, please consult your supply authority for system impedance information.

### 7.6 Connection of other components

The port provides the control signal to the load. Two kinds of control signal ports:

- Type 1: dry contactor without voltage.
- Type 2: the port provides the signal with 220-240 V~ 50 Hz voltage.

#### 💡 NOTE

- If the current of load is lower than 0.2 A, the load can be connected to the port directly. If the load current is higher than or equal to 0.2 A, it is necessary to connect the AC contactor to the load.
- Illustrations below are for 3-phase units. The principle is the same for 1 -phase units.
- Illustrations below are based on units with a backup heater.

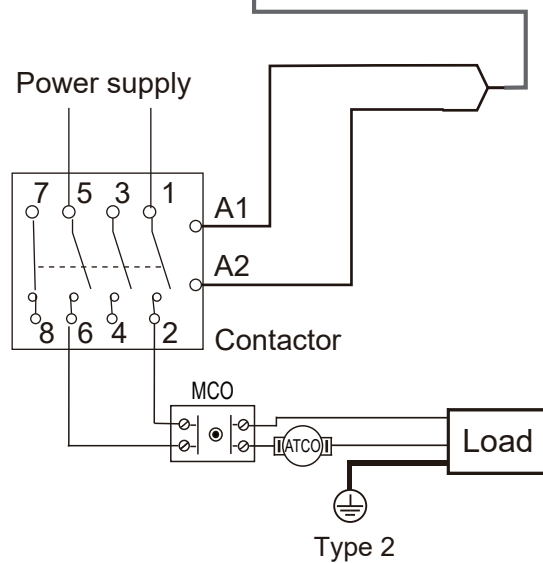
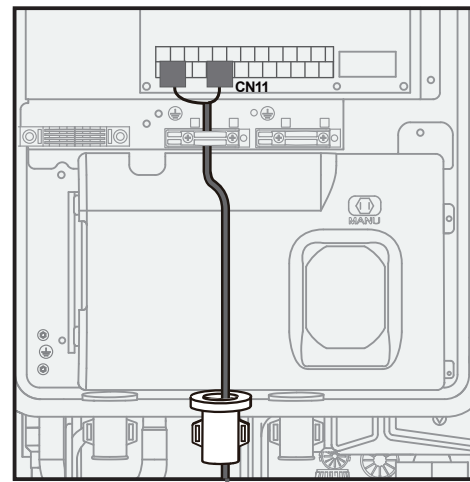
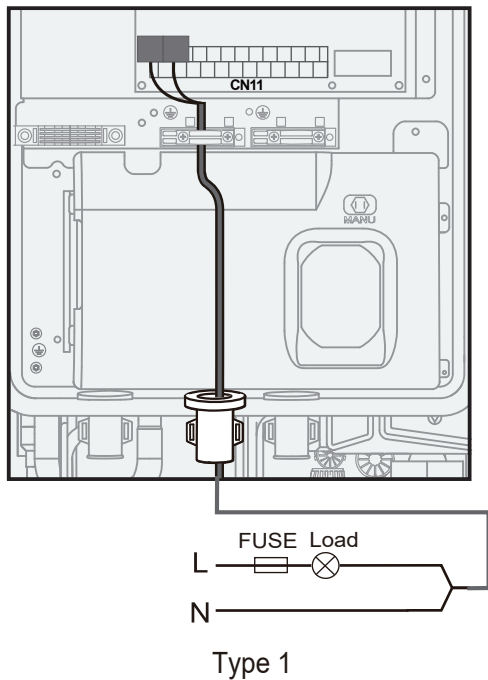

Control signal port of hydraulic module: The CN11 contains terminals for the 3-way valve, pump, booster, and heater, etc.

Connect the cable to an appropriate terminal as shown in the figure and fix the cable reliably.

### 7.6.1 Wiring of additional heat source control (AHS)

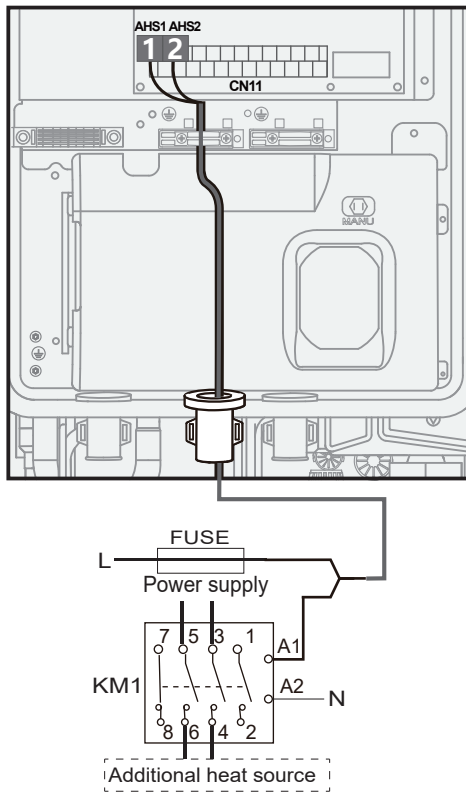

The wiring between the switch box and the back plate is shown in 7.5.2 Wiring of main power supply.

L-N Voltage	220-240 V AC
Maximum running current (A)	0.2
Minimum wire size (mm <sup>2</sup> )	0.75
Control port signal type	Type 1

#### NOTE

This part only applies to basic units (without a backup heater). For customized units (with a backup heater), the hydraulic module should not be connected to any additional heat source as there is an interval backup heater in the unit.

### 7.6.2 Wiring of 3-way valves SV1, SV2 and SV3

#### NOTE

Refer to the 3.9 Typical applications for the installation locations of SV1, SV2 and SV3.

Only for the type shown as below.

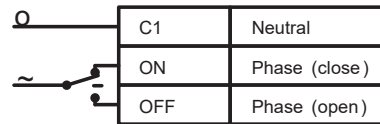

SV1:

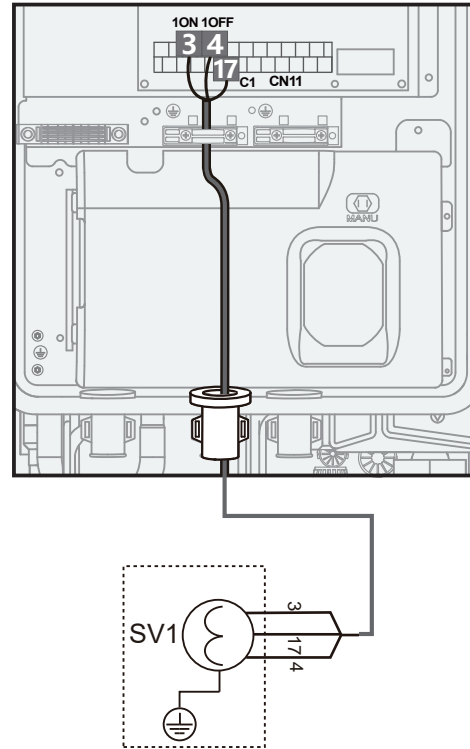

SV2:

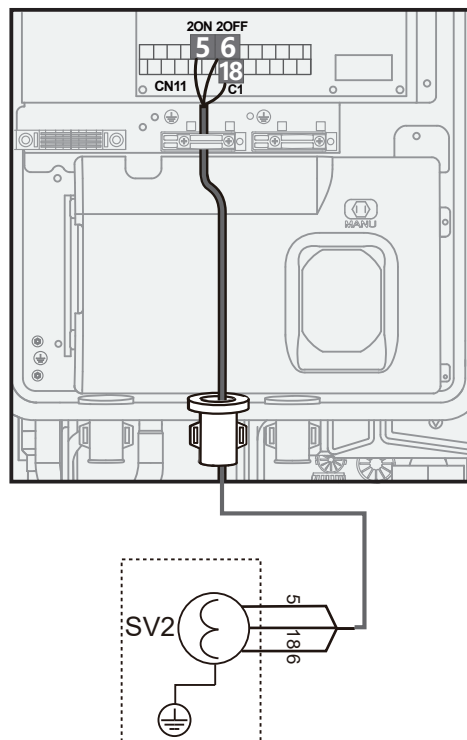

SV3:

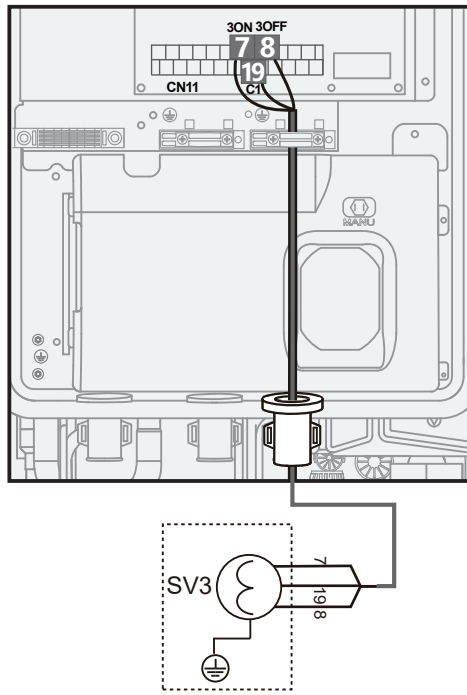

Voltage	220-240 V AC
Maximum running current (A)	0.2
Minimum wire size (mm <sup>2</sup> )	0.75
Control port signal type	Type 2

**NOTE**

C1 is for the neutral conductor .

7.6.3 Wiring of additional pumps

Zone 2 pump P<sub>c</sub>:

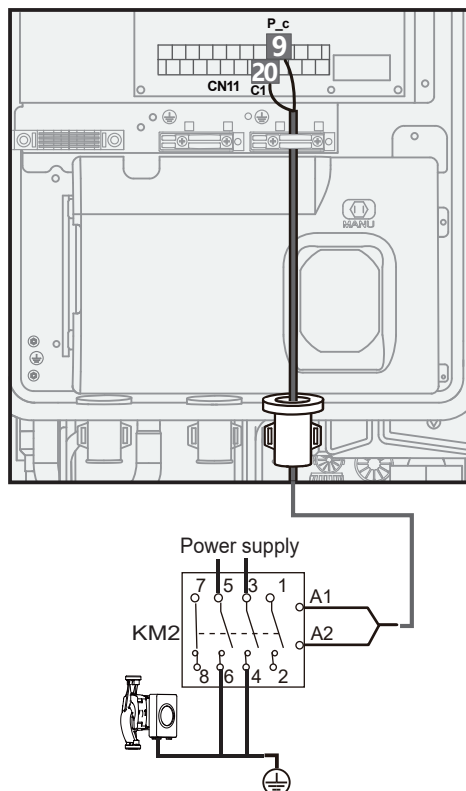

Additional circulation pump P<sub>o</sub>:

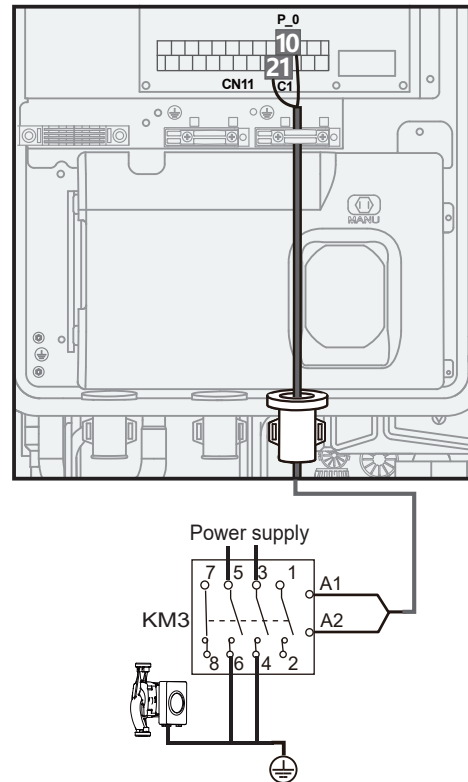

Solar energy pump P<sub>s</sub>:

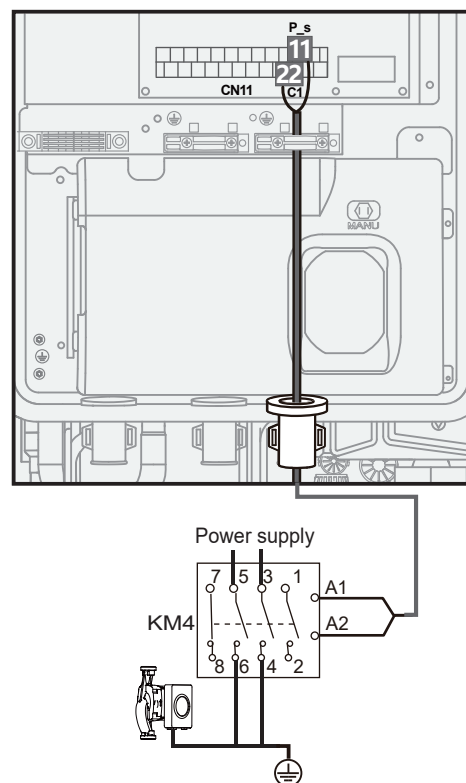

### DHW pump P\_d:

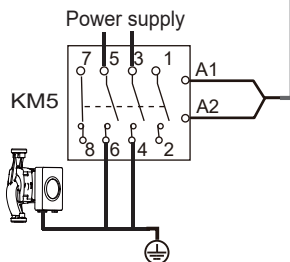
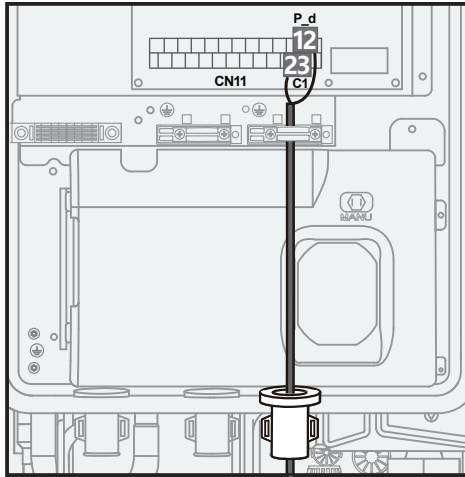

Voltage	220-240 V AC
Maximum running current (A)	0.2
Minimum wire size (mm <sup>2</sup> )	0.75
Control port signal type	Type 2

### 7.6.4 Wiring of alarm or defrost run (P\_x)

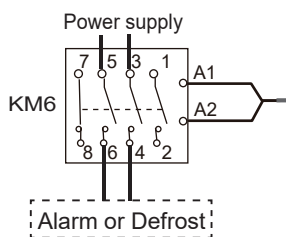
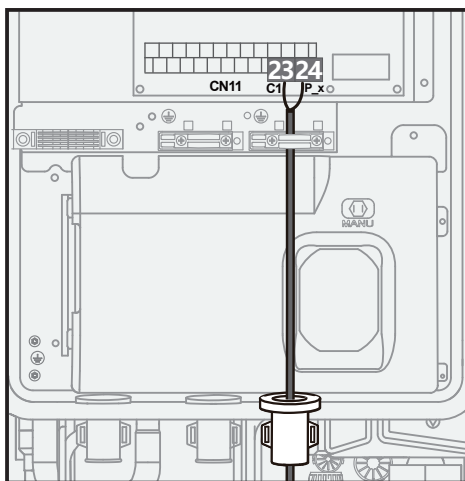

Voltage	220-240 V AC
Maximum running current (A)	0.2
Minimum wire size (mm <sup>2</sup> )	0.75
Control port signal type	Type 2

### 7.6.5 Wiring of tank booster heater (TBH)

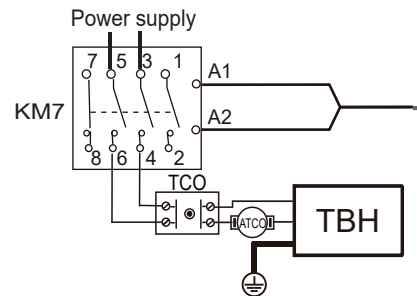
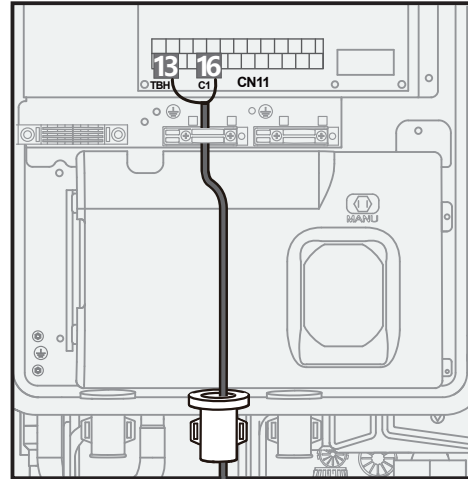

### NOTE

TCO: Manual reset thermal protector  
ATCO: Auto reset thermal protector

### 7.6.6 Wiring of external IBH box

#### NOTE

see installation manual of external IBH box.  
If the DIP switch corresponding to the backup heater is set to INTERNAL (refer to the Wiring Diagram), C3 or C4 fault would appear after backup heater running.

For one-step control IBH:

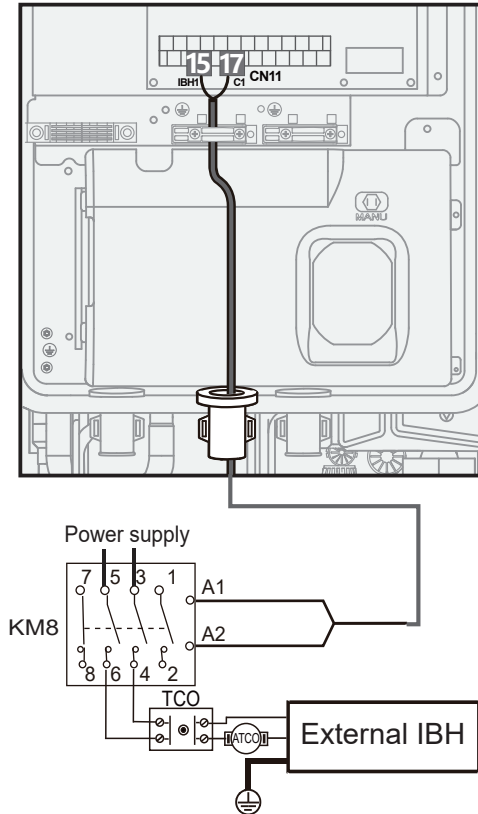

For two/three - step control IBH:

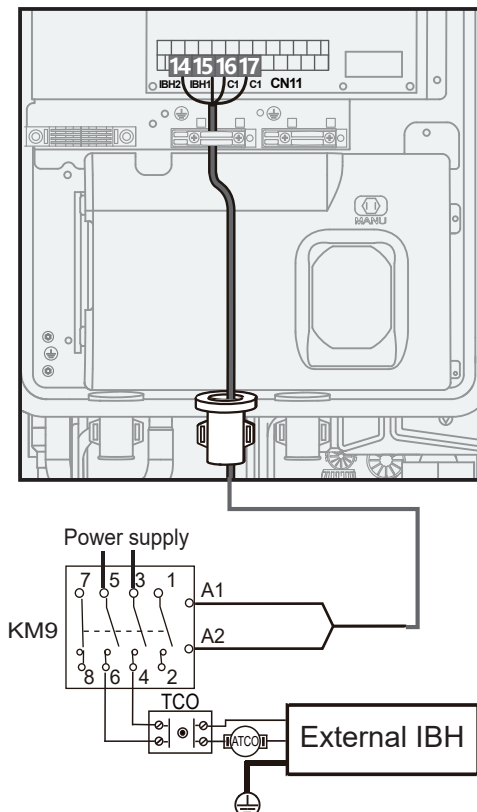

Voltage	220-240 V AC
Maximum running current (A)	0.2
Minimum wire size (mm <sup>2</sup> )	0.75
Control port signal type	Type 2

#### NOTE

- The unit only sends an ON/OFF signal to the heater.
- IBH2 cannot be wired independently.

### 7.6.7 Wiring of room thermostat (RT)

Room thermostat (low voltage): "Power supply" provides the voltage to the RT.

#### NOTE

The room thermostat must be low-voltage.

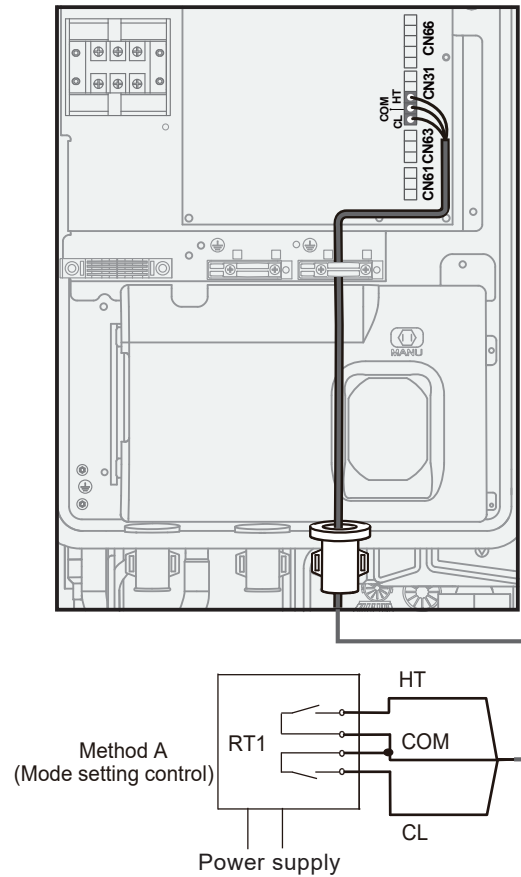

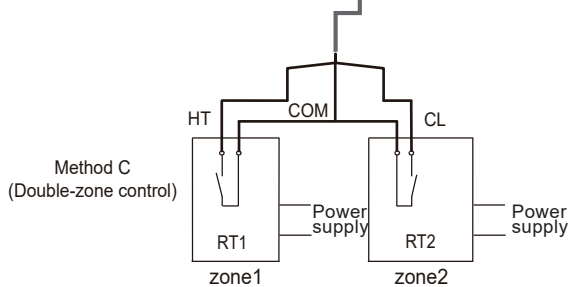
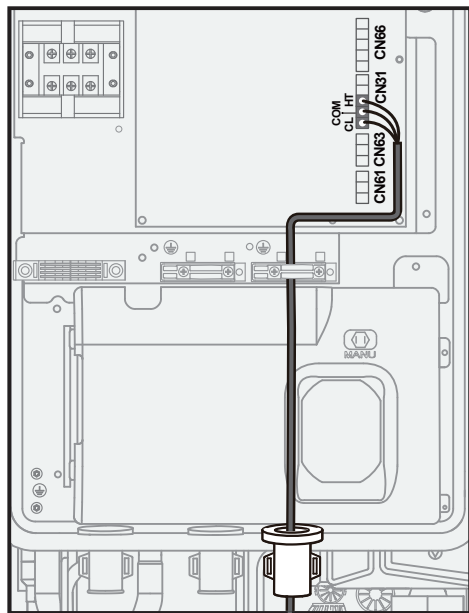
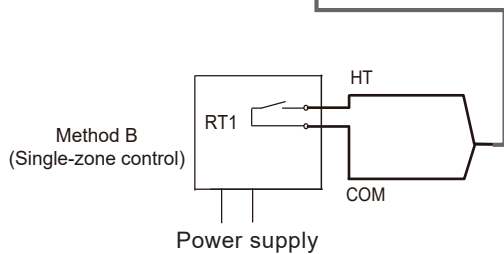
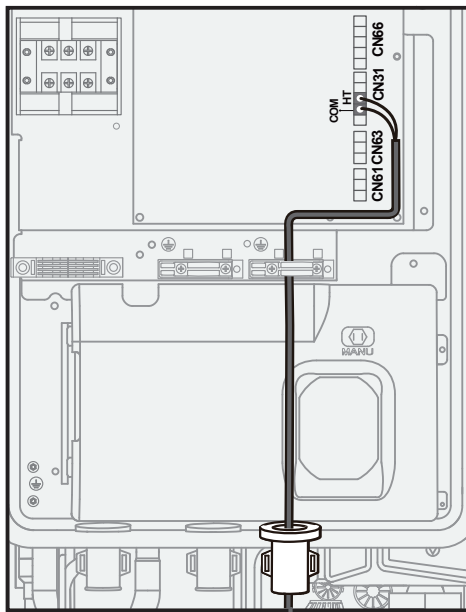

The thermostat cable can be connected in three ways (as described in the figures above) and the specific connection method depends on the application.

#### Method A (Mode set control)

RT can control heating and cooling individually. When the hydraulic module is connected with the external temperature controller, ROOM THERMOSTAT is set to MODE SET on the user interface:

A.1 When "CL" of the thermostat keeps closing for 15 s, the system will run according to the priority mode set on the user interface. The default priority mode is Heating.

A.2 When "CL" of the thermostat keeps opening for 15 s and "HT" close, the system will run according to the non-priority mode set on the user interface.

A.3 When "HT" of the thermostat keeps opening for 15 s and "CL" open, the system will turn off. (Mode set control)

A.4 When "CL" of the thermostat keeps opening for 15 s and "HT" open, the system will turn off.

The port closing voltage is 12 V DC, the port disconnection voltage is 0 V DC.

#### Method B (single-zone control)

RT provides the switch signal to the unit. ROOM THERMOSTAT is set to ONE ZONE on the user interface:

B.1 When "HT" of the thermostat keeps closing for 15 s, unit turns on.

B.2 When "HT" of the thermostat keeps opening for 15 s, unit turns off.

#### Method C (double-zone control)

The hydraulic module is connected with two room thermostats, and ROOM THERMOSTAT is set to DOUBLE ZONE on the user interface:

C.1 When "HT" of the thermostat keeps closing for 15 s, zone1 turn on. When "HT" of the thermostat keeps opening for 15 s, zone1 turn off.

C.2 When "CL" of the thermostat keeps closing for 15 s, zone2 turn on. When "CL" of the thermostat keeps opening for 15 s, zone2 turn off.

### NOTE

- The wiring of the thermostat should correspond to the settings of the wired controller. Refer to 9.2 Configuration.
- Power supply of the device and room thermostat must be connected to the same neutral line.
- When ROOM THERMOSTAT is not set to NON, the indoor temperature sensor Ta cannot be set to VALID.
- Zone 2 can only operate in heating mode. When cooling mode is set on the wired controller and zone 1 is OFF, "CL" in Zone 2 closes, and system still remains 'OFF'. For installation, the wiring of thermostats for Zone 1 and Zone 2 must be correct.

### 7.6.8 Wiring of solar energy input signal (low voltage)

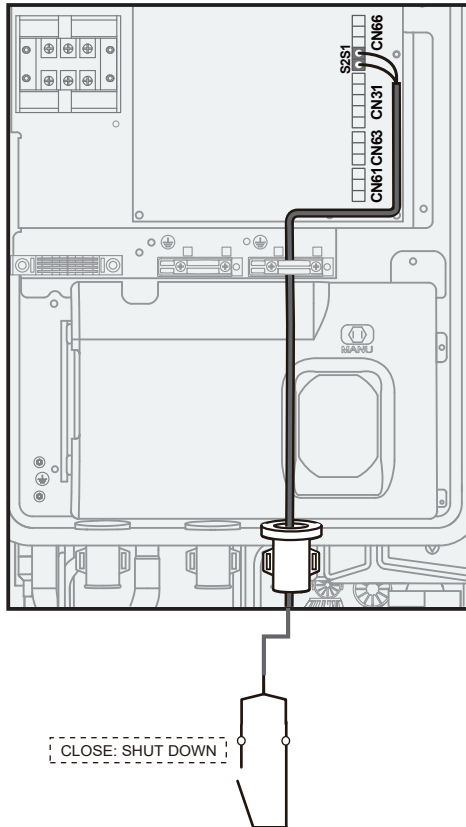

### 7.6.9 Wiring of remote shutdown

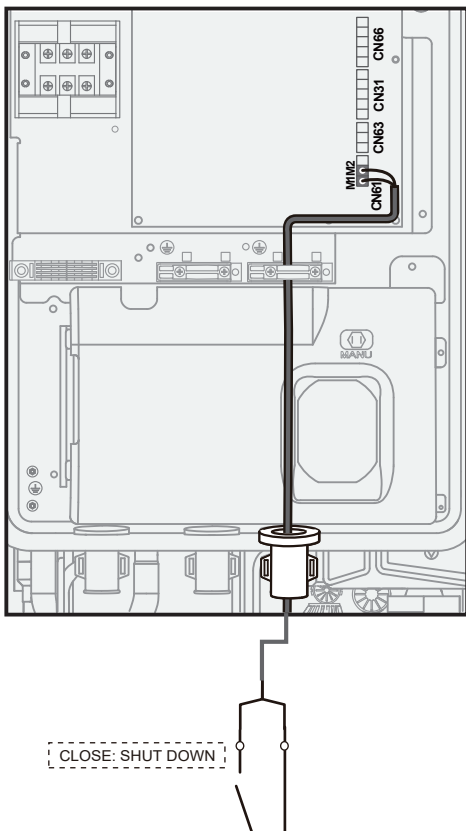

### 7.6.10 Wiring of smart grid

The unit has a smart grid feature, and there are two ports on the PCB to connect SG signals and EVU signals as below:

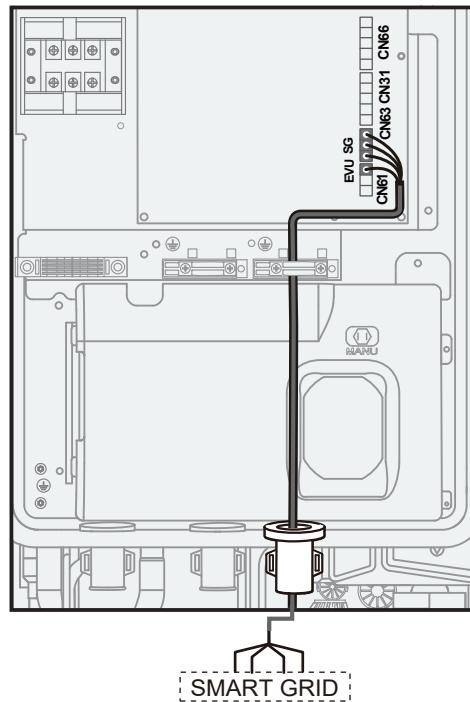

#### **NOTE**

To utilize smart grid function, the DHW mode must be set available.

#### 1) SG = ON, EVU = ON.

- The heat pump will operate in DHW mode firstly.
- When TBH is set available, if T5 is lower than 69 °C, the TBH will be turned on forcibly (The heat pump and TBH can operate at the same time.); if T5 is higher than or equal to 70 °C, the TBH will be turned off. (DHW: Domestic Hot Water; T5S is the set temperature of the water tank.)

- When TBH is set unavailable and IBH is set available for DHW mode, if T5 is lower than 69 °C, the IBH will be turned on forcibly (The heat pump and IBH can operate at the same time.); if T5 is higher than or equal to 70 °C, the IBH will be turned off.

#### 2) SG = OFF, EVU = ON.

- The heat pump will operate in DHW mode firstly.
- When TBH is set available and DHW mode is set ON, if T5 is lower than T5S-2, the TBH will be turned on (The heat pump and TBH can operate at the same time.); If T5 is higher than or equal to T5S + 3, the TBH will be turned off.

- When TBH is set unavailable and IBH is set available for DHW mode, if T5 is lower than T5S-dT5\_ON, the IBH will be turned on (The heat pump and IBH can operate at the same time.); If T5 is higher than or equal to Min (T5S + 3, 70), the IBH will be turned off.

#### 3) SG = OFF, EVU = OFF.

The unit will operate properly.

#### 4) SG = ON, EVU = OFF.

The heat pump, IBH, and TBH will be turned off immediately.



## 7.7 Cascade Function

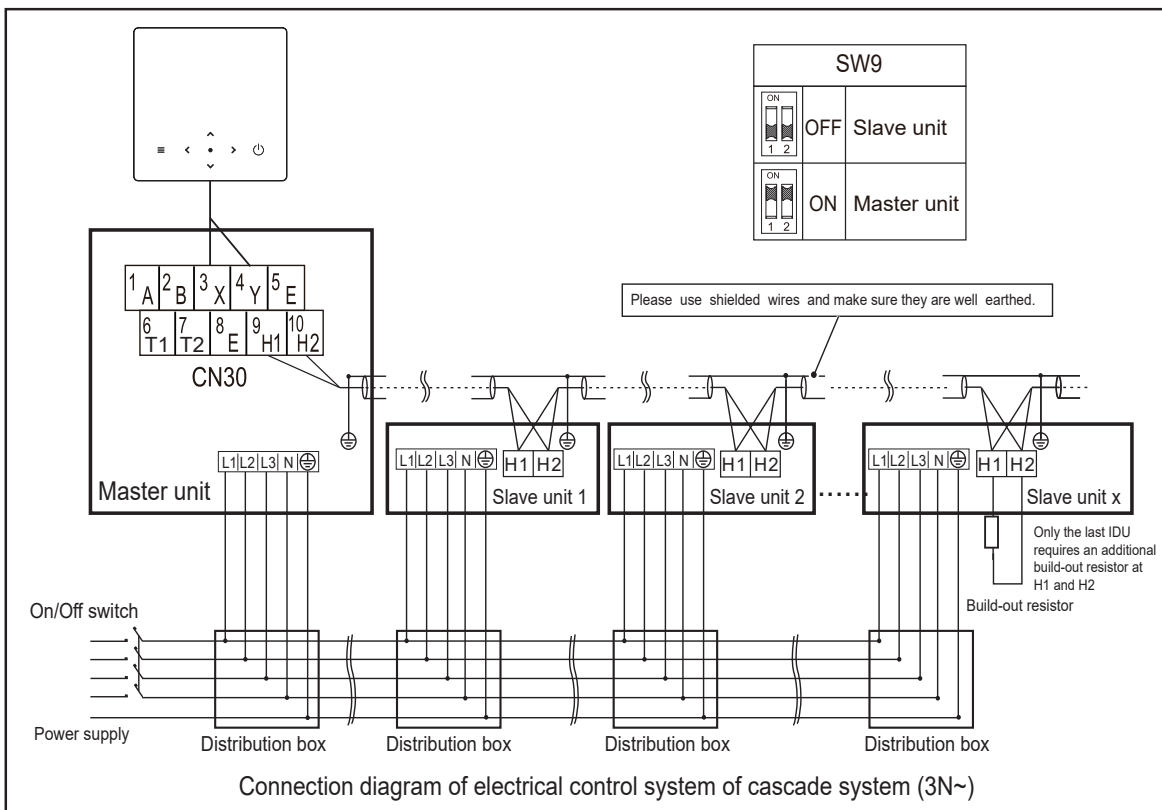
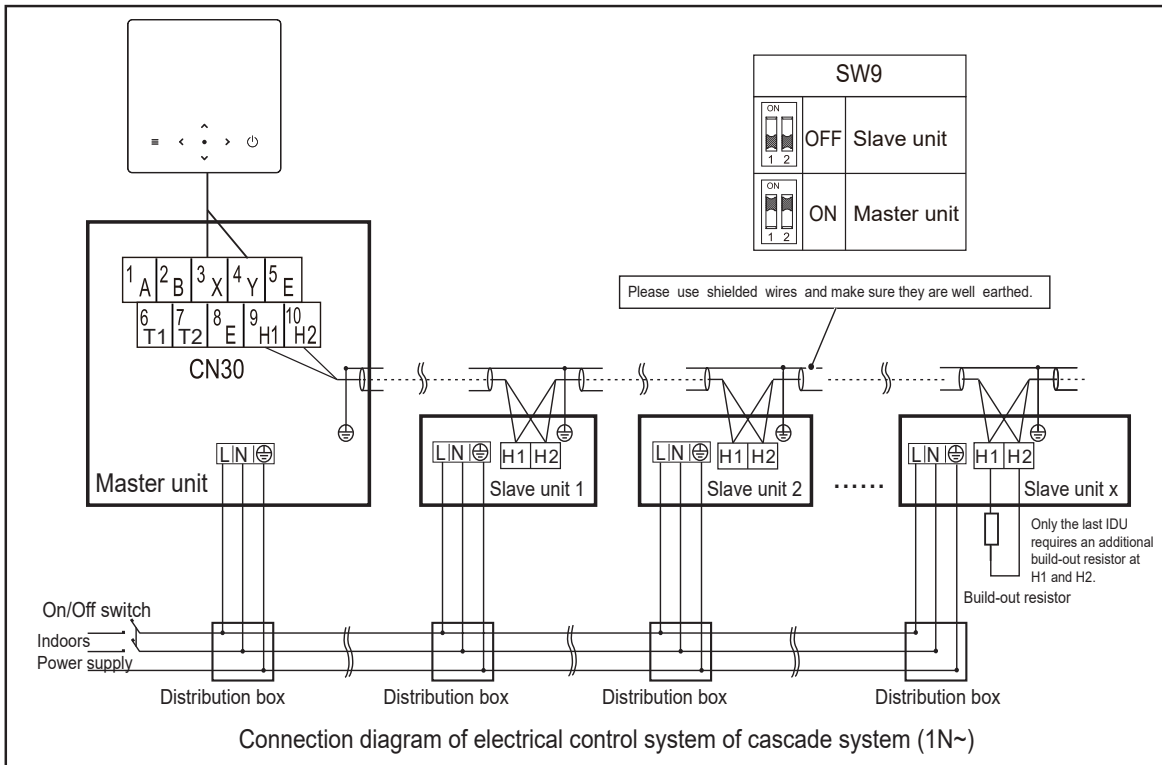

### ⚠ CAUTION

1. The cascade function of the system supports up to 6 units.
2. To ensure successful automatic addressing, all units must be connected to the same power supply and powered on uniformly.
3. Only the master unit can connect with the controller, and the SW9 of the master unit must be switched to "on". Slave units cannot connect with the controller.
4. Please use shielded wires and make sure they are well earthed.

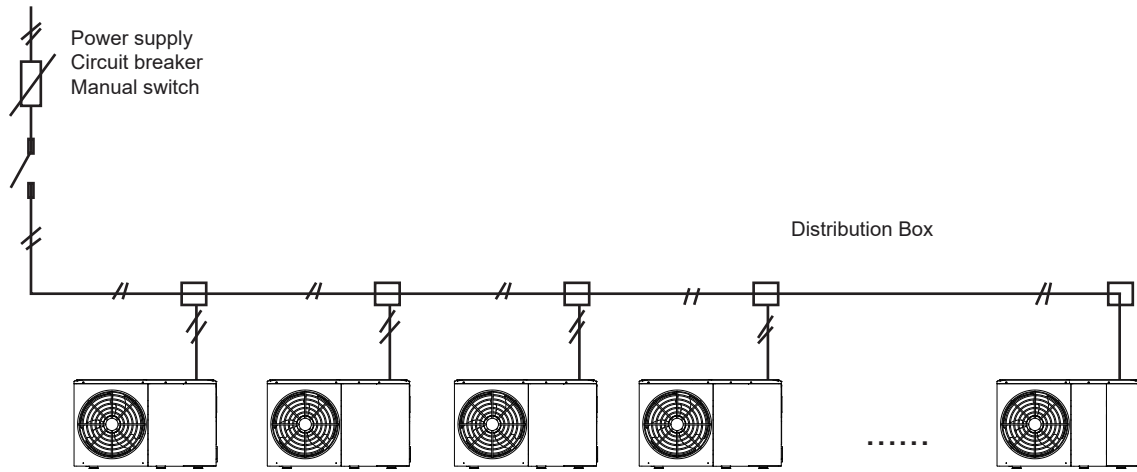

## 7.8 Connection for Other Optional Components

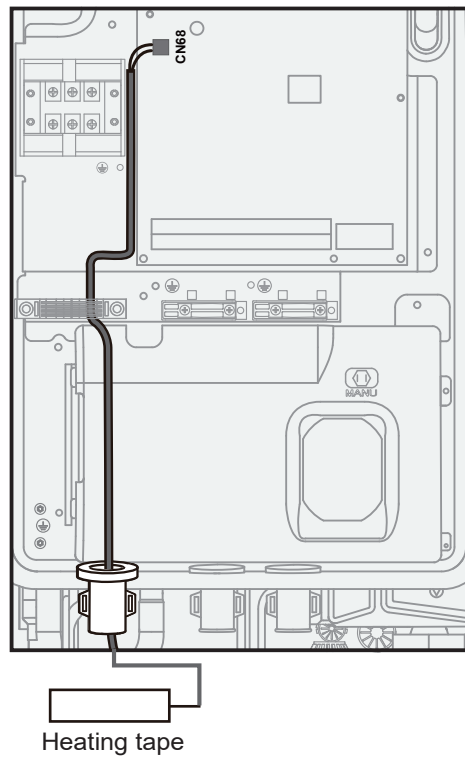

### 7.8.1 Wiring of drainage pipe heating tape



For the drainage pipe heating tape, the power shall not exceed 40 W. Working current is up to 200 mA, supply voltage 230 VAC.

#### NOTE

##### Use tie wraps

To prevent refrigerant or insects from entering into the electrical control box and causing fire, after wiring, the sleeve  should be fastened with a tie wrap (accessory) 

## 8 INSTALLATION OF WIRED CONTROLLER

### ⚠ CAUTION

- The general instructions on wiring in previous chapters should be observed.
- The wired controller must be installed indoors and kept away from direct sunlight.
- Keep the wired controller away from any ignition source, flammable gas, oil, water vapor, and sulfide gas.
- To avoid electromagnetic disturbance, keep the wired controller at a proper distance from electric appliances, such as lamps.
- The circuit of the remote wired controller is a low-voltage circuit. Never connect it with a standard 220-240 V~/380-415 V~ circuit or place it into a same wiring tube with the circuit.
- Use a terminal connection block to extend the signal wire if necessary.
- Do not use a megger to check insulation of the signal wire upon completion of connection.

### 8.1 Materials for installation

Verify that the accessory bag contains the following items:

No.	Name	Qty.	Remarks
1	Wired controller	1	_____
2	Wood screw ST 4 × 20	4	For mounting on a wall
3	Plastic support bar	2	For mounting on an 86-type box
4	Philips head screw, M 4 × 25	2	For mounting on an 86-type box
5	Wall plugs	4	For mounting on a wall
6	Bottom cap of the wired controller	1	_____

### 8.2 Dimensions

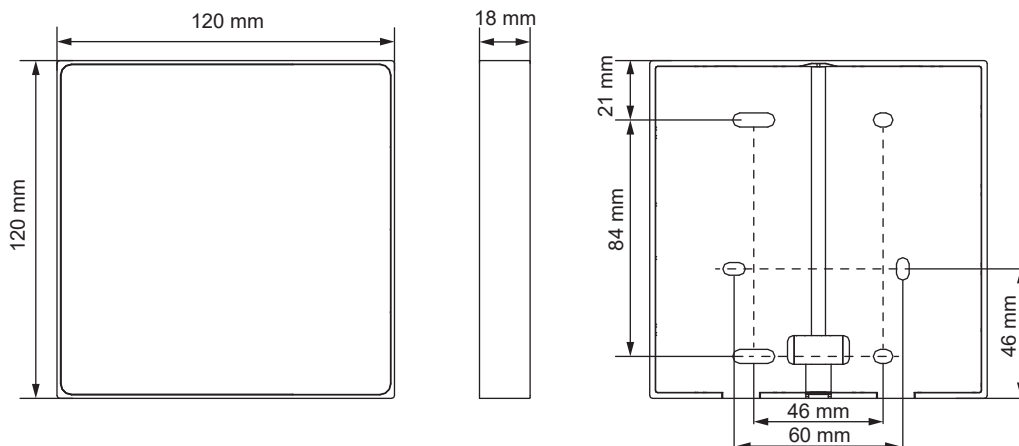

### 8.3 Wiring

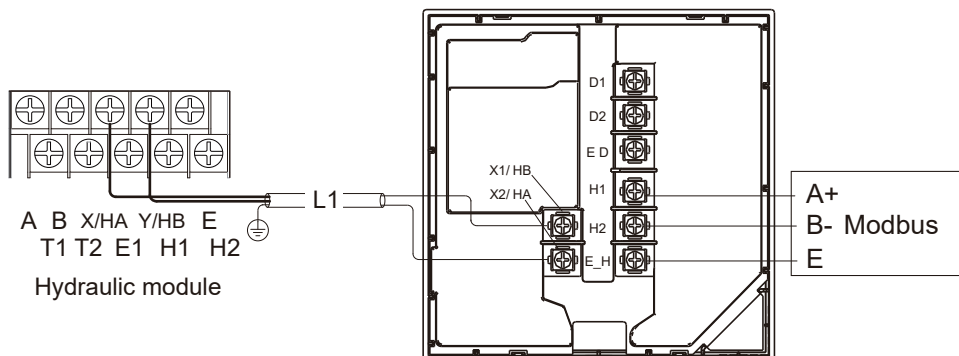

Input voltage (HA/HB)	18 V DC
Wire size	0.75 mm <sup>2</sup>
Wire type	2-core shielded twisted pair cable
Wire length	L1 ≤ 50 m

The maximum length of the communication wire between the unit and the controller is 50 m.

## Route

Bottom-side wiring out

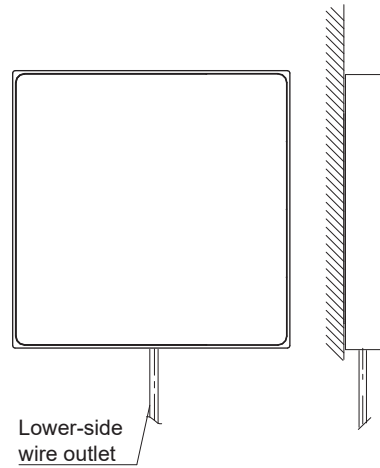
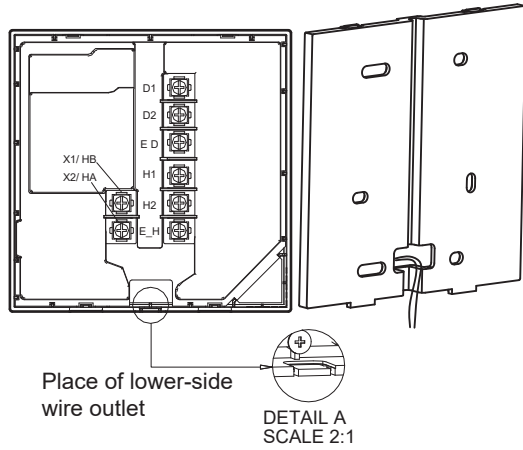

Inside wall wiring (with an 86-type box)

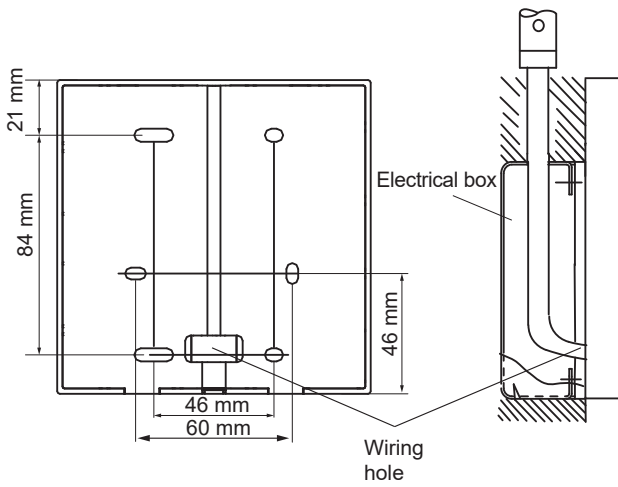

Inside wall wiring (without an 86-type box)

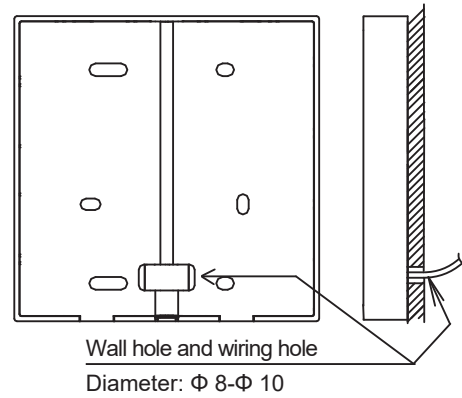

## 8.4 Mounting

### NOTE

Only wall-mount the wired controller, instead of embedded, otherwise maintenance will not be possible.

### Mounting on a wall (without an 86-type box)

Directly install the back cover on the wall with four ST4 x 20 screws.

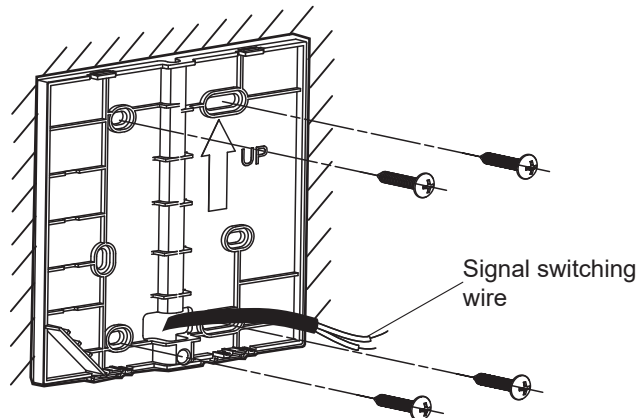

### Mounting on a wall (with an 86-type box)

Install the back cover on an 86-type box with two M 4 x 25 screws, and fixing the box on the wall with two ST 4 x 20 screws. If the box is not embedded in the wall completely, you could save two ST 4 x 20 screws depending on the situation.

- Adjust the length of the plastic bolt in the accessory box to make it suitable for installation.
- Fix the wired controller's bottom cover to the wall through the screw bar by using cross head screws. Make sure the bottom cover is set flush on the wall.

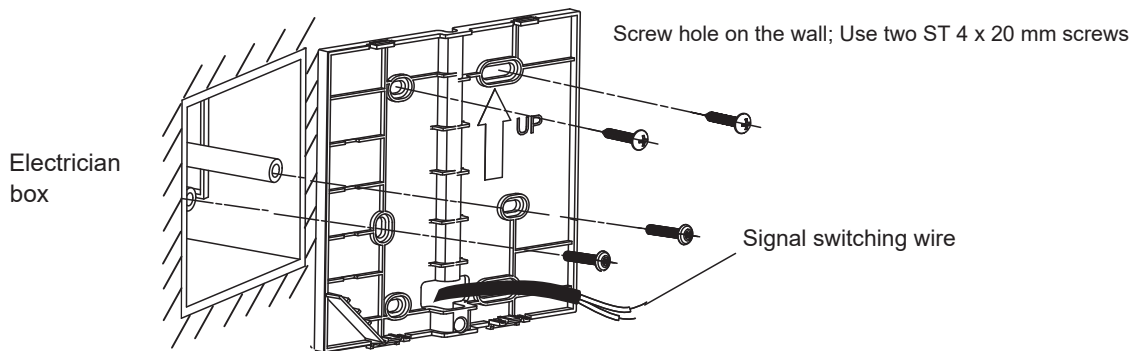

Screw hole on 86 electrical box; Use two M 4 x 25 mm screws

- Buckle the front cover, and fit the front cover to the back cover properly, leaving the wire unclamped during the installation.

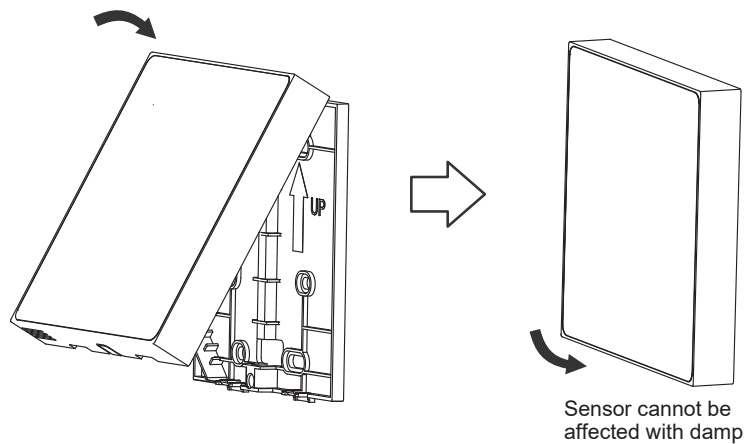

### NOTE

To prevent water from entering the remote wired controller, use traps and plugs to seal the wire connections during wiring.

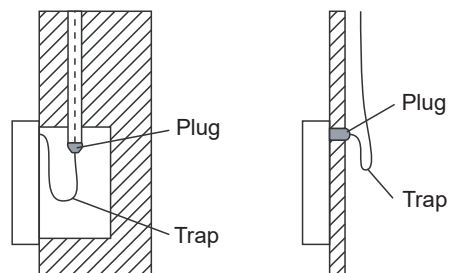

Avoid the water enter into the wired remote controller, use trap and putty to seal the connectors of wires during wiring installation.

### NOTE

Over-tightening the screw can cause deformation of the back cover.

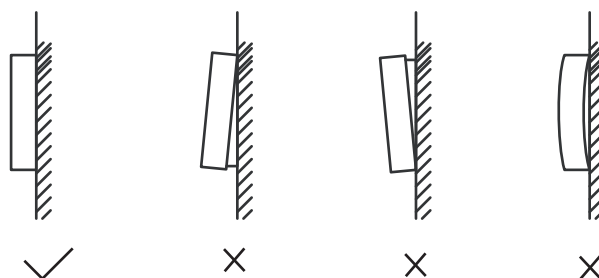

## 9 COMPLETION OF INSTALLATION

### **⚠ DANGER**

Risk of electrocution.  
Risk of burning.

### **💡 NOTE**

The illustrations below are for 8-16 kW units. The principle is the same for 4-6 kW units.

Tightening torque

4.1 N•m

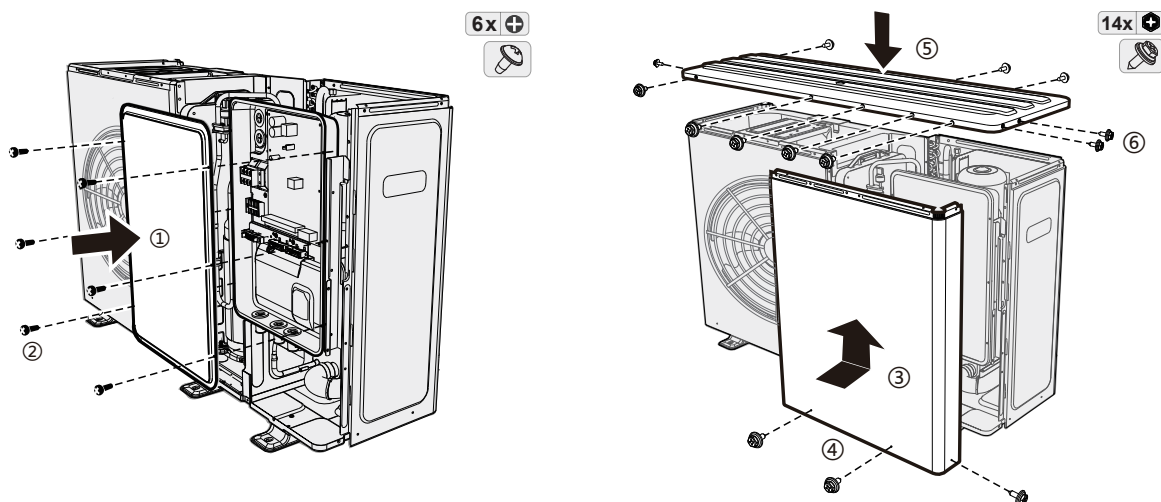

## 10 CONFIGURATION

The unit should be configured by an authorized installer to match the installation environment (outdoor climate, installed options, etc.) and meet the user demand.

Follow the instructions below for the next step.

### 10.1 Check before configuration

Before powering on the unit, check the following items:

<input type="checkbox"/>	<b>Field wiring:</b> make sure all wiring connections observe the instructions mentioned in the 7. Electrical installation
<input type="checkbox"/>	<b>Fuses, circuit breakers, or protection devices:</b> check the size and type according to the instructions mentioned in the 7.4 Electrical wiring guidelines. Make sure that no fuses or protection devices have been bypassed.
<input type="checkbox"/>	<b>Backup heater's circuit breaker:</b> ensure the backup heater's circuit breaker in the switch box is closed (It varies with the backup heater type). Refer to the wiring diagram.
<input type="checkbox"/>	<b>Booster heater's circuit breaker:</b> ensure the booster heater's circuit breaker is closed (applicable only to units with an optional domestic hot water tank).
<input type="checkbox"/>	<b>Internal wiring:</b> check the wiring and connections inside the switch box for loose or damaged parts, including earth wiring.
<input type="checkbox"/>	<b>Mounting:</b> check and ensure that the unit and the water loop system are properly mounted to avoid water leakage, abnormal noises and vibrations during the unit startup.
<input type="checkbox"/>	<b>Damaged equipment:</b> check the components and piping inside the unit for any damage or deformation.
<input type="checkbox"/>	<b>Refrigerant leak:</b> check the inside of the unit for any refrigerant leakage. In case of refrigerant leakage, follow the relevant content in the "Safety Precautions".
<input type="checkbox"/>	<b>Power supply voltage:</b> check the voltage of the power supply. The voltage must be consistent with the voltage on the identification label of the unit.
<input type="checkbox"/>	<b>Air vent valve:</b> make sure the air vent valve is open (at least 2 turns).
<input type="checkbox"/>	<b>Shut-off valve:</b> make sure that the shut-off valve is fully open.
<input type="checkbox"/>	<b>Sheet metal:</b> make sure all the sheet metal of the unit is mounted properly.
<input type="checkbox"/>	<b>Water volume:</b> make sure the water volume in the system is within the limitation.
<input type="checkbox"/>	<b>Strainer:</b> make sure the strainer is mounted properly and clean.

After powering on the unit, check the following items:

<input type="checkbox"/>	<p><b>Upon power-on of the unit, nothing is displayed on the wired controller:</b>            Check the following abnormalities before diagnosing possible error codes.            - Wiring connection issue (power supply or communication signal).            - Fuse failure on PCB.</p>
<input type="checkbox"/>	<p><b>Error code "E8" or "E0" is displayed on the wired controller:</b>            - Residual air exists in the system.            - The water level in the system is insufficient.            Before starting test run, make sure that the water system and the tank are filled with water, and air is removed. Otherwise, the pump or backup heater (optional) may be damaged.</p>
<input type="checkbox"/>	<p><b>Error code "E2" is displayed on the wired controller:</b>            - Check the wiring between the wired controller and the unit.</p>
<input type="checkbox"/>	<p><b>Initial start-up at low outdoor ambient temperature:</b>            To start the initial start-up in low outdoor ambient temperature, the water has to be heated gradually. Please use the preheating for floor function. (Refer to "SPECIAL FUNCTION" in FOR SERVICEMAN mode)</p>

**NOTE**

For underfloor heating application, floor could be damaged if the temperature rises sharply in a short time.  
 Please ask the building construction contractor for further information.



About error code, see "13.3 Error codes".

## 10.2 Configuration

To initialize the unit, a group of advanced settings should be provided by the installer. The advanced settings are accessible in FOR SERVICEMAN mode.

The overall parameters list of the advanced settings can be found in Annex B. Operation Settings.

### How to enter FOR SERVICEMAN mode

Press and hold  and  simultaneously for 3 seconds to enter the authorization page. Enter password 234 and confirm it. Then, the system jumps into the page with a list of advanced settings.

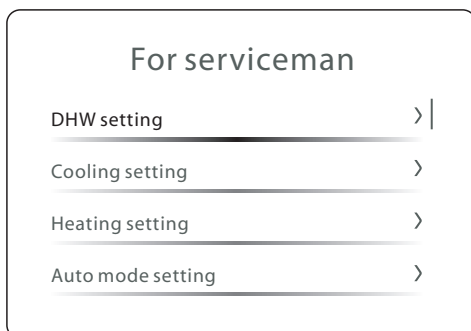
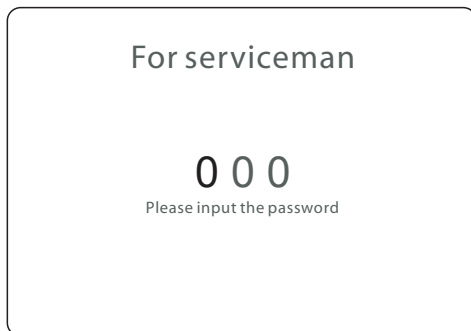

### NOTE

"FOR SERVICEMAN" is only for installer or other specialist with sufficient knowledge and skills.

The end user who use "FOR SERVICEMAN" is regarded as improper use.

### Save the settings and quit FOR SERVICEMAN mode

After all settings are adjusted, press , and the confirmation page pops out. Select Yes and confirm to quit FOR SERVICEMAN mode.

### NOTE

- The settings are saved automatically after you quit FOR SERVICEMAN mode.
- Temperature values displayed on the wired controller are measured in °C.

### 10.2.1 DHW setting

Select the target item and enter the setting page. Adjust the launch settings and values based on end user demands.

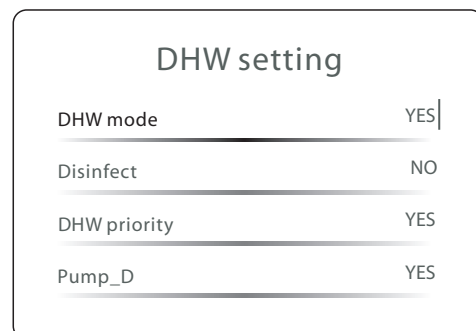

All set parameters and limitations can be found in 10.3 Set Operating Parameters.

## 10.2.2 Cooling setting

Cooling setting	
Cool mode	YES
t_T4_FRESH_C	0.5 hours
T4CMAX	52°C
T4CMIN	10°C

Refer to 10.2.1 DHW setting for the operation method.

## 10.2.3 Heating setting

Heating setting	
Heating mode	YES
t_T4_FRESH_H	0.5hours
T4HMAX	25°C
T4HMIN	-15°C

Refer to 10.2.1 DHW setting for the operation method. Either cooling mode or heating mode must be enabled, and they cannot be both set to NO at the same time.

## 10.2.4 Auto mode setting

Auto mode setting	
T4AUTOCMIN	25°C
T4AUTOHMAX	17°C

Refer to 10.2.1 DHW setting for the operation method.

## 10.2.5 Temp. type setting

Temp. type setting	
Water flow temp.	YES
Room temp.	NO
Double zone	YES

Refer to 10.2.1 DHW setting for the operation method. When both DOUBLE ZONE and ROOM TEMP. are enabled, the room temperature control is valid only for Zone 2, and Zone 1 is always under water temperature control.

When Room temp. is enabled, the temperature curve for the room temperature control zone is enforced, and the set temperature of the room temperature control zone can still be adjusted. The type of the temperature curve and the temperature offset can be set. (The unit will stop running if either the set temperature or the temperature curver is reached).

## 10.2.6 Room thermostat setting

Room thermostat setting	
Room thermostat	YES

Refer to 10.2.1 DHW setting for the operation method.

- When Room thermostat is set to any value rather than NO, the setting of Temp. type is invalid.
- When Room thermostat is set to DOUBLE ZONE, DOUBLE ZONE is enabled automatically, and the temperature control mode is water temperature control.
- When Room thermostat is set to MODE SETTING/ONE ZONE, DOUBLE ZONE is disabled automatically, and the temperature control mode is water temperature control.

1) When Room thermostat is set to NO, the room thermostat is invalid.

2) When Room thermostat is set to MODE SETTING, 10.2.6.2 Mode setting priority is visible. The wired controller cannot be used to turn on/off the unit or set the operation mode. Besides the timer related to DHW, all timers in Schedule are invalid. The unit can read the operating status of the unit, and set the temperature if the temperature curve is inactive.

3) When Room thermostat is set to ONE ZONE, the wired controller cannot be used to turn on/off Zone 1. Besides the timer related to DHW, all timers in Schedule are invalid. The unit can read the operating status of the unit, and set the operation mode (excluding Auto mode), and the temperature if the temperature curve is inactive.

4) When Room thermostat is set to DOUBLE ZONE, the wired controller cannot be used to turn on/off the Zone 1 or Zone 2. Besides the timer related to DHW, all timers in Schedule are invalid. The unit can read the operating status of the unit, and set the operation mode (excluding Auto mode), and the temperature if the temperature curve is inactive.

## 10.2.7 Other heat source

Other heat source	
IBH function	YES
dT1_IBH_ON	5°C
t_IBH_DELAY	15minutes
T4_IBH_ON	-15°C



Refer to 10.2.1 DHW setting for the operation method.

- 1) When EnSwitchPDC is set to NO, T4\_AHS\_ON can be set manually. When EnSwitchPDC is set to YES, T4\_AHS\_ON cannot be set manually.
- 2) When AHS function is set to NO, EnSwitchPDC is enforced to be NO.
- 3) When DHW mode is invalid, IBH function is enforced to be Heating.
- 4) When AHS function is set to NO, AHS\_PUMPI CONTROL is enforced to be RUN.

### 10.2.8 Service call

### Service call

Phone number 0000000000000000

Mobile number 0000000000000000

Up to two phone numbers can be saved, and the maximum length of the phone numbers is 15 characters. If the length is smaller than 15 character, use 0 in the front to indicate blank characters.

### 10.2.9 Restoration of factory settings

All the settings will come back to factory default. Do you want to restore factory settings?

NO | YES

Allow all operating parameters to be restored to the factory preset values. Select YES and confirm to validate this function.

### 10.2.10 Trail run

Refer to 11. Commissioning for further information.

### 10.2.11 Special function

### Special function

Preheating for floor >

Floor drying up >

### Preheating for floor

Provide mild heat to the underfloor water piping for initial heating operation to diminish the risk of damage to the floor and piping system.

### Preheating for floor

Preheating for floor

T1S 25°C

t\_ARSTH 72hours

Elapsed time --

### Preheating for floor

Tw\_out temp. 0°C

The first line is the operating status. Grey means it is off, and green means it is on.

T1S is the set temperature. t\_ARSTH is the duration. Elapsed time is the timefor which the function is enabled. Tw\_out temp. is the current leaving water temperature.

### Floor drying up

Provide mild heat to the concrete or other structural materials around the underfloor water piping in a certain period of time, accelerate the process of dehumidification.

### Floor drying up

Floor drying up

t\_Dryup 8days

t\_Highpeak 5days

t\_Drydown 5days

### Floor drying up

t\_Drypeak 45°C

Start time 00:00

Start date 12-02-2023

The first line is the status indicator. Grey means it is off, and green means it is on.

t\_Dryup is the time for which the unit rises the temperature. t\_Highpeak is the time for which the unit maintains the temperature. t\_Drydown is the time for which the unit drops the temperature. t\_Drypeak is the target temperature. This function will be enabled only when the time reaches the Start time and Start day.

When the function is enabled, you can see the interface as below.

### Floor drying up

Floor drying up is on.  
Tw\_out 15 °C  
The floor drying up is running for 3 days.

#### 10.2.12 Auto restart

### Auto restart

Auto restart cooling/heating mode	YES
Auto restart DHW mode	NO

Refer to 10.2.1 DHW setting for the operation method.

#### 10.2.13 Power input limitation

### Power input limitation

Power input limitation	1
------------------------	---

Refer to 10.2.1 DHW setting for the operation method.

#### 10.2.14 Input definition

### Input definition

M1 M2	Remote ON/OFF
Smart grid	NO
Tbt	NO
P_X port	Defrost

Refer to 10.2.1 DHW setting for the operation method.

#### 10.2.15 Cascade setting

### Cascade setting

PER_START	10%
TIME_ADJUST	5minutes

Refer to 10.2.1 DHW setting for the operation method.

#### 10.2.16 HMI address setting

### HMI address setting

HMI address for BMS	1
Stop BIT	1

Refer to 10.2.1 DHW setting for the operation method.

#### 10.2.17 Common setting

### Common setting

t_DELAY PUMP	2.0minutes
t_ANTILOCK PUMP	24hours
t2_ANTILOCK PUMP RUN	60seconds
t1-ANTILOCK SV	24hours

Refer to 10.2.1 DHW setting for the operation method.

### 10.3 Operation settings

Title	Code	State	Default	Minimum	Maximum	Set interval	Unit
DHW heating setting	DHW mode	Enable or disable DHW mode: 0=NO, 1=YES	1	0	1	1	/
	Disinfect	Enable or disable the disinfect mode: 0=NO, 1=YES	1	0	1	1	/
	DHW priority	Enable or disable DHW priority mode: 0=NO, 1=YES	1	0	1	1	/
	Pump_D	Enable or disable DHW pump mode: 0=NO, 1=YES	0	0	1	1	/
	DHW priority time set	Enable or disable DHW priority time setting: 0=NO, 1=YES	0	0	1	1	/
	dT5_ON	The temperature difference for starting DHW mode	10	1	30	1	°C
	dT1S5	The difference value between Twout and T5 in DHW mode	10	5	40	1	°C
	T4DHWMAX	The maximum ambient temperature at which the heat pump can operate for domestic water heating	46	35	46	1	°C
	T4DHWMIN	The minimum ambient temperature at which the heat pump can operate for domestic water heating	-10	-25	30	1	°C
	T5S_Disinfect	The target temperature of water in the domestic hot water tank in DISINFECT mode	65	60	70	1	°C
	t_DI_HIGHTEMP.	The time for which the highest temperature of water in the domestic hot water tank in DISINFECT mode lasts	15	5	60	5	Minutes
	t_DI_MAX	The maximum time for which disinfection lasts	210	90	300	5	Minutes
	t_DHWHP_Restrict	The operating time for heating/cooling	30	10	600	5	Minutes
	t_DHWHP_MAX	The maximum continuous operating time of the heat pump in DHW PRIORITY mode	90	10	600	5	Minutes
	Pump_D timer	Enable or disable the DHW pump to run as scheduled and to keep running for PUMP RUNNING TIME: 0=NO, 1=YES	1	0	1	1	/
Pump_D running time	The certain time for which the DHW pump keeps running	5	5	120	1	Minutes	
Pump_D disinfect	Enable or disable the DHW pump to operate when the unit is in DISINFECT mode and T5 is larger than or equal to T5S_DI-2: 0=NO, 1=YES	1	0	1	1	/	
Cooling setting	Cooling mode	Enable or disable the cooling mode:0=NO,1=YES	1	0	1	1	/
	t_T4_Fresh_C	The refresh time of climate-related curves in cooling mode	0.5	0.5	6	0.5	Hours
	T4CMAX	The highest ambient operating temperature in cooling mode	52	35	52	1	°C
	T4CMIN	The lowest ambient operating temperature in cooling mode	10	-5	25	1	°C
	dT1SC	The temperature difference for starting the heat pump (T1)	5	2	10	1	°C
	dTSC	The temperature difference for starting the heat pump (Ta)	2	1	10	1	°C
	Zone 1 C-emission	The type of Zone 1 terminal for cooling mode:0=FLH (floor heating), 1=FCU(fan coil unit), 2=RAD(radiator)	1	0	2	1	/
	Zone 2 C-emission	The type of Zone 2 terminal for cooling mode: 0=FLH (floor heating), 1=FCU(fan coil unit), 2=RAD(radiator)	1	0	2	1	/
Heating mode	Enable or disable the heating mode: 0=NO, 1=YES	1	0	1	1	/	

Heating setting	t_T4_Fresh_H	The refresh time of climate-related curves in heating mode	0.5	0.5	6	0.5	Hours
	T4HMAX	The maximum ambient operating temperature in heating mode	25	20	35	1	°C
	T4HMIN	The minimum ambient operating temperature in heating mode	-15	-25	30	1	°C
	dT1SH	The temperature difference for starting the unit (T1)	5	2	20	1	°C
	dTSH	The temperature difference for starting the unit (Ta)	2	1	10	1	°C
	Zone 1 H-emission	The type of Zone 1 terminal for heating mode: 0=FLH (floor heating) 1=FCU(fan coil unit), 2=RAD(radiator)	2	0	2	1	/
	Zone 2 H-emission	The type of Zone 2 terminal for heating mode: 0=FLH (floor heating) 1=FCU(fan coil unit), 2=RAD(radiator)	0	0	2	1	/
	Force defrost	Enable or disable the force defrost: 0=NO, 1=YES.	0	0	1	1	/
AUTO mode setting	T4AUTOCMIN	The minimum operating ambient temperature for cooling in auto mode	25	20	29	1	°C
	T4AUTOHMAX	The maximum operating ambient temperature for heating in auto mode	17	10	17	1	°C
Temp. type setting	Water flow temp.	Enable or disable the Water flow temp.: 0=NO, 1=YES	1	0	1	1	/
	Room temp.	Enable or disable the Room temp.: 0=NO, 1=YES	0	0	1	1	/
	Double zone	Enable or disable the Double zone: 0=NO, 1=YES	0	0	1	1	/
Room thermostat setting	Room thermostat	The style of room thermostat: 0=NO, 1=Mode set, 2=One zone, 3=Double zone	0	0	3	1	/
	Mode set priority	Select the priority mode in Room thermostat: 0=Heating, 1=Cooling	0	0	1	1	/
Other heat source	IBH function	Select the mode of IBH (Internal backup heater) : 0=Heating and DHW, 1=Heating	0 (DHW=valid) 1 (DHW=invalid)	0	1	1	/
	dT1_IBH_ON	The temperature difference between T1S and T1 for starting the backup heater	5	2	10	1	°C
	t_IBH_Delay	The time for which the compressor has run before startup of the first step backup heater	30	15	120	5	Minutes
	T4_IBH_ON	The ambient temperature for starting the backup heater	-5	-15	30	1	°C
	P_IBH1	Power input of IBH1	0.0	0.0	20.0	0.5	kW
	P_IBH2	Power input of IBH2	0.0	0.0	20.0	0.5	kW
	AHS function	Enable or disable the AHS (Auxiliary heating source) function: 0=NO, 1=Heating, 2=Heating and DHW	0	0	2	1	/
	AHS_Pump_I Control	Select the pump operating status when only AHS runs: 0=Run, 1=Not run	0	0	1	1	/
	dT1_AHS_ON	The temperature difference between T1S and T1 for starting the auxiliary heating source	5	2	20	1	°C
	t_AHS_Delay	The time for which the compressor has run before startup of the additional heating source	30	5	120	5	Minutes
	T4_AHS_ON	The ambient temperature for starting the additional heating source	-5	-15	30	1	°C
	EnSwitchPDC	Enable or disable automatic switch of heat pump and auxiliary heating source based on running cost: 0=NO, 1=YES	0	0	1	1	/
	GAS-COST	Price of gas	0.85	0.00	5.00	0.01	price/m <sup>3</sup>
ELE-COST	Price of electricity	0.20	0.00	5.00	0.01	price/kWh	

Other heat source	MAX-SETHEATER	Maximum set temperature of additional heating source	80	1	80	1	°C
	MIN-SETHEATER	Minimum set temperature of additional heating source	30	0	79	1	°C
	MAX-SIGHEATER	The voltage corresponding to the maximum set temperature of additional heating source	10	1	10	1	V
	MIN-SIGHEATER	The voltage corresponding to the minimum set temperature of additional heating source	3	0	9	1	V
	TBH function	Enable or disable the TBH (Tank booster heater) function: 0=NO, 1=YES	1	0	1	1	/
	dT5_TBH_OFF	The temperature difference between T5 and T5S (the set water tank temperature) for turning the booster heater off	5	0	10	1	°C
	t_TBH_DELAY	The time for which the compressor has run before startup of the booster heater	30	0	240	5	Minutes
	T4_TBH_ON	The ambient temperature for starting the tank booster heater	5	-5	50	1	°C
	P_TBH	Power input of TBH	2.0	0.0	20.0	0.5	kW
	Solar function	Enable or disable the Solar function: 0=NO, 1=Only solar, 2=Solar and HP (Heat Pump)	0	0	2	1	/
	Solar control	Solar pump (pump_s) control: 0=SL1SL2, 1=Tsolar	0	0	1	1	/
	Deltatsol	The temperature deviation for solar function running	10	5	20	1	°C
Special function	Preheating for floor	Enable or disable floor preheating: 0=NO, 1=YES	0	0	1	1	/
	T1S	The set outlet water temperature during first floor preheating	25	25	35	1	°C
	t_ARSTH	Running time for first floor preheating	72	48	96	12	Hours
	Floor drying up	Enable or disable floor drying: 0=NO, 1=YES	0	0	1	1	/
	t_Dryup	Temp-up days for floor drying	8	4	15	1	Days
	t_Highpeak	Days for floor drying	5	3	7	1	Days
	t_Drydown	Temp-down days for floor drying	5	4	15	1	Days
	t_Drypeak	Outlet water temperature for floor drying	45	30	55	1	°C
	Start time	The start time of floor drying	00:00	0:00	23:30	1/30	h/min
Start date	The start date of floor drying	Current date+1	Current date+1	31/12/2099	1/1/1	dd/mm/yyyy	
Auto restart	Auto restart cooling/heating mode	Enable or disable the auto restart of cooling/heating mode: 0=NO, 1=YES	1	0	1	1	/
	Auto restart DHW mode	Enable or disable the auto restart of DHW mode: 0=NO, 1=YES	1	0	1	1	/
Power input limitation	Power input limitation	The type of power input limitation	1	1	8	1	/
Input definition	M1 M2	Define the function of the M1M2 switch: 0=remote ON/OFF, 1=TBH ON/OFF, 2=AHS ON/OFF	0	0	2	1	/
	Smart grid	Enable or disable the smart grid: 0=NO, 1=YES	0	0	1	1	/
	T1T2	Control options of Port T1T2: 0=NO, 1=RT/Ta_PCB	0	0	1	1	/
	Tbt	Enable or disable the TBT: 0=NO, 1=YES	0	0	1	1	/
	P_X port	Select the function of P_X port: 0=Defrost, 1=Alarm	0	0	1	1	/
Cascade setting	PER_START	Percentage of operating units among all units	10	10	100	10	%
	TIME_ADJUST	Time interval for determining the necessity of unit loading/unloading	5	1	60	1	Minutes

HMI address setting	HMI address for BMS	Set the HMI address code for BMS	1	1	255	1	/
	Stop BIT	Upper computer stop bit: 1=STOP BIT1, 2=STOP BIT2	1	1	2	1	/
Common setting	t_Delay pump	The time for which the compressor has run before startup of the pump	2.0	0.5	20.0	0.5	Minutes
	t1_Antilock pump	The pump anti-lock interval	24	5	48	1	Hours
	t2_Antilock pump run	The pump anti-lock running time	60	0	300	30	Seconds
	t1_Antilock SV	The valve anti-lock interval	24	5	48	1	Hours
	t2_Antilock SV run	The valve anti-lock running time	30	0	120	10	Seconds
	Ta-adj.	The corrected value of Ta inside the wired controller	0	-10	10	1	°C
	Pump_I silent output	The Pump_I max output limitation	100	50	100	5	%
	Energy metering	Enable or disable the energy analysis: 0=NO, 1=YES	1	0	1	1	/
	Pump_O	Additional circulation pump operation: 0=ON (keep running) 1=Auto (controlled by the unit)	0	0	1	1	/
	Glycol	Glycol application: 0=Without glycol, 1=With glycol	0	0	1	1	/
	Glycol concentration	Glycol added concentration	10	10	30	5	%
Pump_I minimum output	Circulation pump Pump_I operating lowest limit	30	30	80	5	%	
Intelligent function settings	Energy correction	Correction for Energy metering	0	-50	50	5	%
	Sensor backup mode	Sensor backup operation function, 0 =NO, 1=YES	1	0	1	1	/

## NOTE

Please set P\_IBH1, P\_IBH2, P\_TBH according to the field installation. If the values are different with the actual values, the energy metering calculation could deviate from actual situation.

## 11 COMMISSIONING

Test run is used to confirm the functionality of the valves, air purge, circulation pump operation, cooling, heating and domestic water heating.

**Test run**

Point check >|

Air purge >

Circulated pump running >

Cooling running >

**Test run**

Heating running >|

Cooling running >

DHW running >

Checklist during commissioning

<input type="checkbox"/>	Test run for the actuator
<input type="checkbox"/>	Air purge
<input type="checkbox"/>	Test run for operation
<input type="checkbox"/>	Check of the minimum flow rate

### 11.1 Test run for the actuator

## NOTE

During the commissioning of the actuator, the protection function of the unit is disabled. Excessive use may damage components.

#### Why

Check whether each actuator is in good working conditions.

## What - Actuator List

No.	Name		Note
1	SV2	Three-way valve 2	
2	SV3	Three-way valve 3	
3	PUMP_I	Integrated circulation pump	
4	PUMP_O	Additional circulation pump(for Zone 1)	
5	PUMP_C	Zone 2 pump	
6	IBH	Internal backup heater	
7	AHS	Additional heat source	
8	SV1	Three-way valve 1	Invisible if DHW is disabled
9	PUMP_D	DHW pump	Invisible if DHW is disabled
10	PUMP_S	Solar heating loop circulation pump	Invisible if DHW is disabled
11	TBH	Tank booster heater	Invisible if DHW is disabled

## How

1	Go to "FOR SERVICEMAN" (Refer to 10.2 Configuration).
2	Find "Test run" and enter the process.
3	Find "Point check" and enter the process.
4	Select the actuator, and press <input type="radio"/> to activate or deactivate the actuator. <ul style="list-style-type: none"> <li>The status ON means the actuator is activated, and OFF means the actuator is deactivated.</li> </ul>

## NOTE

When you return to the upper layer, all actuators turn OFF automatically.

## 11.2 Air purge

### Why

To purge out the remaining air in the water loop.

### How

1	Go to "FOR SERVICEMAN" (Refer to 10.2 Configuration).
2	Find "Test run and enter the process.
3	Find "Air purge" and enter the process.
4	Select "Air purge" and press <input type="radio"/> to activate or deactivate the air purge function. <ul style="list-style-type: none"> <li><input checked="" type="radio"/> means the air purge function is activated, and <input type="radio"/> means the air purge function is deactivated.</li> </ul>

### Besides

"Air vent pump_i output"	To set pump_i output. The higher the value is, the pump gives a higher output.
"Air vent running time"	To set the duration of air purge. When the set time is due, air purge is deactivated.
"Status check"	Additional operation parameters can be found.

## 11.3 Test run

### Why

Check whether the unit is in good working conditions.

### What

Circulated pump operation  
 Cooling operation  
 Heating operation  
 DHW operation

### How

1	Go to "FOR SERVICEMAN" (Refer to 10.2 Configuration)
2	Find "Test run" and enter the page.
3	Find "Other" and enter the process.
4	Select "XXXX"* and press <input type="radio"/> to run the test. During test, press <input type="radio"/> , select OK and confirm to return to the upper layer. * - Four performance test options are shown in <b>What</b> .

## NOTE

In performance test, the target temperature is preset and cannot be changed.  
 If the outdoor temperature is outside the range of operating temperature, the unit may not operate or may not deliver the required capacity.  
 In circulated pump operation, If the flow rate is out of recommended flow rate range, please make proper change of the installation, and ensure that the flow rate in the installation is guaranteed in all conditions.

### 11.4 Check of the minimum flow rate

1	Check the hydraulic configuration to find out the space heating loops that can be closed by mechanical, electronic, or other valves.
2	Close all space heating loops that can be closed.
3	Start and operate the circulation pump (See "11.3 Test Run").
4	Read out the flow rate <sup>(a)</sup> and modify the bypass valve settings until the set value reaches the minimum flow rate required + 2 l/min.

(a) During pump trail run, the unit can operate below the minimum required flow rate.

## 12 HAND-OVER TO THE USER

Once the trail run is finished and the unit operates properly, please make sure the following is clear for the user:

- Fill the installer setting table (in the OPERATION MANUAL) with the actual settings.
- Empty the error history in the HMI before hand-over to the user.
- It is highly recommended to do the WLAN connection of the unit. You can read more information in the APP.
- Make sure that the user has the printed documentation and ask him/her to keep it for future reference.
- Explain to the user how to properly operate the system and what to do in case of problems.

-Basic operation guidelines can be found in the OPERATION MANUAL.

-For additional information about operation, see 12.2 Additional Operation Reference.

- Show the user what to do for the maintenance of the unit.
- Explain to the user about energy saving tips as described below.

### 12.1 Energy saving tips

#### Tips about room temperature

- Make sure the desired room temperature is NEVER too high (in heating mode) or too low (in cooling mode), and ALWAYS set it according to your actual needs. An rise/drop of one degree centigrade can save up to 6 % of heating/cooling costs.
- Do NOT increase/decrease the desired room temperature to speed up space heating/cooling as such operation cannot accelerate the heating/cooling process.
- When your system layout contains slow heat emitters (such as underfloor heating), avoid large fluctuations of the desired room temperature and do NOT drop or rise the room temperature excessively. Otherwise, it will take more time and energy to heat up/cool down the room again.
- Use a weekly schedule to meet your normal space heating or cooling needs. If necessary, you can easily deviate from the schedule:
  - 1) For shorter periods: You can override the scheduled room temperature until the next scheduled action starts. For example, you can do this when you have a party, or when you are leaving for a couple of hours.
  - 2) For longer periods: You can use the holiday mode.

#### Tips about DHW tank temperature

- Use a weekly schedule to meet your normal domestic hot water needs (only in scheduled mode).
- Program to heat up the DHW tank to a preset value during the night, because the space heating demand during such period is low.
  - If heating up the DHW tank only at night is not sufficient, program to additionally heat up the DHW tank to a preset value during the day.
- Make sure the desired DHW tank temperature is NOT too high. For example, after installation, lower the DHW tank temperature daily by 1°C and check if you still have enough hot water.
  - Program to turn ON the domestic hot water pump only during periods of the day when instant hot water is necessary, such as in the morning and evening.

### 12.2 Additional operation reference

#### 12.2.1 Mode

##### What

Set the unit operation mode for room comfort.

- Three modes in all – Space heating mode, space cooling mode, and auto mode.

AUTO mode	The unit will select the operation mode automatically based on the outdoor ambient temperature and some settings in "FOR SERVICEMEN". <ul style="list-style-type: none"> <li>• This icon is invisible if either the heating function or cooling function is disabled.</li> </ul>
Heating	The icon of heating is invisible if the heating function is disabled.
Cooling	The icon of cooling is invisible if the cooling function is disabled.



## 12.2.2 Schedule

### What

Make unit operation plans.

- This function is based on the current time displayed on the HMI. Make sure the time is correct.

### Conflicts and operation priority

- 1) A daily schedule and a weekly schedule can work simultaneously.
- 2) For all schedules, timers (if more than one) for the same zone or appliance must be different, and the operation mode of Zone 1 and Zone 2 in the same time setting must be the same. Otherwise, the most recent setting is invalid, and a notice window appears.
- 3) When the unit is in Holiday away or Holiday home mode, the daily timer, weekly timer and temperature curve function (11.2.3 Weather temp. setting) become invalid and will not recover until the unit quits Holiday away and Holiday home mode.
- 4) If Holiday away and Holiday home mode are active simultaneously, the date for both the modes cannot be overlapped. Otherwise, the most recent setting is invalid, and a notice window appears.

### More

- 1) All daily schedules and weekly schedules become inactive, the set time turns to 0:00, and the set temperature turns to 24 °C in case of any change of the temperature control mode .
- 2) The unit runs disinfection based on the settings of 11.2.4 DHW setting, if the disinfection function in Holiday away mode is inactive.
- 3) In case of power failure during Holiday away or Holiday home mode, the unit will run in Holiday away or Holiday home mode after power restoration if the current date is still within the period for Holiday away or Holiday home mode.
- 4) If the mode setting is OFF, the set temperature turns to 0 °C.

## 12.2.3 Weather temp. setting

### What

Allow the set water temperature to regulate depending on the outdoor ambient temperature.

- This function is only applicable to space heating and space cooling. When the function is active, the unit will apply the temperature curve if the current operation mode is set the same as that of the activated function.
- Three types of curves in all – Standard, ECO, Custom.

Illustration of temperature curve

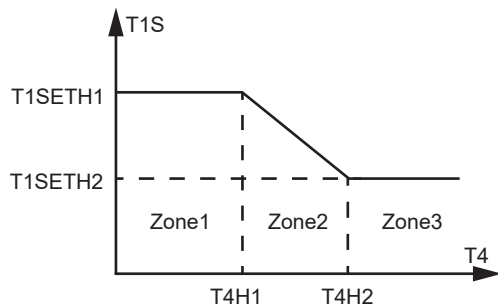

T1S – set water temperature

T4 – outdoor ambient temperature

In Zone 1 and Zone 3, the set water temperature remains stable despite the change of the outdoor ambient temperature. In Zone 2, the set water temperature regulates depending on the outdoor ambient temperature.

### Standard

Up to 8 curves are preset by the manufacturer, and the parameter values are as below.

For heating:

	$T4 < 0$	$0 \leq T4 < 20$	$T4 \geq 20$
1-T1S	$0.175 * (0 - T4) + 25$	$0.25 * (20 - T4) + 20$	20
2-T1S	$0.35 * (0 - T4) + 30$	$0.5 * (20 - T4) + 20$	20
3-T1S	$0.525 * (0 - T4) + 35$	$0.75 * (20 - T4) + 20$	20
4-T1S	$0.63 * (0 - T4) + 38$	$0.9 * (20 - T4) + 20$	20
5-T1S	$0.875 * (0 - T4) + 45$	$1.25 * (20 - T4) + 20$	20
6-T1S	$0.98 * (0 - T4) + 48$	$1.4 * (20 - T4) + 20$	20
7-T1S	$1.225 * (0 - T4) + 55$	$1.75 * (20 - T4) + 20$	20
8-T1S	$1.4 * (0 - T4) + 60$	$2 * (20 - T4) + 20$	20

Illustration of all 8 curves

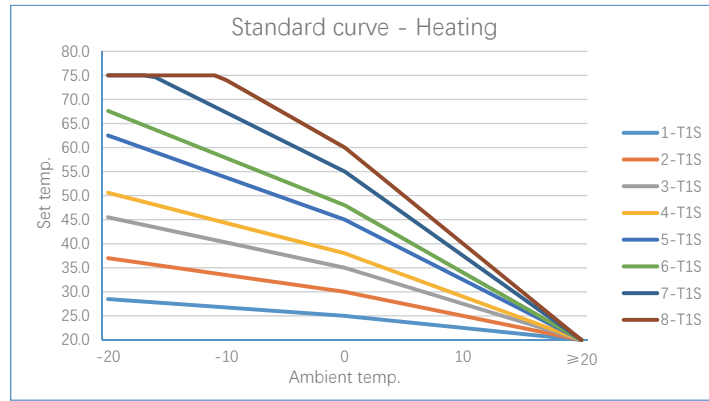

For cooling (FCU – fan coil application):

T4	-10≤T4 < 15	15≤T4 < 22	22≤T4 < 30	30≤T4
1-T1S	16	11	8	5
2-T1S	17	12	9	6
3-T1S	18	13	10	7
4-T1S	19	14	11	8
5-T1S	20	15	12	9
6-T1S	21	16	13	10
7-T1S	22	17	14	11
8-T1S	23	18	15	12

For cooling (RAD – radiator application, FLH – underfloor heating application):

T4	-10≤T4 < 15	15≤T4 < 22	22≤T4 < 30	30≤T4
1-T1S	20	18	18	18
2-T1S	21	19	18	18
3-T1S	22	20	19	18
4-T1S	23	21	19	18
5-T1S	24	21	20	18
6-T1S	24	22	20	19
7-T1S	25	22	21	19
8-T1S	25	23	21	20

Illustration of all 8 curves

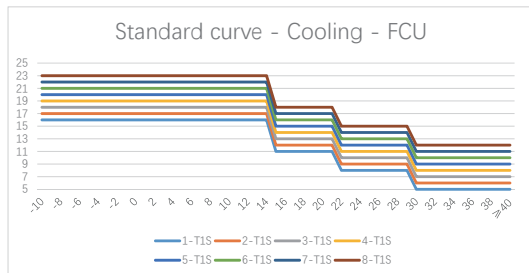
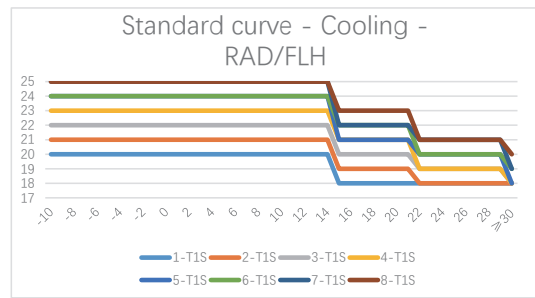

Illustration of all 8 curves



About Temperature offset

It makes the overall set water temperature of the temperature curve increase or decrease. The temperature curve rises or drops in the illustration.

ECO

**NOTE**

ECO is available for Zone 1 heating mode only.

T4	≤-20	-19	-18	-17	-16	-15	-14	-13	-12	-11	-10	-9	-8	-7	-6	-5	-4	-3	-2	-1	0
1-T1S	29	29	29	29	28	28	28	28	28	28	28	28	27	27	27	27	27	27	25	25	25
2-T1S	32	32	32	32	31	31	31	31	31	31	31	31	30	30	30	30	30	30	30	30	30
3-T1S	38	38	38	38	38	37	37	37	37	37	37	36	36	36	36	36	36	35	35	35	35
4-T1S	40	40	40	40	39	39	39	39	39	39	39	39	38	38	38	38	38	38	38	38	37
5-T1S	45	45	45	45	44	44	44	44	44	44	44	44	43	43	43	43	43	43	43	43	42
6-T1S	48	48	48	48	47	47	47	47	47	47	47	47	46	46	46	46	46	46	46	46	45
7-T1S	52	52	52	52	51	51	51	51	51	51	51	51	50	50	50	50	50	50	50	50	49
8-T1S	55	55	55	55	54	54	54	54	54	54	54	54	53	53	53	53	53	53	53	53	52
T4	1	2	3	4	5	6	7	8	9	10	11	12	13	14	15	16	17	18	19	≥20	
1-T1S	24	24	24	24	23	23	23	23	22	22	22	22	21	21	21	21	20	20	20	20	20
2-T1S	29	29	28	28	27	27	26	26	25	25	24	24	23	23	22	22	21	21	20	20	20
3-T1S	34	33	32	32	31	30	29	29	28	27	26	26	25	24	23	23	22	21	20	20	20
4-T1S	37	36	35	34	33	32	31	30	29	29	28	27	26	25	24	23	22	21	20	20	20
5-T1S	42	42	41	40	38	37	36	35	33	32	31	30	28	27	26	25	23	22	21	20	20
6-T1S	45	45	43	42	41	39	38	36	35	34	32	31	29	28	27	25	24	22	21	20	20
7-T1S	49	49	49	48	46	44	42	41	39	37	35	34	32	30	28	27	25	23	21	20	20
8-T1S	52	52	52	52	50	48	46	44	42	40	38	36	34	32	30	28	26	24	22	20	20

Illustration of all 8 curves

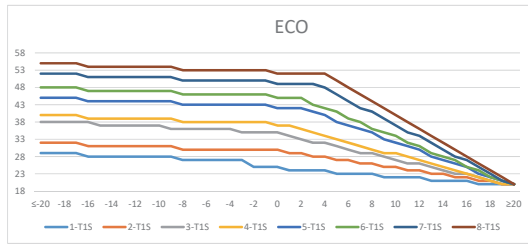

You can see “ECO timer” at the bottom of the page. You can set the start time and end time of the timer and activate the timer. If the timer is active, the unit will execute the ECO curve only during the set period of the timer. If the timer is inactive, the unit will execute the ECO curve all the way.

### Custom

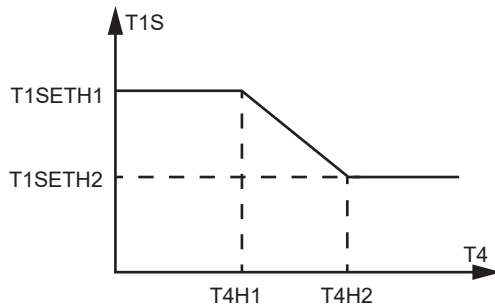

T1S – Set water temperature

T4 – Outdoor ambient temperature

T1SETH1, T1SETH2, T4H1, and T4H2 can be adjusted.

### NOTE

The illustration on HMI is for reference only. If the set T1SETH1 is lower than T1SETH2 or T4H2 is lower than T4H1, the unit will reverse T1SETH1 and T1SETH2, T4H1 and T4H2 automatically.

### 12.2.4 DHW setting

### NOTE

Invisible if DHW MODE is disabled.

#### What

More settings of DHW.

#### Disinfection

- When the unit is running in disinfection mode with DHW on, if you turn off DHW on the home page, the unit will ask if you want to disable the disinfection. If you confirm the disablement, a notice window will appear.

### NOTE

If any timer of DHW OFF is during the disinfection working. Then the disinfection will be turned off automatically without any notice.

- When the unit is running in disinfection mode with DHW off, if you turn on DHW on the home page, the disinfection continues.

### Tank heater

The tank heater and backup heater cannot operate simultaneously. The most recent setting is valid while the previous setting becomes invalid

- For instance, when the backup heater is valid and running, if the tank heater is turned off, the backup heater stops running.

### 12.2.5 Options

#### What

More general settings.

#### Silent mode

The start time and end time of the silent mode timer cannot be identical.

If two silent mode timers are activated simultaneously, the date of both the timers cannot be overlapped. Otherwise, the most recent setting is invalid, and a notice window appears.

#### Backup heater

Invisible if IBH and AHS are disabled.

#### WLAN setting

In case of any change of the WIFI name, the unit will lost WLAN connection and need to be reconnected.

#### Force defrost

Invisible if the unit is running in cooling mode.

### 12.2.6 Unit status

#### What

More information of the unit and its operation status.

#### Operating parameter

The run time is rounded down. For instance, if the unit is hour, and the actual run time is 0.5 h, the displayed value is 0.

#### Energy metering

For accumulated data(Day, Week, Month, Year),

- The start time is the beginning of that day, week, month, year.
- If the time of HMI is reset and there is data logging from the beginning of that day, week, month, year, the calculation will start from the beginning of that day, week, month, year.
- If the time of HMI is reset and there is no data logging from the beginning of that day, week, month, or year, the calculation will start from the time when the resetting occurs.

For Historical data,

- It records up to 10-year data. For instance, if the unit starts running from 2023, when it comes to 2035, you can check the data only from 2025 to 2035.

### 12.2.7 Error info

#### What

Error history of the unit.

The first column shows the unit number, if slave units are available.

Press the Menu button for 5 seconds to clear all error records.

### 12.2.8 FAQ

#### What

Assistance for common questions.

## 13 TROUBLESHOOTING

This section provides useful information about diagnosing and correcting certain problems that may occur to the unit.

### 13.1 General Guidelines

- Before starting the troubleshooting procedure, visually inspect the unit and look for obvious defects such as loose connections or defective wiring.
- When a safety device is activated, stop the unit and find out the cause of such activation before resetting the safety device. Under no circumstances can safety devices be bridged or unit parameters be changed. If the cause of the problem cannot be found, call the local dealer.
- If the pressure relief valve does not work properly or should be replaced, always reconnect the flexible hose attached to the pressure relief valve to prevent water from dripping out of the unit.

#### NOTE

For problems related to the optional solar kit for domestic water heating, refer to the troubleshooting in the documents for the kit.

### 13.2 Typical abnormalities

Symptom 1: the unit is turned on but the unit fails to operate in cooling or heating mode as expected.

POSSIBLE CAUSE	TROUBLESHOOTING
Incorrect temperature setting	Check the parameters (T4HMAX and T4HMIN in heating mode; T4CMAX and T4CMIN in cooling mode; T4DHWMAX and T4DHWMIN in DHW mode). For the parameter range, please refer to . 10.3 Operation Settings.
Too small water flow	<ul style="list-style-type: none"> <li>• Verify that all shut off valves of the water loop are in the right position.</li> <li>• Check if the water filter is plugged.</li> <li>• Make sure there is no air in the water system.</li> <li>• Check the water pressure.</li> </ul> The water pressure must be larger than or equal to 1.5 bar.
Too small water volume in the installation	Make sure that the water volume in the installation is above the minimum required value. Please refer to 6.1 Preparations for Installation.

Symptom 2: the unit is turned on but the compressor fails to start.

POSSIBLE CAUSE	TROUBLESHOOTING
The unit may operate out of its operating range (too low water temperature).	In case of low water temperature, the system starts the backup heater to reach the minimum water temperature first (12 °C). <ul style="list-style-type: none"> <li>• Verify that the power supply for the backup heater is correct.</li> <li>• Verify that the thermal fuse of the backup heater is closed.</li> <li>• Verify that the thermal protector of the backup heater is not activated.</li> <li>• Verify that the contactors of the backup heater are not broken.</li> </ul>

Symptom 3: noise is generated from the pump (cavitation).

POSSIBLE CAUSE	TROUBLESHOOTING
Air in the system.	Purge the air.
Too small water pressure at the pump inlet	<ul style="list-style-type: none"> <li>• Check the water pressure.</li> </ul> The water pressure must be larger than or equal to 1.5 bar. <ul style="list-style-type: none"> <li>• Verify that the expansion vessel is not broken.</li> <li>• Verify that the pre- pressure of the expansion vessel is set correctly. See 6.1 Preparations for Installation.</li> </ul>

Symptom 4: the water pressure relief valve opens.

POSSIBLE CAUSE	TROUBLESHOOTING
Broken expansion vessel	Replace the expansion vessel.
Water pressure in the installation higher than 0.3 MPa.	Make sure that the water pressure in the installation is within 0.10 to 0.20 MPa.

Symptom 5: the water pressure relief valve leaks.

POSSIBLE CAUSE	TROUBLESHOOTING
Blockage of water pressure relief valve outlet	<ul style="list-style-type: none"> <li>• Check for correct operation of the pressure relief valve by turning the black knob on the valve counterclockwise:</li> <li>• If you do not hear a clacking sound, contact your local dealer.</li> <li>• In case water keeps running out of the unit, close the shut-off Valves at both the water inlet and outlet, and then contact your local dealer.</li> </ul>

Symptom 6: insufficient space heating capacity at low outdoor temperature.

POSSIBLE CAUSE	TROUBLESHOOTING
Backup heater not activated	<ul style="list-style-type: none"> <li>• Check whether the IBH function is enabled.</li> <li>• Check whether the thermal protector of the backup heater has been activated.</li> <li>• Check whether the booster heater is running. The backup heater and booster heater can not operate simultaneously.</li> </ul>
Excessive heat pump capacity used for heating domestic hot water (applicable only to installations with a domestic hot water tank).	Verify that the "t_DHWHP_MAX" and "t_DHWHP_RESTRICT" are configured appropriately: <ul style="list-style-type: none"> <li>• Make sure that the "DHW PRIORITY" in the wired controller is disabled.</li> <li>• Enable the "T4_TBH_ON" in the wired controller/FOR SERVICEMEN to activate the booster heater for domestic water heating.</li> </ul>

Symptom 7: the unit cannot switch from Heating mode to DHW mode immediately.

POSSIBLE CAUSE	TROUBLESHOOTING
Too small volume of tank and low location of water temperature probe	<ul style="list-style-type: none"> <li>• Set "dT1S5" to the maximum valve, and set "t_DHWHP_RESTRICT" to the minimum valve.</li> <li>• Set dT1SH to 2 °C.</li> <li>• Enable the TBH. The TBH should be controlled by the ODU.</li> <li>• If AHS is available, turn on it. the heat pump will turn on once the requirements for turning it on are met.</li> <li>• If both the TBH and AHS are not available, try to change the position of the T5 probe (Refer to 3.2 DHW Tank (Supplied by the User)).</li> </ul>

Symptom 8: the unit cannot switch from DHW mode to Heating mode immediately

POSSIBLE CAUSE	TROUBLESHOOTING
Small heat exchanger for space heating	<ul style="list-style-type: none"> <li>• Set "t_DHWHP_MAX" to the minimum valve. The suggested valve is 60 min.</li> <li>• If the circulation pump out of the unit is not controlled by the unit, try to connect it to the unit.</li> <li>• Add a 3-way valve at the inlet of the fan coil to provide enough water flow.</li> </ul>
Small space heating load	Normal , no need for heating
Disinfection function enabled without TBH	<ul style="list-style-type: none"> <li>• Disable the disinfection function</li> <li>• Add a TBH or AHS for DHW operation</li> </ul>
The FAST WATER function is manually turned on after the hot water meets the requirements, and the heat pump fails to switch to the air-conditioning mode in time when air conditioning is required.	Manually turn off the FAST WATER function
In case of a low ambient temperature, the hot water is not enough and the AHS fails to operate or fails to operate in time.	<ul style="list-style-type: none"> <li>• Set "T4DHWMIN". The suggested valve is larger than or equal to -5 °C</li> <li>• Set "T4_TBH_ON". The suggested valve is larger than or equal to 5 °C</li> </ul>
DHW mode priority	If there is an AHS or IBH connected to the unit, when the ODU fails, the hydraulic module board must run DHW mode till the water temperature reaches the set value before change to heating mode.

Symptom 9: The heat pump stops operating in DHW mode although the set temperature is not reached, and space heating is required but the unit stays in DHW mode.

POSSIBLE CAUSE	TROUBLESHOOTING
Small surface of coil in the tank	Same as Symptom 7
TBH or AHS not available	The heat pump will stay in DHW mode until "t_DHWHP_MAX" or the set temperature is reached. Add a TBH or AHS for DHWoperation. The TBH and AHS should be controlled by the unit.

### 13.3 Error codes

The explanation about each error code can be found on the wired controller.

Reset the unit by powering off and powering on it.

If resetting the unit is invalid, contact the local dealer.

## ⚠ CAUTION

In winter, if the unit suffers from E0 and Hb malfunction and the unit is not repaired in time, the water pump and pipeline system may be damaged due to freezing.  
Take proper measures to eliminate the E0 and Hb malfunction.

## 14 MAINTENANCE

Regular checks and inspections at certain intervals are required to guarantee the optimal performance of the unit.

### 14.1 Safety precautions for maintenance

#### DANGER

Risk of electrocution.

#### WARNING

- Please note that some parts of the electric component box are hot.
- Do not rinse the unit. Otherwise, electric shock or fire may occur.
- Do not leave the unit unattended when the service panel is removed.

#### NOTE

- Before performing any maintenance or service work, touch a metal part of the unit to eliminate static electricity and to protect the PCB.
- Without regular maintenance, the performance of the unit may degrade and the risk of parts damage may increase gradually.

### 14.2 Maintenance checklist

#### By user

Items	Recommended frequency
Clean the surrounding of the outdoor unit.	Once a month.

#### By installer

Items	Recommended frequency
General	
Check if all the parts are in the proper position.	Once a year.
Water loop	
Check if the water pressure is sufficient.	Once a year.
Clean the strainer in water system.	Once a year.
Check if the flow switch works in good condition.	Once a year.
Check if the water pressure relief valve (in water system) works in good condition.	Once a year.
Check if the water pressure relief valve (in DHW water loop) works in good condition.	Once a year.
Check if the insulation of backup heater is in good condition.	Once a year.
Check if there is water leakage in the water loop. Take care if anti-refrigerant is applied.	Once a year.
Check if the booster heater of DHW water tank is clean and in good condition.	Once a year.
Wiring and electrical parts	
Check if the temperature sensor works in good condition.	Once a year.
Check if the wiring and cables of the installation is in good condition.	Once a year.
Check if the contactors and circuit breakers works in good condition.	Once a year.
Refrigerant loop	
Check if there is refrigerant leakage in the refrigerant loop.	Once a year.

#### NOTE

Ask the supplier and refer to the SERVICE MANUAL for more information.

## 15 SERVICE INFORMATION

### 15.1 Label for refrigerant presence

Equipment should be provided with a label stating that it has been de-commissioned and emptied of refrigerant. The label should be dated and signed. Ensure that proper labels are pasted on the equipment stating the equipment contains flammable refrigerant.

### 15.2 Leak detection methods

The following leak detection methods are deemed acceptable for systems containing flammable refrigerants. An electronic leak detector should be used to detect flammable refrigerants, but its sensitivity may not be adequate, or the detector may need re-calibration. (Detection equipment should be calibrated in a refrigerant-free area.) Ensure that the detector is not a potential source of ignition and is suitable for the refrigerant. Leak detection equipment should be set at a percentage of the LFL of the refrigerant and should be calibrated to be suitable for the refrigerant employed. The appropriate percentage of gas (25 % maximum) is confirmed. Leak detection fluids are suitable for use with most refrigerants but detergents containing chlorine should not be used as the chlorine may react with the refrigerant and corrode the copper pipes. If a leak is suspected, all naked flames should be removed or extinguished. If a leakage of refrigerant is found and brazing is required, all of the refrigerant should be recovered from the system, or isolated (by means of shut off valves) in a part of the system that is remote from the leak. Oxygen free nitrogen (OFN) should then be purged through the system both before and during the brazing process.

### 15.3 Check of refrigeration equipment

Where electrical components are to be changed, they should be fit for the intended purpose and comply with the correct specifications. Always follow the manufacturer's maintenance and service guidelines. In case of any doubt, consult the manufacturer's technical department for assistance. Check installations using flammable refrigerants.

- The amount of refrigerant to be charged depends on the size of the room where the refrigerant-containing parts are installed.
- The ventilation machinery and outlets should work adequately and be not obstructed.
- If an indirect refrigerating circuit is used, the secondary circuits should be checked for any refrigerant; Markings on the equipment should be visible and legible.
- Illegible markings and signs should be corrected.
- Refrigeration pipes or components should be installed in a positions where they are unlikely to be exposed to any substance that may corrode refrigerant-containing components, unless the components are constructed of materials that are inherently resistant to corrosion or are suitably protected from corrosion.

### 15.4 Check of electrical devices

Repair and maintenance of electrical components should include initial safety checks and component inspection procedures. If a fault exists and could compromise safety, no electrical supply should be connected to the circuit until it is satisfactorily dealt with. If the fault cannot be corrected immediately but it is necessary to continue operation, an adequate temporary solution should be adopted. This should be reported to the owner of the equipment so all parties are advised.

Initial safety checks should include the following:

- The capacitors should be discharged in a safe manner to avoid sparking risks.

- No live electrical components and wiring can be exposed during the system charging, recovery or purging.
- Earth bonding should be continuous.

### 15.5 Repair of sealed components

a) During repair of sealed components, all electrical supplies should be disconnected from the equipment being worked upon prior to any removal of sealed covers. If it is absolutely necessary to have an electrical supply connected with the equipment during servicing, a permanently operating form of leak detection should be located at the most critical point to warn of a potentially hazardous situation.

b) Particular attention should be paid to the following to ensure that, by working on electrical components, the casing is not altered in such a way that the protection is compromised. This should include damage to cables, an excessive number of connections, terminals not made as per original specifications, damage to seals, and incorrect fitting of glands.

- Ensure that all apparatuses are mounted securely.
- Ensure that seals or sealing materials have not degraded such that they can no longer prevent the ingress of flammable atmospheres. Parts for replacement should be in accordance with the manufacturer's specifications.
- The use of silicon sealant may inhibit the effectiveness of some types of leak detection equipment. Intrinsically safe components do not have to be isolated prior to working on them.

### 15.6 Repair of intrinsically safe components

Do not apply any permanent inductive or capacitance loads to the circuit without ensuring that such loads will not exceed the permissible voltage or current permitted for the equipment in use. Intrinsically safe components are the only types that can be worked on when the components live in a flammable atmosphere. The test apparatus should be provided with the correct rating. Replace components only with parts specified by the manufacturer. Other parts may result in the ignition of refrigerant in the atmosphere caused by a leak.

### 15.7 Transportation and marking

Transport the equipment containing flammable refrigerants in accordance with the transport regulations. Mark the equipment with signs in compliance with local regulations.

## 16 DISPOSAL

### General

Components and accessories of the unit are not ordinary domestic wastes.

The unit, compressors, and motors, etc. can only be disposed of by qualified specialists.

This unit uses hydrofluorocarbon that can only be disposed of by qualified specialists.

### Packaging

- Dispose of the packaging properly.
- Observe all relevant regulations.



### Refrigerant

Refer to 16.1 Refrigerant Removal, Evacuation, Charge, Recovery, and Unit Decommissioning.

### 16.1 Refrigerant Removal, Evacuation, Charge, Recovery, and Unit Decommissioning

#### **WARNING**

Due to the feature of the R290 refrigerant, only carry out work when you have specific expert

refrigeration knowledge and are competent for handling R290 refrigerant.

### 1) Removal and evacuation

When breaking into the refrigerant circuit for repair or any other purpose, follow the conventional procedures. However, it is important to follow the best practice since flammability should be considered. Operate as per the following procedure:

- Remove refrigerant;
- Purge the circuit with inert gas;
- Evacuate;
- Purge the circuit again with inert gas;
- Open the circuit by cutting or brazing

The refrigerant charged should be recovered and put in correct recovery cylinders. The system should be flushed with OFN to guarantee the unit safety. This process may need to be repeated several times. Compressed air or oxygen should not be used.

Flushing should be achieved by filling the system with OFN until the working pressure is achieved before venting to the atmosphere, and recovering the system to a vacuum. This process should be repeated until no refrigerant exists in the system.

Upon the final OFN charge, the system should be vented down to reach the atmospheric pressure to start the work.

This operation is absolutely vital if brazing operations on the pipe-work are to take place.

Ensure that the outlet of the vacuum pump is not closed to any ignition sources and adequate ventilation is available.

### 2) Charging procedures

In addition to conventional charging procedures, the following requirements should be followed:

- Ensure that contamination of different refrigerants does not occur when charging equipment is used. Hoses or lines should be as short as possible to minimize the amount of refrigerant contained in them.
- Earth the refrigeration system prior to charging the system with refrigerant.
- Label the system upon completion of the charging (if the system has not been labeled).
- Extreme care should be taken not to overfill the refrigeration system.
- Prior to recharging the system, test it with OFN. The system should be leak tested upon completion of charging but prior to commissioning. Carry out a follow-up leak test before leaving the site.

### 3) Recovery

When removing refrigerant from the system, either for service or decommissioning, we recommend you remove all refrigerants safely by following the best practice.

When transferring refrigerant into cylinders, only use appropriate refrigerant recovery cylinders. Ensure that a proper number of cylinders are available for accommodating all the refrigerant. All cylinders to be used are designated and labeled for the recovered refrigerant (i.e., special cylinders for the recovery of refrigerant). The cylinders should be complete with pressure relief valves and associated shut-off valves that work properly.

Empty recovery cylinders should be evacuated and, if possible, cooled before the recovery starts.

The recovery equipment should work properly with a set of instructions concerning the equipment at hand, and should be suitable for the recovery of flammable refrigerants. In addition, a set of calibrated weighting scales

should be available and work properly. Hoses should be complete with leak-free disconnection couplings and in good conditions. Before using the recovery equipment, check and verify that it works properly and has been properly maintained, and that any associated electrical components are sealed to prevent ignition in the event of a refrigerant leakage. Consult the manufacturer in case of any doubt.

The recovered refrigerant should be returned to the refrigerant supplier in correct recovery cylinders, with the relevant Waste Transfer Note arranged. Do not mix refrigerants in recovery units, especially in cylinders.

If compressors or compressor oils are to be removed, ensure that they have been evacuated to an acceptable level to ensure that flammable refrigerant does not remain within the lubricant. Carry out the evacuation process before returning the compressor to the suppliers. To accelerate this process, you can only heat the compressor body electrically. Safety drain oil from the system.

### 4) ecommissioning

Prior to this procedure, the technician should be completely familiar with the equipment and all its details. It is recommended that all refrigerants be recovered safely. Prior to the recovery, an oil and refrigerant sample should be taken for case analysis before re-use of reclaimed refrigerant. Electrical power should be available before the task is commenced.

- a) Be familiar with the equipment and its operation.
- b) Isolate the system electrically
- c) Before attempting the procedure ensure that:
  - mechanical handling equipment is available, if required, for handling refrigerant cylinders.
  - All personal protective equipment should be available and used correctly.
  - The recovery process should be supervised at all time by a competent person.
  - Recovery equipment and cylinders should conform to the appropriate standards.
- d) Pump down the refrigerant system, if possible.
- e) If a vacuum is not possible, provide a manifold to remove the refrigerant from various parts of the system.
- f) Make sure that the cylinders are situated on the scales before the recovery starts.
- g) Start the recovery machine and operate it in accordance with the manufacturer's instructions.
- h) Do not overfill the cylinders (for no more than 80 % of the volume).
- i) Do not exceed the maximum working pressure of the cylinders, even temporarily.
- j) When the cylinders have been filled correctly and the process is completed, immediately remove the cylinders and the equipment from the site and close all isolation valves on the equipment.
- k) The recovered refrigerant should not be re-used in any other refrigeration system unless it has been cleaned and checked.

## NOTE

In case of any concern:

Contact the local dealer for further information about refrigerant removal, evacuation, charge, and recovery of the R290 refrigerant,

Contact the local dealer for further information about unit decommissioning.



## 17. TECHNICAL DATA

### 17.1 General

Model	1-phase		1-phase		1-phase			3-phase		
	4 kW	6 kW	8 kW	10 kW	12 kW	14 kW	16 kW	12 kW	14 kW	16 kW
Nominal capacity	Refer to the Technical Data									
Dimensions H×W×D	717 x 1 299 x 426 mm		865 x 1 385 x 523 mm		865 x 1 385 x 523 mm			865 x 1 385 x 523 mm		
Packing dimensions H×W×D	885 x 1 375 x 475 mm		1 035 x 1 465 x 560 mm		1 035 x 1 465 x 560 mm			1 035 x 1 465 x 560 mm		
Weight (without backup heater)										
Net weight	90 kg		117 kg		135 kg			137 kg		
Gross weight	110 kg		139 kg		157 kg			159 kg		
Weight (with backup heater)										
Net weight	95 kg		122 kg		140 kg			142 kg		
Gross weight	115 kg		144 kg		162 kg			164 kg		
Connections										
Water inlet/outlet	G1"BSP		G1 1/4"BSP							
Water drain	Hose nipple									
Expansion vessel										
Volume	8 L									
Maximum working pressure (MWP)	8 bar									
Pump										
Type	Water cooled									
No. of speed	Variable speed									
Pressure relief valve in water loop	0.3 MPa(3 bar)									
Operation range - water side										
Heating	Maximum 75 °C									
Cooling	Minimum 25 °C									
Operation range - air side										
Heating	-25 °C to 35 °C									
Cooling	-5 °C to 46 °C									
Domestic hot water by heat pump	-25 °C to 46 °C									

Refrigerant				
Refrigerant type	R290			
Refrigerant charge	0.7 kg	1.1 kg	1.25 kg	1.25 kg

Fuse – on PCB		
PCB name	Main control board	Inverter module
Model name	FUSE-T-10A/250VAC-T-P	FUSE-T-30A/250VAC-T-P-HT
Working voltage (V)	250	
Working current (A)	10	30

Water flow switch		
Model	4/6/8/10 kW	12/14/16 kW
Set point	0.36 m <sup>3</sup> /h ± 0.06	0.6 m <sup>3</sup> /h ± 0.06

## 17.2 Electrical Specifications

Model		1-phase 4/6/8/10/12/14/16 kW	3-phase 12/14/16 kW
Standard unit	Power Supply	See " 7.4.1 Field wiring guidelines"	
	Nominal Running Current		
Backup heater	Power Supply		
	Nominal Running Current		

## 17.3 Piping diagram

4-6 kW units (standard)

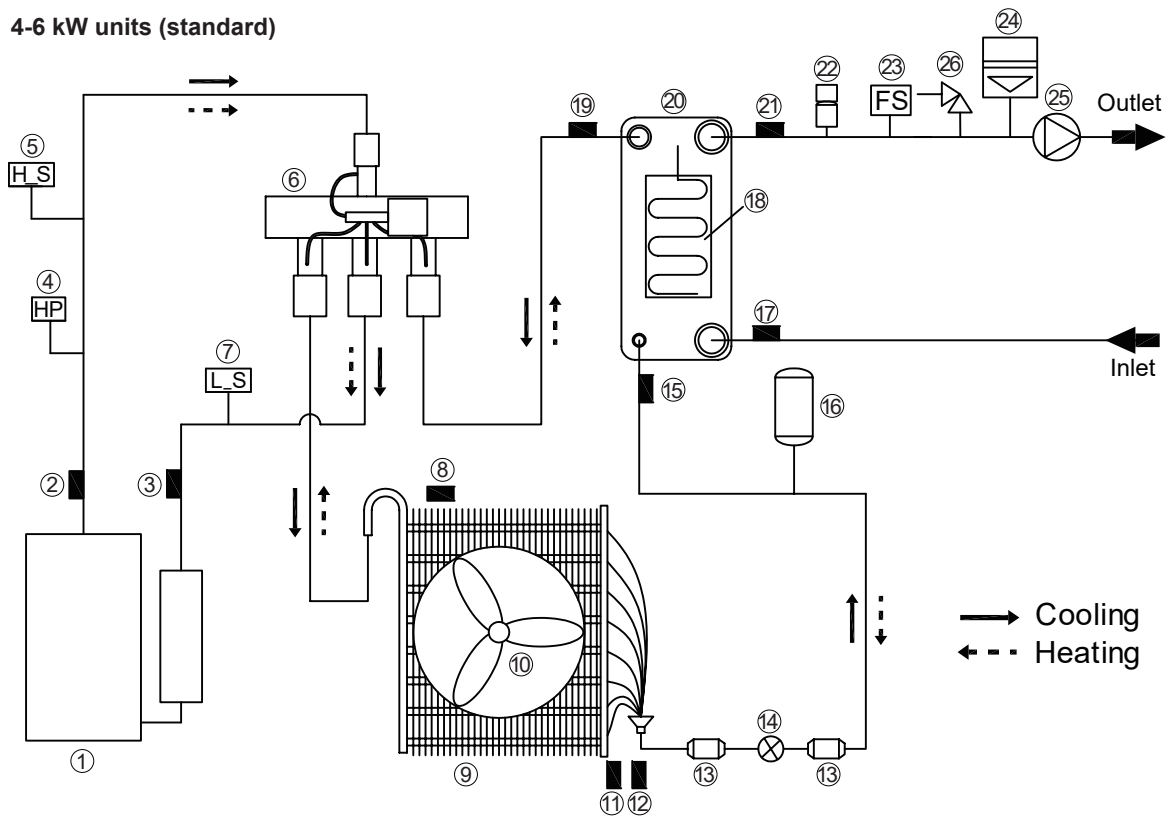

Item	Description	Item	Description
1	Compressor	14	Electronic expansion valve
2	Temperature sensor (compressor discharge)	15	Temperature sensor (plate heat exchanger inlet refrigerant: cooling)
3	Temperature sensor (compressor suction)	16	Liquid reservoir
4	High pressure switch	17	Temperature sensor (water inlet)
5	High pressure sensor	18	Heat tape (plate heat exchanger)
6	4-way valve	19	Temperature sensor (plate heat exchanger outlet refrigerant: cooling)
7	Low pressure sensor	20	Plate heat exchanger
8	Temperature sensor (outdoor air)	21	Temperature sensor ( water outlet)
9	Heat exchanger	22	Automatic air vent valve
10	Fan	23	Water flow switch
11	Temperature sensor (heat exchanger)	24	Expansion vessel
12	Temperature sensor (heat exchanger outlet refrigerant: cooling)	25	Water pump
13	Filter	26	Pressure relief valve

8-16 kW units (standard)

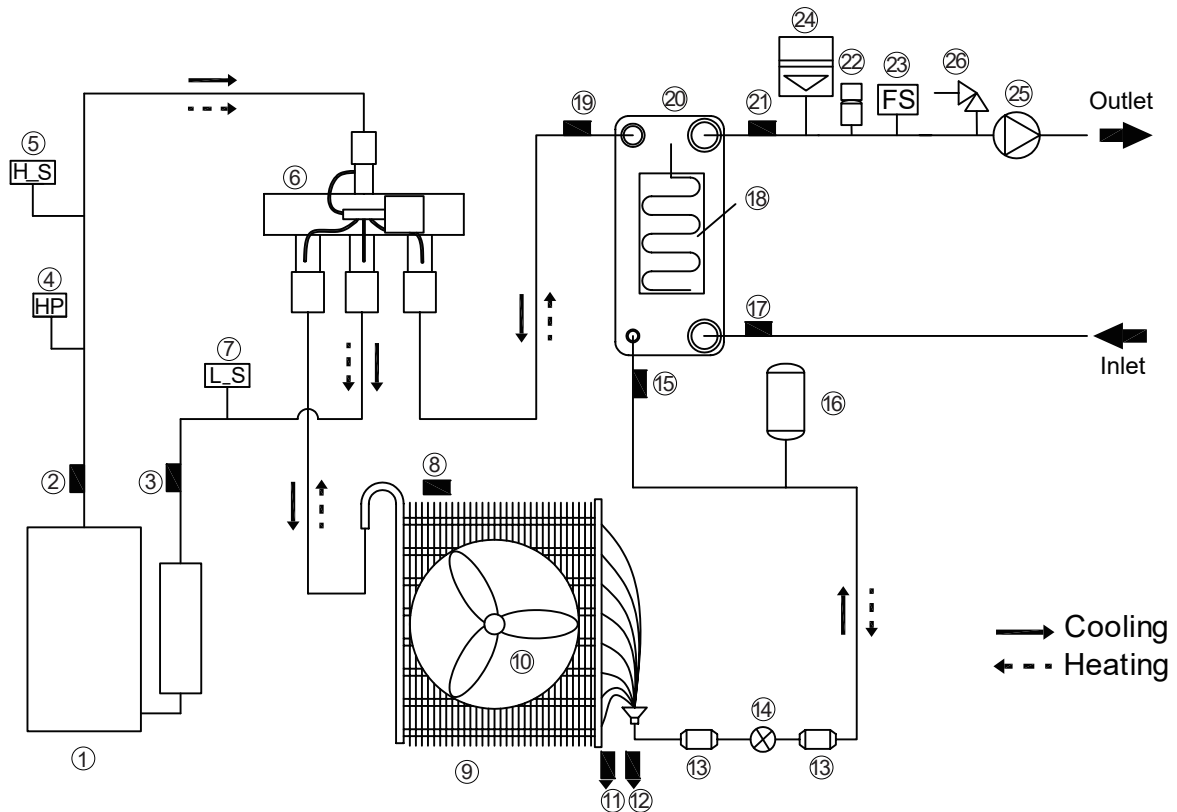

Item	Description	Item	Description
1	Compressor	14	Electronic expansion valve
2	Temperature sensor (compressor discharge)	15	Temperature sensor (plate heat exchanger inlet refrigerant: cooling)
3	Temperature sensor (compressor suction)	16	Liquid reservoir
4	High pressure switch	17	Temperature sensor (water inlet)
5	High pressure sensor	18	Heat tape (plate heat exchanger)
6	4-way valve	19	Temperature sensor (plate heat exchanger outlet refrigerant: cooling)
7	Low pressure sensor	20	Plate heat exchanger
8	Temperature sensor (outdoor air)	21	Temperature sensor (water outlet)
9	Heat exchanger	22	Automatic air vent valve
10	Fan	23	Water flow switch
11	Temperature sensor (heat exchanger)	24	Expansion vessel
12	Temperature sensor (heat exchanger outlet refrigerant: cooling)	25	Water pump
13	Filter	26	Pressure relief valve

### 4-16 kW (With IBH)

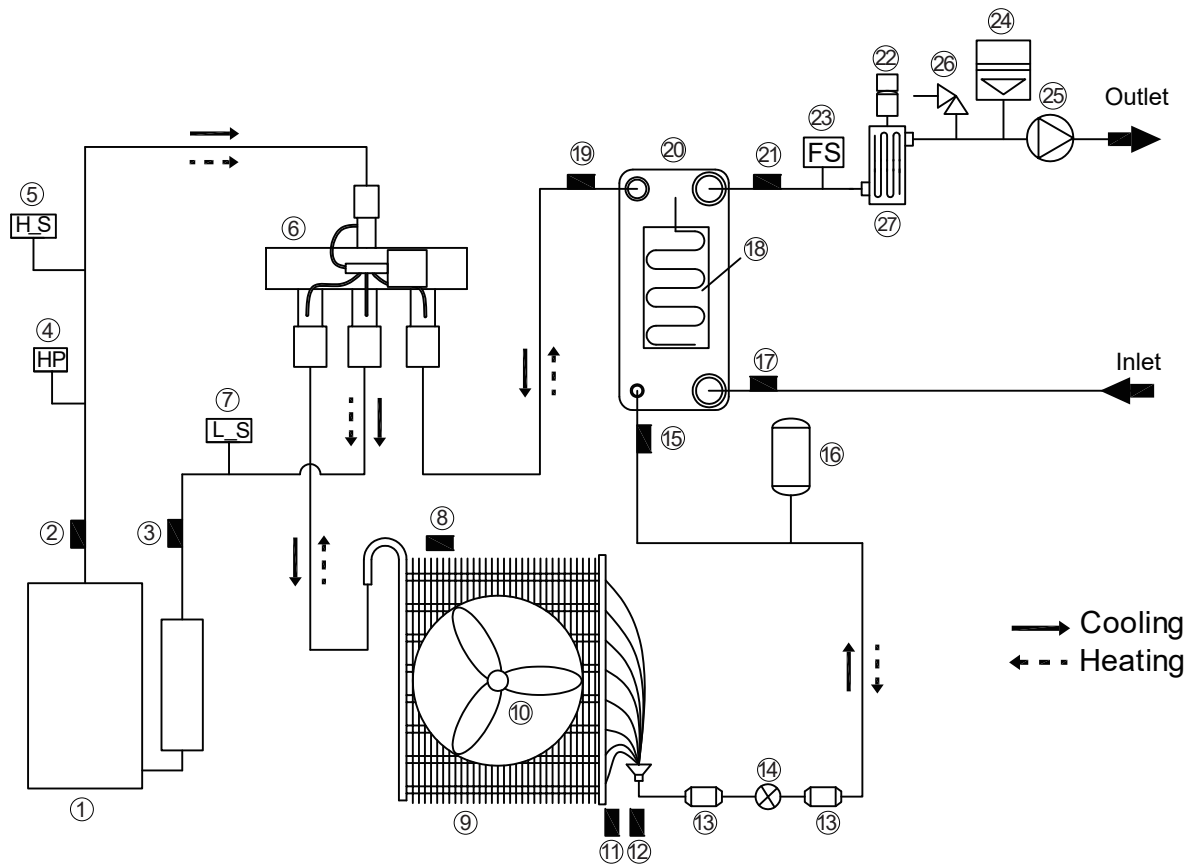

Item	Description	Item	Description
1	Compressor	14	Electronic expansion valve
2	Temperature sensor (compressor discharge)	15	Temperature sensor (plate heat exchanger inlet refrigerant: cooling)
3	Temperature sensor (compressor suction)	16	Liquid reservoir
4	High pressure switch	17	Temperature sensor (water inlet)
5	High pressure sensor	18	Heat tape (plate heat exchanger)
6	4-way valve	19	Temperature sensor (plate heat exchanger outlet refrigerant: cooling)
7	Low pressure sensor	20	Plate heat exchanger
8	Temperature sensor (outdoor air)	21	Temperature sensor (water outlet)
9	Heat exchanger	22	Automatic air vent valve
10	Fan	23	Water flow switch
11	Temperature sensor (heat exchanger)	24	Expansion vessel
12	Temperature sensor (heat exchanger outlet refrigerant: cooling)	25	Water pump
13	Filter	26	Pressure relief valve
		27	Backup heater (optional)

# ANNEX

## Annex A. Menu structure (wired controller)

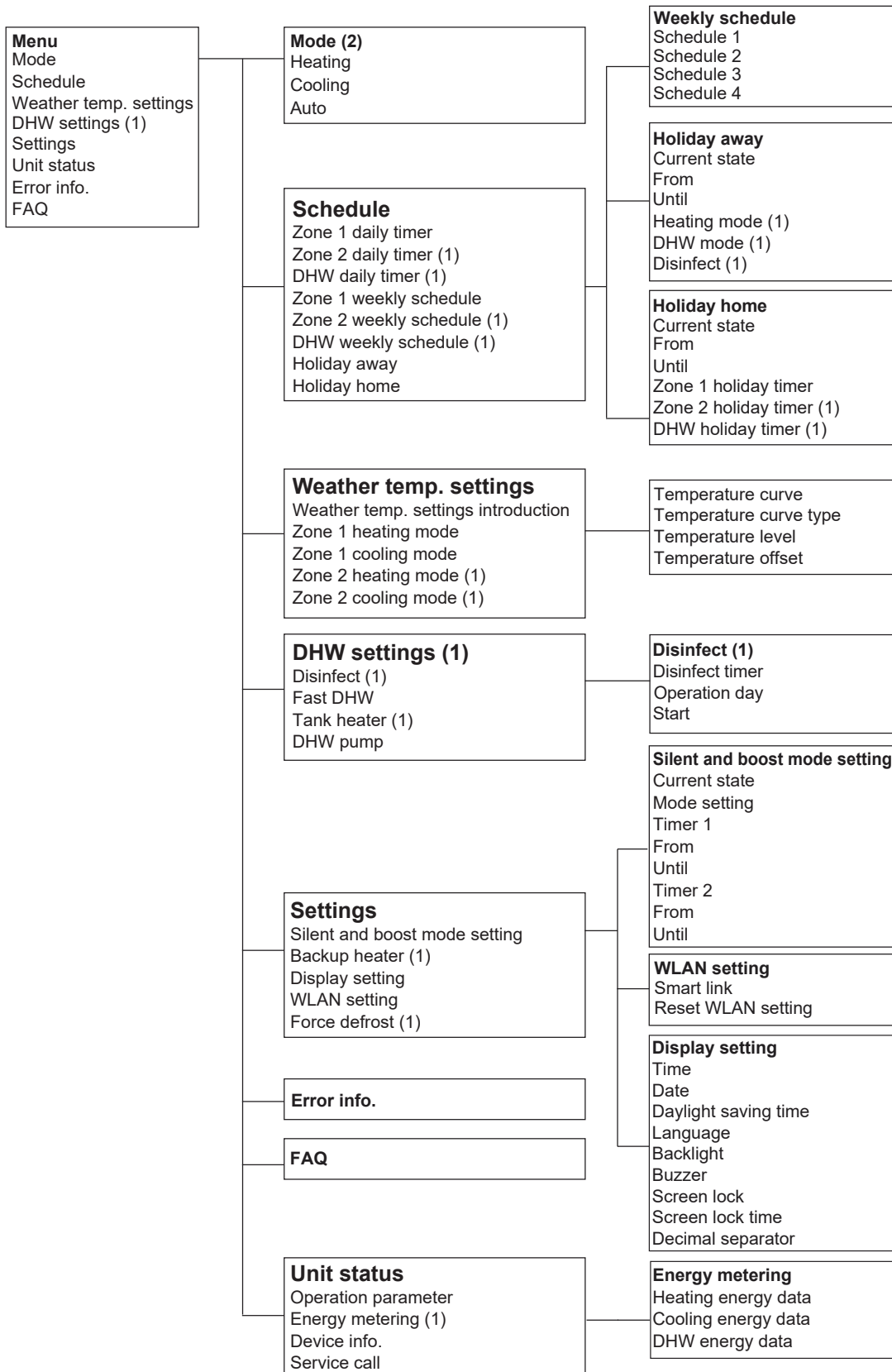

(1) Invisible if corresponding function is disabled.

(2) The layout could be different if the corresponding function is disabled or enabled.

There are also some other items that are invisible if the function is disabled or unavailable.

For serviceman

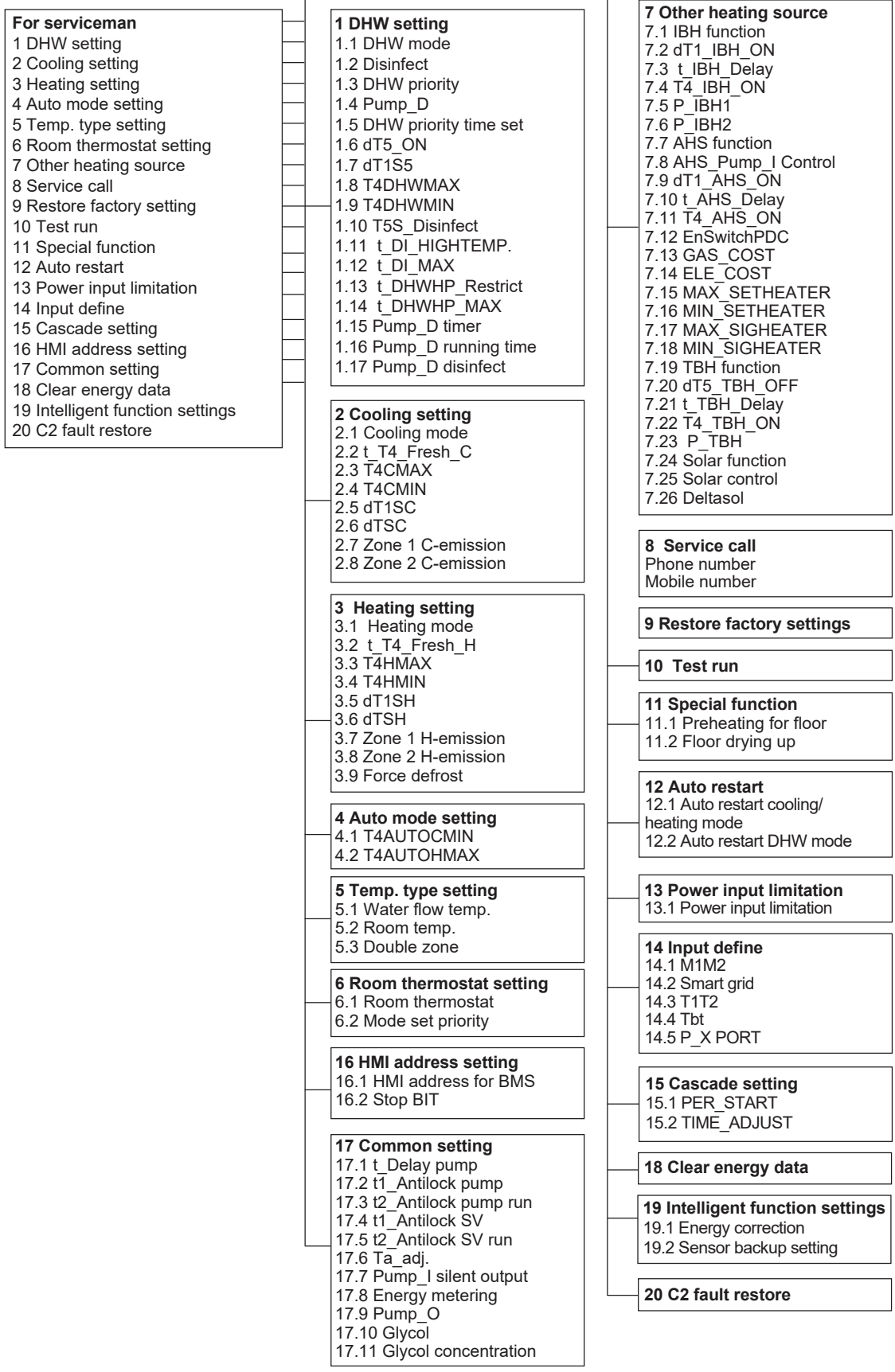

There are some items that are invisible if the function is disabled or unavailable.

## Annex B. User settings parameters

No.	Code	Definition	Default	Minimum	Maximum	Setting interval	Unit	
6.1 Mode & Temperature set								
Mode	Operation mode	Operation mode setting 1=Auto, 2=Cooling, 3=Heating	3	1	3	/	/	
Temperature set	T1S	Water outlet temperature (Zone 1)	For FCU cooling	12	5	25	1	°C
			For FLH / RAD cooling	23	18	25	1	°C
			For FLH heating	30	25	55	1	°C
			For FCU / RAD heating	40	35	80	1	°C
	T1S2	Water outlet set temperature (Zone 2)	For FCU cooling	12	5	25	1	°C
			For FLH / RAD cooling	23	18	25	1	°C
			For FLH heating	30	25	55	1	°C
			For FCU / RAD heating	40	35	80	1	°C
	TS	Room set temperature Ta	Cooling	24	17	30	0.5	°C
			Heating	24	17	30	0.5	°C
AUTO			24	17	30	0.5	°C	
T5S (DHW MODE=Yes)	DHW set temperature	50	20	70	1	°C		
6.2 Schedule								
Zone 1 daily timer	TIMER1-TIMER6	Enablement 0=inactive, 1=active	0	0	1	1	/	
	TIMER1-TIMER6 Time	Timer start time	00:00	00:00	23:50	1/10	h/min	
	TIMER1-TIMER6 Mode	Operation mode of the timer 2=Cooling, 1=Heating, 0=OFF	0	0	2	1	/	
	TIMER1-TIMER6 Temp.	Set temperature of the timer	For FCU cooling	12	5	25	1	°C
			For FLH / RAD cooling	23	18	25	1	°C
			For FLH heating	30	25	55	1	°C
			For FCU / RAD heating	40	35	80	1	°C
			Room heating set temperature Ta	24	17	30	0.5	°C
	Room cooling set temperature Ta	24	17	30	0.5	°C		
	Zone 2 daily timer	TIMER1-TIMER6	Enablement 0=inactive, 1=active	0	0	1	1	/
TIMER1-TIMER6 Time		Timer start time	00:00	00:00	23:50	1/10	h/min	
TIMER1-TIMER6 Mode		Operation mode of the timer 2=Cooling, 1=Heating, 0=OFF	0	0	2	1	/	
TIMER1-TIMER6 Temp.		Set temperature of the timer	For FCU cooling	12	5	25	1	°C
			For FLH / RAD cooling	23	18	25	1	°C
			For FLH heating	30	25	55	1	°C
			For FCU / RAD heating	40	35	80	1	°C
			Room heating set temperature Ta	24	17	30	0.5	°C
Room cooling set temperature Ta		24	17	30	0.5	°C		
DHW daily timer		TIMER1-TIMER6	Enablement 0=inactive, 1=active	0	0	1	1	/
	TIMER1-TIMER6 Time	Timer start time	00:00	00:00	23:50	1/10	h/min	
	TIMER1-TIMER6 DHW	Operation mode of the timer 1=DHW 0=OFF	0	0	1	1	/	
	TIMER1-TIMER6 Temp.	Set temperature of the timer	50	20	70	1	/	
Zone 1 weekly schedule	Schedule1 - Schedule4	Enablement 0=inactive, 1=active	0	0	1	1	/	
	Schedule1 - Schedule4 Day	Enablement 0=inactive, 1=active (if all the date is active, then display 'Every day')	0	0	1	1	/	
	Command1-Command4	Enablement	0	0	1	1	/	
	Command1-Command4 Time	Timer start time	00:00	00:00	23:50	1/10	h/min	
	Command1-Command4 Mode	Operation mode of the timer 2=Cooling, 1=Heating, 0=OFF	0	0	2	1	/	
	Command1-Command4 Temp.	Set temperature of the timer	For FCU cooling	12	5	25	1	°C
			For FLH / RAD cooling	23	18	25	1	°C
			For FLH heating	30	25	55	1	°C
For FCU / RAD heating	40	35	80	1	°C			
Room heating set temperature Ta	24	17	30	0.5	°C			
Room cooling set temperature Ta	24	17	30	0.5	°C			

Zone 2 weekly schedule	Schedule1 - Schedule4	Enablement 0=inactive, 1=active	0	0	1	1	/	
	Schedule1 - Schedule4 Day Sunday / Monday / Tuesday / Wednesday / Thursday / Friday / Saturday	Enablement 0=inactive, 1=active (if all the date is active, then display 'Every day')	0	0	1	1	/	
	Command1-Command4	Enablement 0=inactive, 1=active	0	0	1	1	/	
	Command1-Command4 Time	Timer start time	00:00	00:00	23:50	1/10	h/min	
	Command1-Command4 Mode	Operation mode of the timer 2=Cooling, 1=Heating, 0=OFF	0	0	2	1	/	
	Command1-Command4 Temp.	Set temperature of the timer	For FCU cooling	12	5	25	1	°C
			For FLH / RAD cooling	23	18	25	1	°C
For FLH heating			30	25	55	1	°C	
For FCU / RAD heating			40	35	80	1	°C	
Room heating set temperature Ta			24	17	30	0.5	°C	
		Room cooling set temperature Ta	24	17	30	0.5	°C	
DHW weekly schedule	Schedule1 - Schedule4	Enablement 0=inactive, 1=active	0	0	1	1	/	
	Schedule1 - Schedule4 Day Sunday / Monday / Tuesday / Wednesday / Thursday / Friday / Saturday	Enablement 0=inactive, 1=active (if all the date is active, then display 'Every day')	0	0	1	1	/	
	Command1-Command4	Enablement 0=inactive, 1=active	0	0	1	1	/	
	Command1-Command4 Time	Timer start time	00:00	00:00	23:50	1/10	h/min	
	Command1-Command4 DHW	Operation mode of the timer 2=Cooling, 1=Heating, 0=OFF	0	0	1	1	/	
	Command1-Command4 Temp.	Set temperature of the timer	50	20	70	1	/	
Holiday away	Current state	Enablement 0=inactive, 1=active	0	0	1	1	/	
	From	Timer start date	Current date +1	Current date +1	12/31/2099	1/1/1	d/m/y	
	Until	Timer end date	Current date +1	Current date +1	12/31/2099	1/1/1	d/m/y	
	Heating mode	Enablement 0=inactive, 1=active	1	0	1	1	/	
	Heating temp.	Set temperature of Holiday away	25	20	25	1	°C	
	DHW mode	Enablement 0=inactive, 1=active	1	0	1	1	/	
	DHW temp.	Set temperature of Holiday away	25	20	25	1	°C	
	Disinfect	Enablement 0=inactive, 1=active	1	0	1	1	/	
Holiday home	Current state	Enablement 0=inactive, 1=active	0	0	1	1	/	
	From	Timer start date	Current date +1	Current date +1	12/31/2099	1/1/1	d/m/y	
	Until	Timer end date	Current date +1	Current date +1	12/31/2099	1/1/1	d/m/y	
	Zone 1 holiday timer -timer1-timer6	Enablement 0=inactive, 1=active	0	0	1	1	/	
	Zone 1 holiday timer -timer1-timer6 Time	Timer start time	00:00	00:00	23:50	1/10	h/min	
	Zone 1 holiday timer -timer1-timer6 Mode	Operation mode of the timer 2=Cooling, 1=Heating, 0=OFF	0	0	2	1	/	
	Zone 1 holiday timer -timer1-timer6 Temp.	Set temperature of the timer	For FCU cooling	12	5	25	1	°C
			For FLH / RAD cooling	23	18	25	1	°C
			For FLH heating	30	25	55	1	°C
			For FCU / RAD heating	40	35	80	1	°C
			Room heating set temperature Ta	24	17	30	0.5	°C
			Room cooling set temperature Ta	24	17	30	0.5	°C
	Zone 2 holiday timer -timer1-timer6	Enablement 0=inactive, 1=active	0	0	1	1	/	
Zone 2 holiday timer -timer1-timer6 Time	Timer start time	00:00	00:00	23:50	1/10	h/min		
Zone 2 holiday timer -timer1-timer6 Mode	Operation mode of the timer 2=Cooling, 1=Heating, 0=OFF	0	0	2	1	/		



	Zone 2 holiday timer -timer1-timer6 Temp.	Set temperature of the timer	For FCU cooling	12	5	25	1	°C
			For FLH / RAD cooling	23	18	25	1	°C
			For FLH heating	30	25	55	1	°C
			For FCU / RAD heating	40	35	80	1	°C
			Room heating set temperature Ta	24	17	30	0.5	°C
			Room cooling set temperature Ta	24	17	30	0.5	°C
DHW holiday timer -timer1-timer6	Enablement 0=inactive, 1=active		0	0	1	1	/	
DHW holiday timer -timer1-timer6 Time	Timer start time		00:00	00:00	23:50	1/10	h/min	
DHW holiday timer -timer1-timer6 Mode	Operation mode of the timer 2=Cooling, 1=Heating, 0=OFF		0	0	1	1	/	
DHW holiday timer -timer1-timer6 Temp.	Set temperature of the timer		50	20	70	1	/	
6.3 Weather temp. settings								
Zone 1 heating mode	Temperature curve	Enablement 0=inactive, 1=active		0	0	1	1	/
	Temperature curve type	Temperature curve type 0=Standard, 1=Custom, 2=ECO		0	0	2	1	/
	Standard - Temperature level	Curve for FCU / RAD heating		6	1	8	1	/
		Curve for FLH heating		3	1	8	1	/
	Standard - Temperature offset	Zone 1 heating set temperature offset of curve		0	-10	25	1	°C
	Custom - Temperature setting - T1SetH1	Heating set temperature 1 of curve		35	25	80	1	°C
	Custom - Temperature setting - T1SetH2	Heating set temperature 2 of curve		28	25	80	1	°C
	Custom - Temperature setting - T4H1	Heating ambient temperature 1 of curve		-5	-25	35	1	°C
	Custom - Temperature setting - T4H2	Heating ambient temperature 2 of curve		7	-25	35	1	°C
	ECO - Temperature level	Curve for FLH heating		3	1	8	1	/
		Curve for FCU / RAD heating		6	1	8	1	/
	ECO timer	Enablement 0=inactive, 1=active		0	0	1	1	/
From	Timer start date		8:00	00:00	23:50	1/10	h/min	
Until	Timer end date		19:00	00:00	23:50	1/10	h/min	
Zone 1 cooling mode	Temperature curve	Enablement 0=inactive, 1=active		0	0	1	1	/
	Temperature curve type	Temperature curve type 0=Standard, 1=Custom		0	0	1	1	/
	Standard - Temperature level	Curve for FLH / RAD cooling		4	1	8	1	/
		Curve for FCU cooling		4	1	8	1	/
	Standard - Temperature offset	Zone 1 cooling set temperature offset of curve		0	-10	10	1	°C
	Custom - Temperature setting - T1SetC1	Cooling set temperature 1 of curve		10	5	25	1	°C
	Custom - Temperature setting - T1SetC2	Cooling set temperature 2 of curve		16	5	25	1	°C
	Custom - Temperature setting - T4C1	Cooling ambient temperature 1 of curve		35	-5	46	1	°C
Custom - Temperature setting - T4C2	Cooling ambient temperature 2 of curve		25	-5	46	1	°C	
Zone 2 heating mode	Temperature curve	Enablement 0=inactive, 1=active		0	0	1	1	/
	Temperature curve type	Temperature curve type 0=Standard, 1=Custom		0	0	1	1	/
	Standard - Temperature level	Curve for FCU / RAD heating		6	1	8	1	/
		Curve for FLH heating		3	1	8	1	/
	Standard - Temperature offset	Zone 2 heating set temperature offset of curve		0	-10	25	1	°C
	Custom - Temperature setting - T1SetH1	Heating set temperature 1 of curve		35	25	80	1	°C
	Custom - Temperature setting - T1SetH2	Heating set temperature 2 of curve		28	25	80	1	°C
	Custom - Temperature setting - T4H1	Heating ambient temperature 1 of curve		-5	-25	35	1	°C
Custom - Temperature setting - T4H2	Heating ambient temperature 2 of curve		7	-25	35	1	°C	

Zone 2 cooling mode	Temperature curve	Enablement 0=inactive, 1=active	0	0	1	1	/
	Temperature curve type	Temperature curve type 0=Standard, 1=Custom	0	0	1	1	/
	Standard - Temperature level	Curve for FLH / RAD cooling	4	1	8	1	/
		Curve for FCU cooling	4	1	8	1	/
	Standard - Temperature offset	Zone 2 cooling set temperature offset of curve	0	-10	10	1	°C
	Custom - Temperature setting - T1SetC1	Cooling set temperature 1 of curve	10	5	25	1	°C
	Custom - Temperature setting - T1SetC2	Cooling set temperature 2 of curve	16	5	25	1	°C
	Custom - Temperature setting - T4C1	Cooling ambient temperature 1 of curve	35	-5	46	1	°C
Custom - Temperature setting - T4C2	Cooling ambient temperature 2 of curve	25	-5	46	1	°C	
6.4 DHW settings							
Disinfect	Current state	State OFF=0, ON=1	1	0	1	1	/
	Operation day Sunday / Monday / Tuesday / Wednesday / Thursday / Friday / Saturday	Enablement 0=inactive, 1=active (if all the date is active, then display 'Every day')	Thurs- day = 1, other=0	0	1	1	/
	Start	Start time	23:00	00:00	23:50	1/10	h/min
Fast DHW	Fast DHW	State OFF=0, ON=1	0	0	1	1	/
Tank heater	Tank heater	State OFF=0, ON=1	0	0	1	1	/
DHW pump	DHW pump timer 1-12	State OFF=0, ON=1	0	0	1	1	/
	DHW pump timer 1-12 time	Start time	00:00	00:00	23:50	1/10	h/min
6.5 Settings							
Silent mode	Silent and boost mode setting	Enablement OFF=0, ON=1	0	0	1	1	/
	Mode setting	0=Silent 1=Super silent,2=Boost	0	0	1	1	/
	Timer 1	Enablement 0=inactive, 1=active	0	0	1	1	/
	From	Start time 1	12:00	00:00	23:50	1/10	h/min
	Until	End time 1	15:00	00:00	23:50	1/10	h/min
	Timer 2	Enablement 0=inactive, 1=active	0	0	1	1	/
	From	Start time 2	22:00	00:00	23:50	1/10	h/min
Until	End time 2	07:00	00:00	23:50	1/10	h/min	
Backup heater	Backup heater	Enablement 0=OFF, 1=ON	0	0	1	1	/
Display setting	Time	Current time	00:00	00:00	23:59	1/1	h/min
	Date	Current date	1/1/2023	1/1/2023	12/31/2099	1	/
	Daylight saving time	Daylight saving time setting, 0=OFF, 1=ON	0	0	1	1	/
	Start time	Daylight saving time start time	00:00	00:00	23:59	1/1	h/min
	Start date	Daylight saving time start date	1/3	1/3	30/4	1/1	d/m
	End time	Daylight saving time end time	00:00	00:00	23:59	1/1	h/min
	End date	Daylight saving time end date	15/9	15/9	15/11	1/1	d/m
	Language	0=English, 1=Français, 2=Italiano, 3=Español, 4=Polski, 5=Português, 6=Deutsch, 7=Nederlands, 8=Română, 9=Русский, 10=Türkçe, 11=Ελληνικά, 12=Slovenščina, 13=Svenska, 14=Čeština, 15=Slovák, 16=Magyar, 17=Hrvatski, 18=Dansk, 19=українська, 20=Suomalainen	0	0	17	1	/
	Backlight	Backlight level	2	1	3	1	/
	Buzzer	Enablement, 0 = inactive, 1 = active	1	0	1	1	/
	Screen lock time	lock timer	0	0	300	30	Second
Decimal separator	Decimal separator setting ,0= Comma, 1=Period	0	0	1	1	/	
Force defrost	Force defrost	Enablement 0=OFF, 1=ON	0	0	1	1	/

## Annex C. Modbus mapping table

### 1) MODBUS PORT COMMUNICATION SPECIFICATIONS

Port: RS-485; H1 and H2 are the Modbus communication ports.

Communication address: Only one-to-one connection is available for the host computer and wired controller, and the wired controller is a slave unit. The communication address of the host computer and wired controller is consistent with the address of 17.2 HMI Address for BMS (In FOR SERVICEMAN mode).

Baud rate: 9600. Number of digits: 8 Verification: none. Stop bit: 1 bit

Communication protocol: Modbus RTU (Modbus ASCII not supported)



### 2) Mapping of registers in the wired controller

Please download the file via QR code.





## Annex D. Available accessories

### Balance tank temperature sensor

Thermistor for balance tank(Tbt1)		1
Extension wire for Tbt1		1



Refer to 3.8 Temperature Sensor for the resistance characteristics of the temperature sensor.

### Zone 2 flow temperature sensor

Thermistor for Zone 2 flow temp.(Tw2)		1
Extension wire for Tw2		1

Refer to 3.8 Temperature Sensor for the resistance characteristics of the temperature sensor.

### Solar temperature sensor

Thermistor for solar temp.(Tsolar)		1
Extension wire for Tsolar		1

Refer to 3.8 Temperature Sensor for the resistance characteristics of the temperature sensor.

### NOTE

Tbt1, Tw2, and Tsolar can share the same temperature sensor and extension wire If necessary. The standard length of the sensor cable is 10 meters. If an additional length is required, please make a specific order for the extended length.

## Annex E. Terms and abbreviation

Tp	Compressor discharge temperature
Th	Compressor Suction temperature
T4	Outdoor air temperature
T3	Heat exchanger temperature
TL	Heat exchanger outlet refrigerant(cooling) temperature
T2	Plate heat exchanger inlet refrigerant(cooling) temperature
T2B	Plate heat exchanger outlet refrigerant(cooling) temperature
Tw_in	Inlet water temperature
Tw_out	Outlet water temperature
T5	DHW tank temperature
Tw2	Zone 2 water temperature
Tbt	Balance tank temperature
T1	IBH/AHS outlet water temperature
Ta	Indoor ambient temperature
SV	3-way valves
Pump_I	Integrated circulation pump
P_c (Pump_C)	Zone 2 pump
P_o (Pump_O)	Additional circulation pump(for Zone 1)
P_s (Pump_S)	Solar heating loop circulation pump
P_d (Pump_D)	DHW pump
AHS	Additional heat source
IBH	Internal backup heater
TBH	Tank booster heater
SG	SG-ready signal 1
EVU	SG-ready signal 2
HMI	Human-machine interface (wired controller)

### Bottom plate heating tape

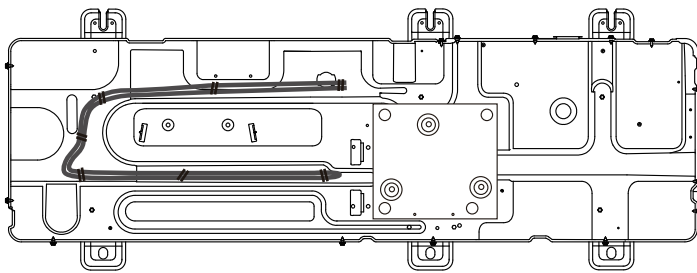

EM23IU-034C-EN



Kaysun  
by frigicoll

MAIN OFFICE

Blasco de Garay, 4-6  
08960 Sant Just Desvern  
(Barcelona)  
Tel. +34 93 480 33 22  
<http://www.frigicoll.es/>  
<http://www.kaysun.es/en/>

MADRID

Senda Galiana, 1  
Poligono Industrial Coslada  
Coslada (Madrid)  
Tel. +34 91 669 97 01  
Fax. +34 91 674 21 00  
[madrid@frigicoll.es](mailto:madrid@frigicoll.es)