

ORIGINAL
MANUAL

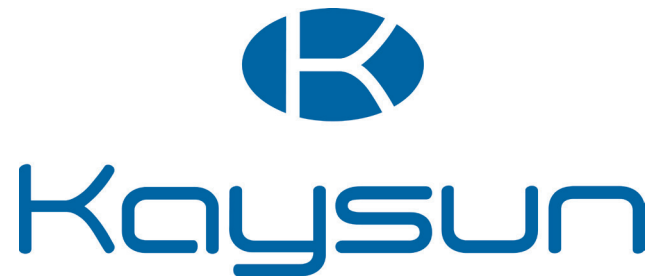

INSTALLATION MANUAL

Aquantia KHP-MO HT HP

KHP-MO 26 DTP

KHP-MO 30 DTP

KHP-MO 35 DTP



Please read this manual carefully and keep it for future reference.
All the pictures in this manual are for illustrations purpose only.

CONTENTS

1 SAFETY PRECAUTIONS	01
2 GENERAL INTRODUCTION	07
• 2.1 Documentation.....	07
• 2.2 Validity of the Instructions	07
• 2.3 Unpacking	08
• 2.4 Accessories of the Unit	08
• 2.5 Transportation.....	09
• 2.6 About the Unit.....	10
3 SYSTEM DESIGN	13
4 UNIT INSTALLATION	14
5 UNIT INSTALLATION	15
• 5.1 General Rules.....	15
• 5.2 Installation Site	15
• 5.3 Foundation and Unit Installation	16
• 5.4 Drainage	16
• 5.5 In Cold Climates	18
• 5.6 Exposure to Strong Sunlight	18
6 HYDRAULIC INSTALLATION	18
• 6.1 Preparations for Installation	18
• 6.2 Water Loop Connection	18
• 6.3 Water	19
• 6.4 Filling Water Loop with Water	20
• 6.5 Filling Domestic Hot Water Tank with Water	20
• 6.6 Water Pipe Insulation	20
• 6.7 Freeze Protection	21
• 6.8 Check of Water Loop	22
7 ELECTRICAL INSTALLATION	23
• 7.1 Opening the Electrical Box Cover	23
• 7.2 Back plate layout for wiring	23
• 7.3 Electrical Wiring Guidelines	24
• 7.4 Connection with Power Supply	25
• 7.5 Connection of Other Components	25
• 7.6 Cascade Function	32
• 7.7 Connection for Other Optional Components	32
8 INSTALLATION OF WIRED CONTROLLER	33
• 8.1 Materials for Installation	33
• 8.2 Dimensions	33

• 8.3 Wiring	33
• 8.4 Mounting	34
9 COMPLETION OF INSTALLATION.....	36
10 CONFIGURATION	36
• 10.1 Check Before Configuration	36
• 10.2 Configuration	37
11 COMMISSIONING.....	38
• 11.1 Test Run for the Actuator	38
• 11.2 Air Purge	38
• 11.3 Test Run	39
• 11.4 Check of the Minimum Flow Rate	39
12 HAND-OVER TO THE USER.....	39
13 MAINTENANCE	40
• 13.1 Safety Precautions for Maintenance	40
• 13.2 Annual Maintenance	40
14 TECHNICAL DATA	41
• 14.1 General	41
• 14.2 Electrical Specifications	42
ANNEX	43
Annex 1. Menu Structure (Wired Controller)	43
Annex 2. User Settings Parameters	45
Annex 3. Terms and abbreviation	49

1 SAFETY PRECAUTIONS

Observe the basic safety regulations before starting work and operation.

DANGER

It indicates a hazard with a high level of risk which, if not avoided, will result in serious injury.

WARNING

It indicates a hazard with a medium level of risk which, if not avoided, could result in serious injury.



CAUTION

It indicates a hazard with a low level of risk which, if not avoided, could result in minor or moderate injury.

NOTE

Additional information.

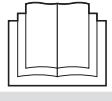
Symbols on the unit

	WARNING	Flammable refrigerant is applied. A fire may occur due to unexpected leakage of refrigerant.
	CAUTION	Read the operation manual carefully before any further action.
	CAUTION	Only a specialist is allowed to take action under the instructions of the installation manual.
	CAUTION	The information is available in the relevant documentation.

Target group

DANGER

These instructions are exclusively intended for qualified contractors and authorized installers.

- Work on the refrigerant circuit with flammable refrigerant in safety group A3 may only be carried out by authorized heating contractors. These heating contractors must be trained in accordance with EN 378 Part 4 or IEC 60335-2-40, Section HH. The certificate of competence from an industry accredited body is required.

- Brazing/soldering work on the refrigerant circuit may only be carried out by personnel certified in accordance with ISO 13585 and AD 2000, Datasheet HP 100R. And only contractors qualified and certified for the processes can perform brazing/soldering work. The work must fall within the range of applications purchased and be carried out in accordance with the prescribed procedures. Soldering/brazing work on accumulator connections requires certification of personnel and processes by a notified body according to the Pressure Equipment Directive (2014/68/EU).

- Work on electrical equipment may only be carried out by a qualified electrician.

- Before initial commissioning, all safety-related points must be checked by the particular certified heating contractors. The system must be commissioned by the system installer or a qualified person authorized by the installer.

Intended use

There is a risk of injury to the user or others, or of damage to the product and other property in the event of improper or unintended use.

The product is the outdoor unit of an air-to-water heat pump with monoblock design.

The product uses the outdoor air as a heat source and can be used to heat a residential building and generate domestic hot water.

The air that escapes from the product must be able to flow out freely, and must not be used for any other purposes.

The product is only intended for outdoor installation.

The product is intended exclusively for domestic use, which means that the following places are not appropriate for installation:

- Where there is mist of mineral oil or oil spray or vapors. Plastic parts may deteriorate, and cause joint loose and leakage of water.

- Where corrosive gases (such as sulfurous acid gas) are produced, or corrosion of copper pipes or soldered parts may cause leakage of refrigerant.

- Where there is machinery which emits massive electromagnetic waves. Enormous electromagnetic waves can disturb the control of the system and cause equipment malfunction.

- Where flammable gases may leak, carbon fiber or ignitable dust is suspended in the air or volatile flammables such as paint thinner or gasoline are handled. These types of gases might cause a fire.

- Where the air contains high levels of salt such as a location near the ocean.

- Where voltage fluctuates a lot, such as a location in a factory.

- In vehicles or vessels.

- Where acidic or alkaline vapors are present.

Intended use includes the following:

- Observance of the operating instructions included for the product and any other installation components.

- Compliance with all inspection and maintenance conditions listed in the instructions.

- Installing and setting up the product in accordance with the product and system approval.

- Installation, commissioning, inspection, maintenance and troubleshooting by qualified contractors and authorized installers.

Intended use also covers installation in accordance with the IP code.

This appliance can be used by children aged from 8 years and above and persons with reduced physical, sensory or mental capabilities or lack of experience and knowledge provided that they have been given supervision or instruction concerning the use of the appliance in a safe way and understand the hazards involved. Children should not play with the appliance. Cleaning and maintenance should not be made by children without supervision

Any other use that is not specified in these instructions, or use beyond that specified in this document, should be considered as improper use. Any direct commercial or industrial use is also deemed to be improper.

CAUTION

Improper use of any kind is prohibited.

- Do not rinse the unit.
- Do not place any object or equipment on top of the unit (top plate).
- Do not climb, sit or stand on top of the unit.

Regulations to be observed

- National installation regulations.
- Statutory regulations for the prevention of accidents.
- Statutory regulations for environmental protection.
- Statutory requirements for pressure equipment: Pressure Equipment Directive 2014/68/EU.
 - Codes of practice of the relevant trade associations.
 - Relevant country-specific safety regulations.
 - Applicable regulations and guidelines for operation, service, maintenance, repair and safety of cooling, air conditioning and heat pump systems containing flammable and explosive refrigerant.

Safety instructions for working on the system

The outdoor unit contains flammable refrigerant R290 (propane C3H8). In case of a leak, the escaping refrigerant may form a flammable or explosive atmosphere in the ambient air. A safety zone is defined in the immediate vicinity of the outdoor unit, in which special rules apply when work is performed on the appliance. See section "Safety zone".

Working in the safety zone

DANGER

Risk of explosion: Refrigerant leak may form a flammable or explosive atmosphere in the ambient air.

- Take the following measures to prevent fire and explosion in the safety zone:
 - Keep ignition sources away, including naked flames, plug sockets, hot surfaces, light switches, lamps, electrical devices not free of ignition sources, mobile devices with integrated batteries (such as mobile phones and fitness watches).
 - Do not use any sprays or other combustible gases in the safety zone.

CAUTION

Permissible tools: All tools for working in the safety zone must be designed and explosion-protected in accordance with the applicable standards and regulations for refrigerant in safety groups A2L and A3, such as brushless machines (cordless disposal containers, installation aids, and screwdrivers), extraction equipment, vacuum pumps, conductive hoses, and mechanical tools of non-sparking material.

CAUTION

The tools must also be suitable for the pressure ranges in use. Tools must be in perfect maintenance conditions.

- The electrical equipment must meet the requirements for areas at risk of explosion, zone 2.
- Do not use flammable materials such as sprays or other flammable gases.
- Before starting work, discharge static electricity by touching earthed objects, such as heating or water pipes.
- Do not remove, block or bridge safety equipment.
- Do not make any changes: Do not modify the outdoor unit, inlet/ outlet lines, electrical connections/ cables or the surroundings. Do not remove any components or seals.

Working on the system

Switch off the power supply for the unit (including all affiliated parts) at a separate fuse or mains isolator. Check and ensure that the system is no longer live.

CAUTION

In addition to the control circuit there may be several power circuits.

DANGER

Contact with live components can result in severe injuries. Some components on PCBs remain live even after the power supply has been switched off. Prior to removing covers from the appliances, wait at least 4 minutes until the voltage has completely dropped out.

- Safeguard the system against re-connection.
- Wear suitable personal protective equipment when carrying out any work.
- Do not touch any switch or electrical parts with wet fingers. It may cause electrical shock and compromise the system.

DANGER

Hot surfaces and fluids can result in burns or scalding. Cold surfaces may cause frostbite.

- Prior to servicing or maintenance tasks, switch off and allow the equipment to cool down or warm up.
- Do not touch hot or cold surfaces on the appliance, fittings or pipework.

NOTE

Electronic assemblies can be damaged by electrostatic discharge. Before beginning work, touch earthed objects, such as heating or water pipes, to discharge any static.

Safety work area and temporary flammability zones.

CAUTION

When working on systems using flammable refrigerants, the technician should consider certain locations as "temporary flammable zones". These are normally regions where at least some emission of refrigerant is anticipated to occur during the normal working procedures, such as recovery, charging and evacuation, typically where hoses may be connected or disconnected. The technician should ensure three meters safety working area (radius of the unit) in case of any accidental release of refrigerant that forms a flammable mixture with air.

Working on the refrigerant circuit

R290 refrigerant (propane) is an air displacing, colorless, flammable, odorless gas which forms explosive mixtures with air. Refrigerant drained must be properly disposed of by authorized contractors.

- Perform the following measures before beginning work on the refrigerant circuit:
 - Check the refrigerant circuit for leaks.
 - Ensure very good ventilation especially in the floor area and maintain this for the duration of the work.
 - Secure the area surrounding the work area.

- Inform the following persons of the type of work to be carried out: – All maintenance personnel – All persons in the vicinity of the system.

- Inspect the area immediately around the heat pump for flammable materials and ignition sources: Remove all flammable materials and ignition sources.

- Before, during and after the work, check the surrounding area for escaping refrigerant using an explosion-proof refrigerant detector suitable for R290. This refrigerant detector must not generate any sparks and must be suitably sealed.

- A CO₂ or powder extinguisher must be available in the following cases: – Refrigerant is being drained. – Refrigerant is being topped up. – Soldering or welding work is in progress.

- Display signs prohibiting smoking.

DANGER

Escaping refrigerant can lead to fires and explosions that result in very serious injuries.

- Do not drill or apply heat to a refrigerant circuit filled with refrigerant.
- Do not operate Schrader valves unless a fill valve or extraction equipment is attached.
- Take measures to prevent electrostatic charge.
- Do not smoke. Avoid naked flames and sparks. Never switch lights or electrical appliances on or off in environments with naked flames or sparks.
- Components that contain or contained refrigerant must be labeled, and stored in well ventilated areas in accordance with the applicable regulations and standards.

DANGER

Direct contact with liquid or gaseous refrigerant can cause serious damage to health such as frostbite and/or burns. There is a risk of asphyxiation if liquid or gaseous refrigerant is breathed in.

- Prevent direct contact with liquid or gaseous refrigerant.
- Wear personal protective equipment when handling liquid or gaseous refrigerant.
- Never breathe in any refrigerant vapor.

DANGER

Refrigerant is under pressure: Mechanical loading of lines and components can cause leaks in the refrigerant circuit. Do not apply loads to the lines or components, such as supporting or placing tools.

DANGER

Hot or cold metallic surfaces of the refrigerant circuit may cause burns or frostbite in case of skin contact. Wear personal protective equipment to protect against burns or frostbite.

NOTE

Hydraulic components may freeze during refrigerant removal. Drain heating water from the heat pump beforehand.

DANGER

Damage to the refrigerant circuit can cause refrigerant to enter the hydraulic system. After completion of the work, vent the hydraulic system correctly. When doing so, ensure the area is sufficiently ventilated.

Installation

General

Be sure to use only specified accessories and parts for installation. Failure to use specified parts may result in water leakage, electric shocks, fires, or the unit falling from its mount.

Install the unit on a foundation that can withstand its weight. Insufficient physical strength may cause the unit to fall and possible injury.

Perform specified installation work with full consideration of strong wind, hurricanes, or earthquakes. Improper installation may result in accidents due to equipment falling.

Earth the unit and install a ground fault circuit interrupter in accordance with local regulations. Operating the unit without a proper ground fault circuit interrupter may cause electric shocks and fires.

Install the power cable at least 3 feet (1 meter) away from televisions or radios to prevent interference or noise. (Depending on the radio waves, a distance of 3 feet (1 meter) may not be sufficient to eliminate the noise.)

Any damaged power cord must be replaced by the manufacturer or its service agent or a similarly qualified person in order to avoid a hazard.

CAUTION

Do not install any air vent valve in the indoor side. Make sure the outlet of the indoor safety valve leads to the outdoor side.

Two situations should be considered for outdoor installations to prevent damage to the system, releases, and undesirable consequences:

- Where the equipment is located in an area accessible by members of the public, and.
- Where the equipment is located in a restricted area, with access to authorized persons only.

DANGER



Open flames, fires, open ignition sources and smoking are prohibited.

DANGER



Inflammable matters are prohibited.

Frost protection

CAUTION

Freezing can cause damage to the heat pump.

- Thermally insulate all the hydraulic lines.
- Antifreeze can be filled in the secondary circuit in accordance with local regulations and standards.

Connecting cables

DANGER

With short electrical cables, should there be leakage in the refrigerant circuit, gaseous refrigerant may reach the inside of the building. Min. length of the electrical connecting cables between the indoor and the outdoor unit: 3 m.

Repair work

CAUTION

Repairing components that fulfil a safety function can compromise the safe operation of the system.

- Replace faulty components only with genuine spare parts from the manufacturer.
- Do not undertake any repairs on the inverter. Replace the inverter if there is a defect.
- Repair work should not be performed in the field. Repair the unit in a specified location.

Auxiliary components, spare and wearing parts

CAUTION

Spare and wearing parts that have not been tested together with the system can compromise the function of the system. Installing non-authorized components and making non-approved modifications or conversions can compromise the safety and may invalidate our warranty. Only use original spare parts supplied or approved by the manufacturer for replacement.

Safety instructions for operating the system

What to do if refrigerant leaks

WARNING

To avoid potential risk from refrigerant leak, always keep 2 meters away from the unit, especially for kids, no matter the unit is in operation or not.

DANGER

Refrigerant leak can lead to fires and explosions that result in very serious injuries. Breathing in refrigerant may cause asphyxiation.

- Ensure very good ventilation especially in the floor area of the outdoor unit.
- Do not smoke. Avoid naked flames and sparks. Never switch lights or electrical appliances on or off in environments with naked flames or sparks.
- Evacuate any people from the dangerous zone.
- From a safe position, switch off the power supply for all system components.
- Remove ignition sources from the dangerous zone.
- The system user should know that no ignition source may be brought into the dangerous zone during the repair.
- Repair work must be carried out by an authorized contractor.
- Do not recommission the system until it is repaired.

CAUTION

Direct contact with liquid or gaseous refrigerant can cause serious damage to health, e.g. frostbite and/or burns. Breathing in liquid or gaseous refrigerant may cause asphyxiation.

- Prevent direct contact with liquid or gaseous refrigerant.
- Never breathe in refrigerant vapors.

What to do if water leaks

DANGER

If water leaks from the appliance, an electric shock may occur. Switch off the heating system at the external isolator (e.g. fuse box, domestic distribution board).

CAUTION

If water leaks from the appliance, scalding may occur. Never touch hot water.

What to do if the outdoor unit ices up

CAUTION

A build-up of ice in the condensate pan and in the fan area of the outdoor unit can cause damage to the equipment.

- Do not use mechanical items/aids to remove ice.
- Before using electrical heating appliances, check the refrigerant circuit for leaks with a suitable measuring device. The heating appliance should not be a source of ignition, and must meet the requirements of EN 60335-2-30.
- If ice regularly builds up on the outdoor unit (e.g. in areas where frost and heavy fog occur frequently), install a fan ring heater (accessory) that is suitable for refrigerant R290 and/or an electric ribbon heater in the condensate pan (accessory or factory-fitted device).

Safety instructions for storage of the outdoor unit

The outdoor unit is charged at the factory with refrigerant R290 (propane).

DANGER

Refrigerant leak can lead to fires and explosions that result in very serious injuries. Breathing in refrigerant may cause asphyxiation. Store the outdoor unit in the following conditions:

- An explosion prevention plan must be in place for storage.
- Ensure the storage location is well ventilated.
- Keep away from ignition sources (avoid exposure to heat and smoking).
- Temperature range for storage: -25 °C to 70 °C
- Only store the outdoor unit in its exfactory protective packaging.
- Protect the outdoor unit against damage.
- The maximum number of outdoor units that may be stored in one place is determined according to local conditions.

WARNING

A fire with R290 should only be fought with CO₂ or dry powder extinguishers.

About the refrigerant

WARNING

- The following applies to R290 refrigerant systems.
- Prior to work on systems containing flammable refrigerants, safety checks are necessary to minimize the risk of ignition.

For repair of the refrigerating system, the following precautions should be complied with prior to conducting work on the system.

Work should be undertaken under a controlled procedure so as to minimize the risk of a flammable gas or vapor being present while the work is being performed.

All maintenance staff and others working in the local area should be instructed on the nature of work being carried out. Work in confined spaces should be avoided. The area around the workspace should be sectioned off. Ensure that the area is safe through control of flammable materials.

The area should be checked with an appropriate refrigerant detector prior to and during work, to ensure the technician is aware of potentially flammable atmospheres.

Ensure that the leak detection equipment being used is suitable for use with flammable refrigerants, i.e., the equipment should be non-sparking, adequately sealed or intrinsically safe. If any hot work is to be conducted on the refrigeration equipment or any associated parts, appropriate fire extinguishing equipment should be available to hand. Have a dry powder or CO₂ fire extinguisher adjacent to the charging area.

No person carrying out work in relation to a refrigeration system which may expose any pipe that contains or has contained flammable refrigerant should use any sources of ignition in such a manner that it may lead to the risk of fires or explosions.

All possible ignition sources, including lighted cigarettes, should be kept sufficiently far away from the site of installation, repair, removal and disposal, during which flammable refrigerant can possibly be released into the surrounding space.

Prior to work, the area around the equipment should be checked to make sure that there are no flammable hazards or ignition risks. "No Smoking" signs should be displayed.

Ensure that the area is in the open or adequately ventilated before breaking into the system or conducting any hot work. A degree of ventilation should continue during the work. The ventilation should safely disperse any released refrigerant and preferably expel it externally into the atmosphere.

For any change of the electrical components, they should be fit for the intended purpose and comply with the correct specifications.

Always follow the manufacturer's maintenance and service guidelines. In case of any doubt, consult the manufacturer's technical department for assistance.

The following checks should be applied to installations using flammable refrigerants:

- The charge size should depend on the size of the room within which refrigerant containing components are installed;
- The ventilation machinery and outlets should operate adequately and not be obstructed;
- If an indirect refrigerating circuit is used, the secondary circuit should be checked for any refrigerant;
- Marking to the equipment should remain visible and legible. Illegible markings and signs should be corrected;
- Refrigeration pipes or components should be installed in positions where they are unlikely to be exposed to any substance which may corrode refrigerant containing components, unless the components are constructed of materials that are inherently resistant to corrosion or are suitably protected against corrosion.

Repair and maintenance of electrical components should include initial safety checks and component inspection procedures.

In the event of a fault that could compromise safety, no power supply should be connected to the circuit until it is satisfactorily dealt with. If the fault cannot be corrected immediately but it is necessary to continue operation, an adequate temporary solution should be used. This should be reported to the owner of the equipment to give advises to all parties involved.

Initial safety checks should include the following:

- Capacitors should be discharged in a safe manner to avoid possibility of sparking;
- No live electrical components and wiring should be exposed while charging, recovering or purging the system;
- The earth bonding should be continuous.

During repairs of sealed components, all power supplies should be disconnected from the equipment where work is in progress prior to any removal of sealed covers or other components. If it is absolutely necessary to keep a power supply connected with the equipment during servicing, a permanent leak detection should be performed at the most critical point to avoid a potential hazard.

Particular attention should be paid to the following to ensure that the casing is not altered in such a way that the level of protection is affected by working on electrical components. This includes damage to cables, an excessive number of connections, terminals not compliance with original specifications, damage to seals, and incorrect fitting of glands.

Ensure that seals or sealing materials have not degraded in such a manner that they no longer serve for the purpose of preventing the ingress of flammable atmospheres. Parts for replacement should be in accordance with the manufacturer's specifications.

Do not apply any permanent inductive or capacitance loads that exceed the permissible voltage or current of the equipment in use to the circuit.

Intrinsically safe components are the only types that can be worked on while live in the presence of a flammable atmosphere. The test apparatus should be provided with the correct rating.

Replace components only with parts specified by the manufacturer. Other parts may result in the ignition of refrigerant in the atmosphere due to a leak.

Check and ensure that cabling is free from wear, corrosion, excessive pressure, vibration, sharp edges or any other adverse environmental effects. The check should also take into account the effects of ageing or continual vibration from sources such as compressors or fans.

When breaking into the refrigerant circuit for repair – or for any other purpose – follow the conventional procedures. However, it is important to follow the best practice.

Since flammability is a consideration, the following procedure should be adhered to:

- Remove the refrigerant;
- Purge the circuit with inert gas;
- Evacuate;
- Purge the circuit again with inert gas;
- Open the circuit by cutting or brazing.

The refrigerant should be recovered into correct recovery cylinders. The system should be “flushed” with OFN to guarantee the unit safety. This process may need to be repeated several times. Compressed air or oxygen should not be used for this task.

Flushing should be achieved by breaking the vacuum in the system with OFN and continuing to fill until the working pressure is achieved before venting to the atmosphere and pulling down to a vacuum. This process should be repeated until no refrigerant exists in the system. When the final OFN charge is used, the system should be vented down to the atmospheric pressure so that the work can start.

This operation is absolutely vital if brazing operations on the pipe-work are to take place.

Ensure that the outlet for the vacuum pump is not close to any ignition sources and adequate ventilation is available.

Ensure that contamination of different refrigerants does not occur when using charging equipment. Hoses or lines should be as short as possible to minimize the amount of refrigerant contained in them. Prior to recharging the system, it should be pressure tested with OFN.

DD.12 Decommissioning:

Before this procedure starts, it is necessary for the technician to be completely familiar with the equipment and all its details. It is recommended that all refrigerants be recovered safely. Prior to the task, an oil and refrigerant sample should be taken in case analysis is required prior to re-use of reclaimed refrigerant. It is essential that electrical power is available before the task is commenced.

- a) Be familiar with the equipment and its operation.
- b) Isolate the system electrically.
- c) Before attempting the procedure, ensure that:
 - Mechanical handling equipment is available, if required, for handling refrigerant cylinders;
 - All personal protective equipment is available and being used correctly;
 - The recovery process is supervised at all times by a competent person;
 - The recovery equipment and cylinders should conform to the appropriate standards.
- d) Pump down refrigerant system, if possible.
- e) If a vacuum is not possible, make a manifold so that refrigerant can be removed from various parts of the system.
- f) Make sure that the cylinders are situated on the scales before recovery.
- g) Start the recovery machine and operate it in accordance with manufacturer's instructions.
- h) Do not overfill the cylinders. (No more than 80 % of volume for liquid charge).

i) Do not exceed the maximum working pressure of the cylinders, even temporarily.

j) When the cylinders have been filled correctly, make sure that the cylinders and the equipment are removed from the site promptly and all isolation valves on the equipment are closed off.

k) Recovered refrigerant should not be charged into another refrigeration system unless it has been cleaned and checked.

Equipment should be labeled stating that it has been de-commissioned and emptied of refrigerant. The label should be dated and signed. Ensure that the equipment is provided with a label stating the existence of flammable refrigerant in the equipment.

When removing refrigerant from a system, either for servicing or decommissioning, it is recommended that all refrigerants be removed safely.

Always transfer refrigerant into appropriate cylinders. Ensure that a correct number of cylinders are available for supporting the total system charge. All cylinders to be used should be designated for the recovered refrigerant and labeled for that refrigerant (i.e. special cylinders for the recovery of refrigerant). The cylinders should be complete with pressure relief valves and associated shut-off valves in good working conditions. Empty recovery cylinders should be evacuated and, if possible, cooled down before recovery occurs.

The recovery equipment should be in good working conditions with a set of instructions concerning the equipment that is at hand and should be suitable for the recovery of flammable refrigerants. In addition, a set of calibrated weighing scales should be available and work properly. Hoses should be complete with leak-free disconnect couplings and work properly. Before using the recovery machine, check and ensure that it is in satisfactory working conditions and has been properly maintained, and that all associated electrical components are sealed to prevent ignition in the event of a refrigerant leak. Consult the manufacturer if in case of any doubt.

The recovered refrigerant should be returned to the refrigerant supplier in correct recovery cylinders, with the relevant Waste Transfer Note arranged. Do not mix refrigerants in recovery units and especially not in cylinders. If any compressor or compressor oils is to be removed, ensure that it has been evacuated to an acceptable level to ensure that flammable refrigerant does not remain within the lubricant. The evacuation process should be carried out prior to returning the compressor to the supplier. To accelerate this process, you can only heat the compressor body with an electric heater. Draining oil from the system should ensure the safety.

Warning: Disconnect the appliance from its power source during servicing and parts replacement.

These units are partial unit air conditioners, complying with partial unit requirements of this International Standard, and must only be connected to other units that have been confirmed as complying to corresponding partial unit requirements of this International Standard.

Leak detection

The following leak detection methods are deemed acceptable for systems containing flammable refrigerants. Electronic leak detectors should be used to detect flammable refrigerants, but the sensitivity may not be adequate, or may need re-calibration. (Detection equipment should be calibrated in a refrigerant-free area.) Ensure that the detector is not a potential source of ignition and is suitable for the refrigerant.

Leak detection equipment should be set at a percentage of the LFL of the refrigerant and should be calibrated to be suitable for the refrigerant employed, with the appropriate percentage of gas (25% maximum) confirmed. Leak detection fluids should be suitable for most refrigerants but the use of detergents containing chlorine should be avoided as the chlorine may react with the refrigerant and corrode the copper pipes. If a leak is suspected, all naked flames should be removed or extinguished. If a leakage of refrigerant is found and brazing is required, all of the refrigerant should be recovered from the system, or isolated (by means of shut off valves) in a part of the system that is far from the leak. The system should be purged with oxygen free nitrogen (OFN) both before and during the brazing process.

Disposal

This equipment uses flammable refrigerants. The disposal of the equipment must comply with national regulations. Do not dispose this product as unsorted municipal waste. Collection of such waste separately for special treatment is necessary.

- Do not dispose of electrical appliances as unsorted municipal waste, and use separate collection facilities.
- Contact your local government for information regarding the collection systems available.

If electrical appliances are disposed of in landfills or dumps, hazardous substances can leak into the groundwater and get into the food chain, damaging your health and well-being.



Caution: Risk of fire

2 GENERAL INTRODUCTION

2.1 Documentation

- Always observe all the operating and installation instructions included with the system components.
- Hand these instructions and all other applicable documents to the end user.

This document is part of a documentation set. The complete set consists of:

Document	Content	Format
Installation Manual (this manual)	Brief installation instructions	Paper (in the box next to the outdoor unit)
Installation, Operation and Maintenance Manual	Preparation for the installation, good practices... (more information contained, for installers and advanced users only)	Digital files..
Operation Manual (wired controller)	Quick guide for basic usage	Paper (in the box next to the outdoor unit)
Technical Data Manual	Performance data and ERP information	Paper (in the box next to the outdoor unit)

Online Tools (APP and websites)

Refer to the OPERATION MANUAL for more information

For the terms and abbreviation, see Annex 3.

2.2 Validity of the Instructions

These instructions apply only to:

Unit	3-phase		
	26	30	35
Net weight (kg)	260		
Wiring specification (mm ²) - main power supply	6-10	6-10	6-10
Minimum flow rate required (m ³ /h)	1.2	1.2	1.2

2.3 Unpacking

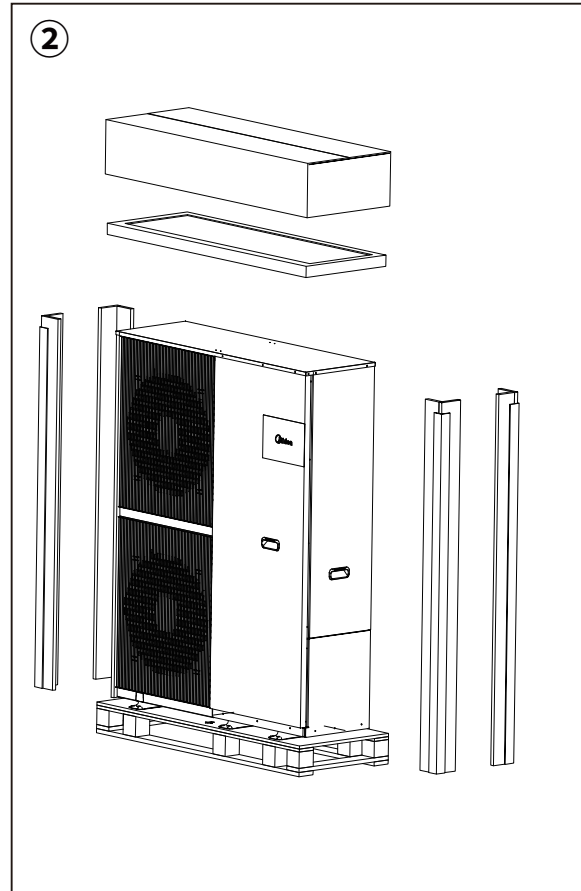
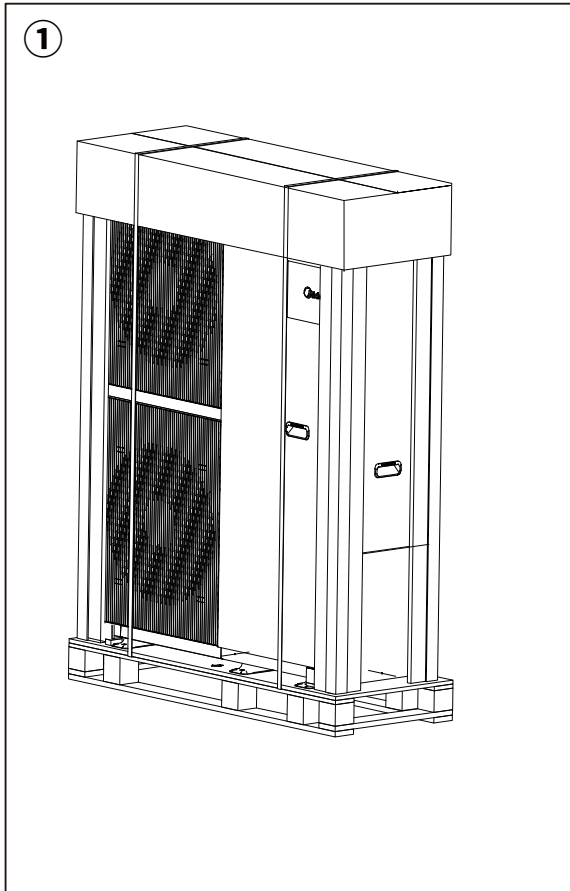

For the accessories box, see 2.4.1 Accessories supplied with the unit for more details.

2.4 Accessories of the Unit

Accessories of the unit			
Name	Illustration	Quantity	Specification
Installation Manual		1	-
Technical Data Manual		1	-
Operation Manual		1	-
Y-shape strainer		1	G1 1/4"
Wired controller box		1	-

Thermistor (T5, Tw2, Tbt)		1	10m
Drain joint		2	φ32
Energy label		1	-
Tie wrap		13	-
Paper edge protector		2	-
Network matching line		1	-
Extension wire for T5, Tw2, Tbt		1	-
Harness buckle		4	-
Wrench		1	-

2.5 Transportation

2.5.1 Dimensions and barycenter

The illustrations below are for 26&30&35 kW units. A, B, and C indicate the locations of barycenter.

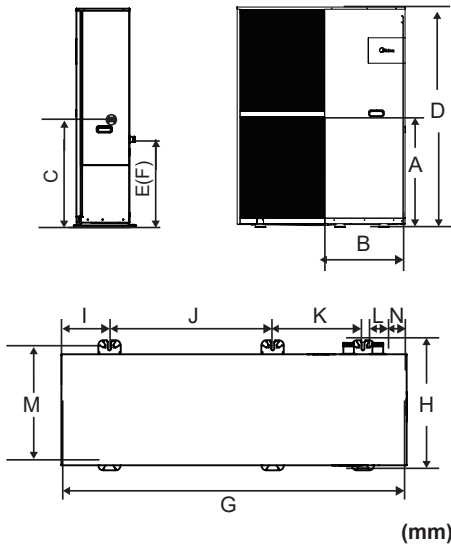

(mm)

Model	A	B	C	D	E
26 & 30 & 35 kW	937	646	985	1816	723

F	G	H	I	J	K	L	M	N
723	1384	523	193	656	363	117	453	116

2.5.2 Manual transportation

⚠ WARNING

Risk of injury from lifting a heavy weight. Lifting weights that are too heavy may cause injury to the spine, for example.

- Note the weight of the product.
- Have four people lift the product.

1. Take into consideration the weight distribution during transportation. The product is significantly heavier on the compressor side than on the fan motor side. (see content above for the barycenter)
2. Protect the casing sections from damage. Using corner protectors under the unit when lift the unit.
3. After transportation, remove the transport straps.
4. During transportation, do not tilt the product to an angle larger than 45°.

2.5.3 Lifting

Use lifting tools with transport straps or a suitable hand truck.

Unit on the pallet:

Pass the transport straps through the holes on the left and right sides of the pallet properly.

No pallet under the unit:

The transport straps can be fitted into foreseen sleeves at the base frame that are made specifically for this purpose. Using corner protectors under the unit when lifting the unit.

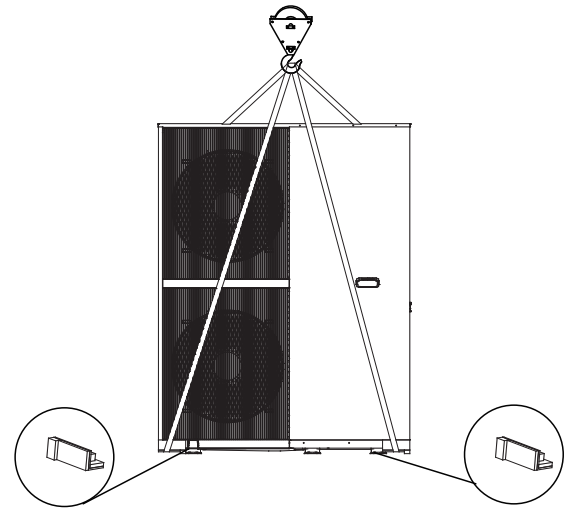

⚠ CAUTION

The barycenter of the product and the hook should be kept in a straight line in the vertical direction to prevent excessive tilting.

2.6 About the Unit

2.6.1 Overview

The unit applies to heating, cooling, and DHW scenarios. It can be used together with fancoil units, floor heating devices, low-temperature high-efficiency radiators, domestic hot water tanks, and solar kits.

The backup heater can increase the heating capacity at extremely low ambient temperatures. It serves as a backup heating source in case of heat pump failure or freeze protection of the water piping outside in winter.

2.6.2 Layout

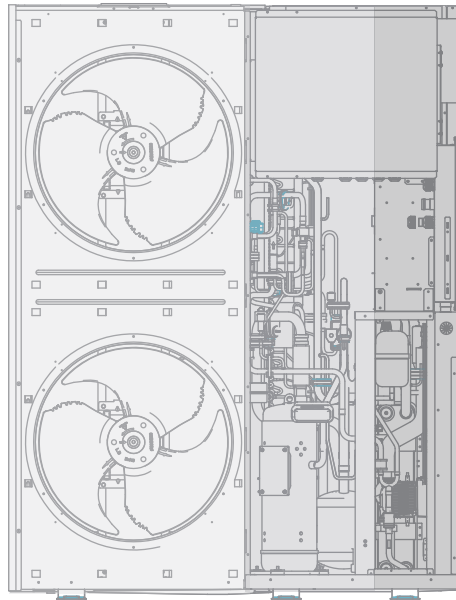

- A – Fan chamber
- B – Mechanical chamber
- C – Hydraulic module

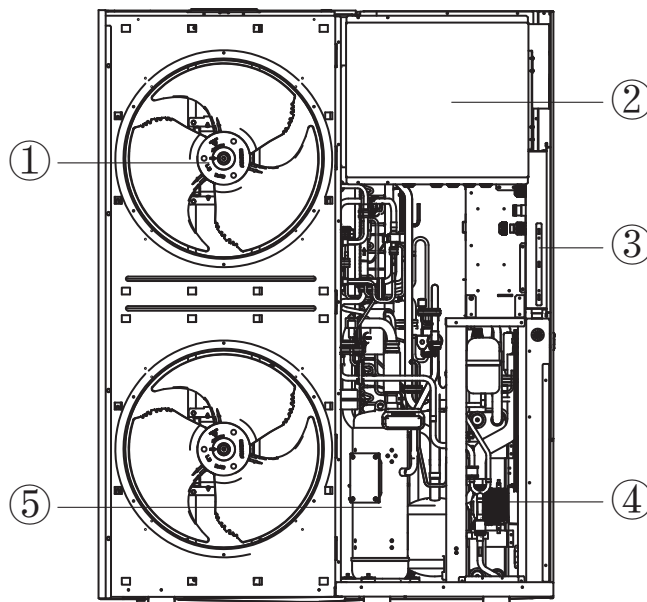

- ① Fan
- ② Inverter control box
- ③ Main control box
- ④ Hydraulic module
- ⑤ Compressor

2.6.3 Hydraulic module

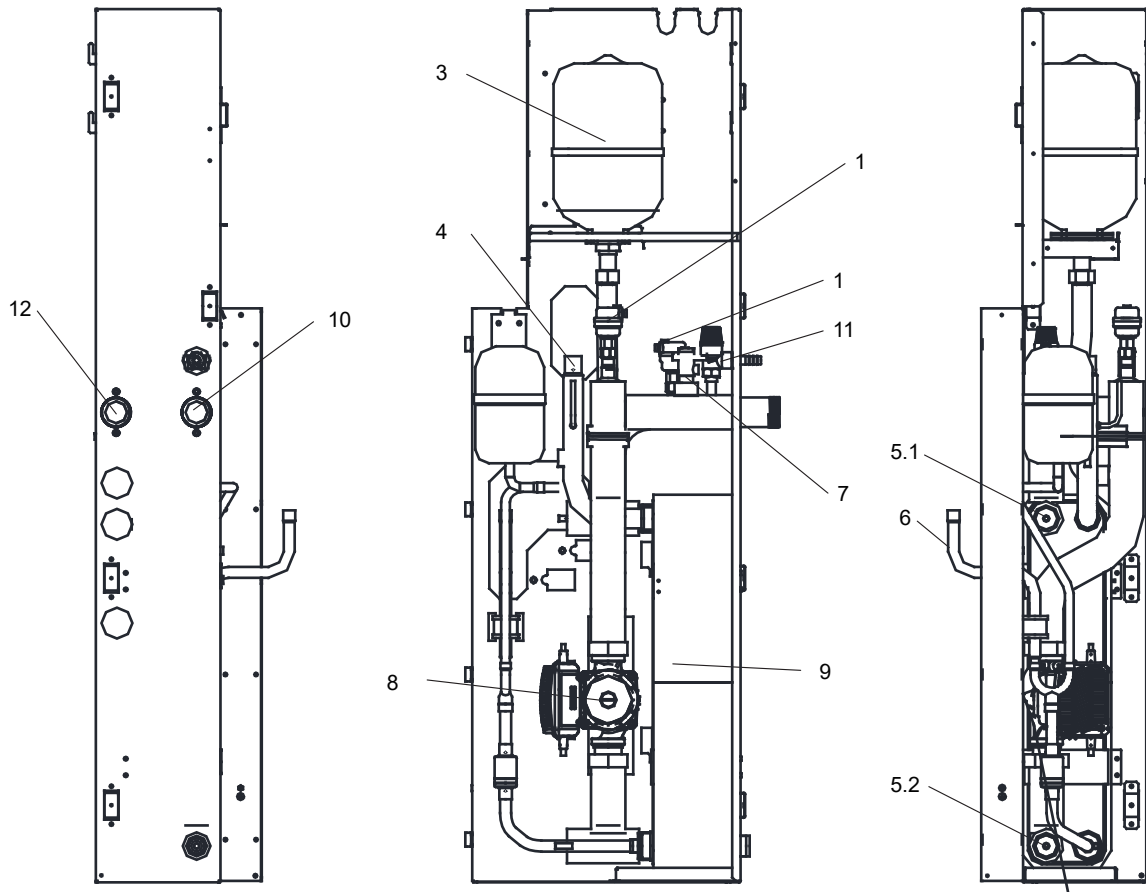

Code	Assembly Unit	Explanation
1	Automatic air purge valve	Automatically removes the remaining air from the water loop.
2	Backup heater (optional)	Provides additional heating capacities when the heating capacity of the heat pump is insufficient due to low outdoor temperature, and protects the external water pipes from freezing.
3	Expansion vessel	Balances the water system's pressure.
4	Refrigerant gas pipe	/
5	Temperature sensor	Four temperature sensors determine the water and refrigerant temperature at various points in the water loop: 5.1-TW_out, and 5.2-TW_in
6	Refrigerant liquid pipe	/
7	Flow switch	Detects the water flow rate to protect the compressor and water pump in the event of insufficient water flow.
8	Pump	Circulates water in the water loop.
9	Plate heat exchanger	Transfers heat from the refrigerant to the water.
10	Water outlet pipe	/
11	Pressure relief valve	Prevents excessive water pressure by opening when the pressure reaches 3 bar and discharging water from the water loop.
12	Water inlet pipe	/

2.6.4 Operating range

In cooling mode, the product works at an outdoor temperature of -15 to 48°C.

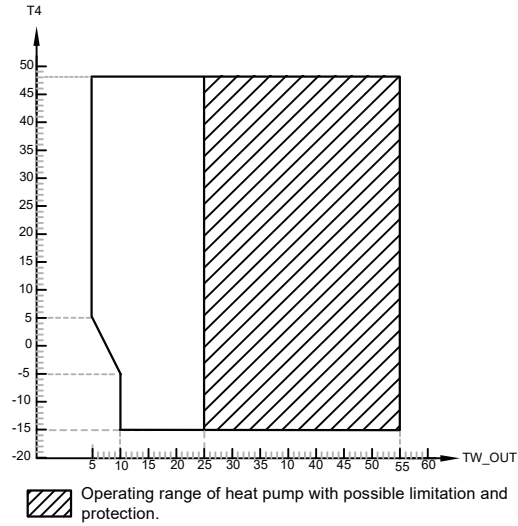

TW_OUT leaving water temperature

T4 outdoor ambient temperature

In heating mode, the product works at an outdoor temperature of -25 to 43°C

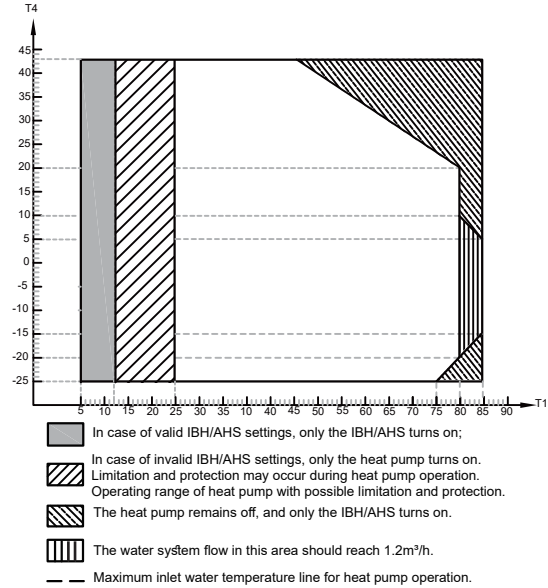

T1 leaving water temperature

T4 outdoor ambient temperature

In DHW mode, the product works at an outdoor temperature of -25 to 43°C

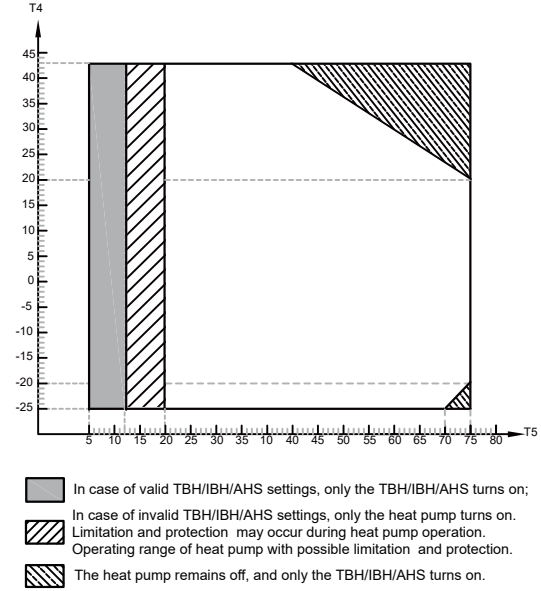

T5 DHW tank temperature

T4 outdoor ambient temperature

3 SAFETY ZONE

The refrigerant circuit in the outdoor unit contains easily flammable refrigerant in safety group A3 as described in ISO 817 and ANSI/ASHRAE Standard 34. Therefore, a safety zone is defined in the immediate vicinity of the outdoor unit, in which special requirements apply. Note that this refrigerant has a higher density than air. In the event of a leak, escaping refrigerant may be collected near the earth. The following conditions must be avoided within the safety zone:

- Building openings such as windows, doors, light wells, and flat roof windows;
- Outdoor air and exhaust air apertures of ventilation and air conditioning systems;
- Property boundaries, neighboring properties, footpaths, and driveways;
- Pump shafts, inlets to waste water systems, downpipes, and waste water shafts, etc.;
- Other slopes, troughs, depressions, and shafts;
- Electrical house supply connections;
- Electrical systems, sockets, lamps, and light switches; Snowfall from roofs.

Do not introduce ignition sources into the safety zone:

- Naked flames or burner gauze assemblies.
- Grills.
- Tools that generate sparks.
- Electrical devices not free of ignition sources, mobile devices with integrated batteries (such as mobile phones and fitness watches).
- Objects with a temperature of above 360°C.

NOTE

The particular safety zone is dependent on the surroundings of the outdoor unit.

- The safety zones below are shown with floor standing installation. These safety zones also apply to other types of installation.

Freestanding positioning of the outdoor unit

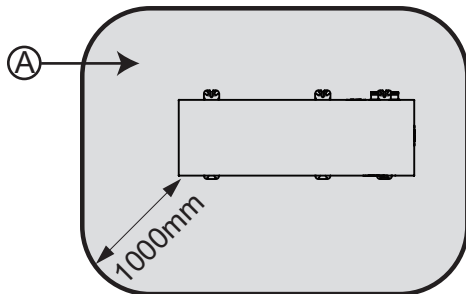

Ⓐ Safety zone

Siting the outdoor unit in front of an external wall

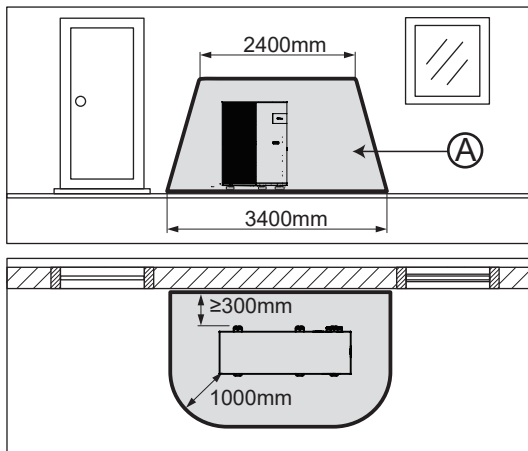

Ⓐ Safety zone

Corner positioning of the outdoor unit, left

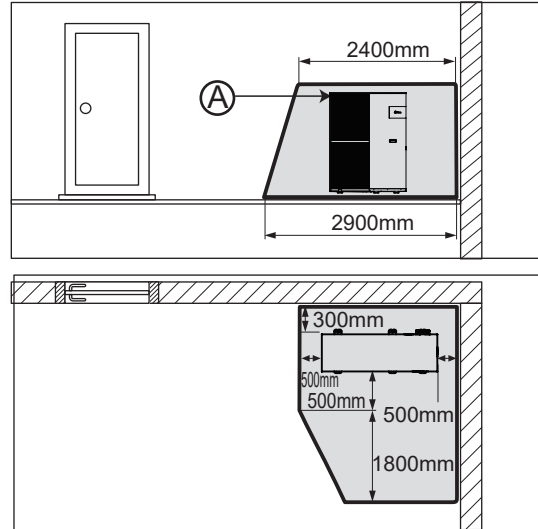

4 UNIT INSTALLATION

For ground installation and flat roof clearance – single unit

General

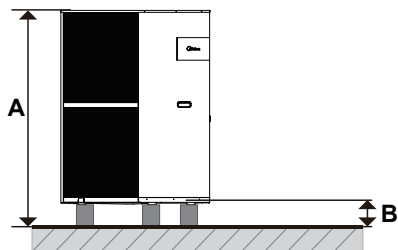

Obstacle over the top

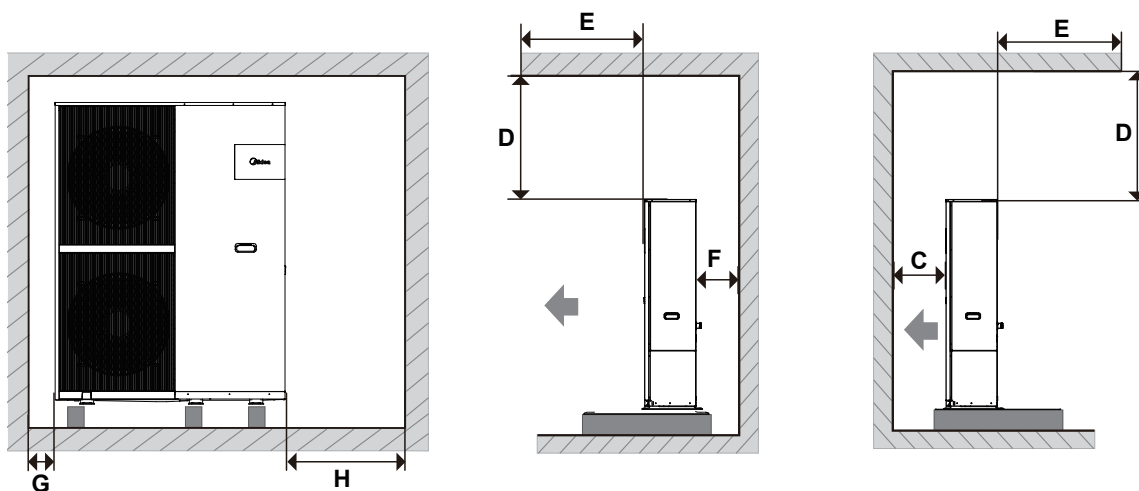

No obstacle over the top

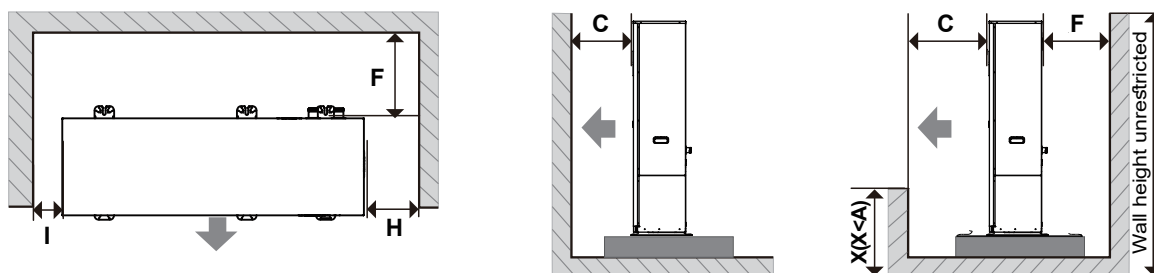

26-35 kW

(mm)

A	Unit height + B	D	≥500	G	≥500
B	≥100*	E	≥500	H	≥500
C	≥1000	F	≥300	I	≥500

* In case of cold weather, take into account of snow on the ground. For more information, refer to 5.5 In Cold Climates.

For cascade application installation clearance, refer to the INSTALLATION, OPERATION AND MAINTENANCE MANUAL.

5 UNIT INSTALLATION

5.1 General Rules

In addition to "Safety zone", the following conditions should be observed.

Environment

- For the sake of safety and unit performance, the installation site must be with sufficient air flow.
- For maintenance and service purposes, the installation site should be highly accessible.
- Impact protection measures should be taken, if the installation site has high impact risks, such as a vehicle shunting area.
- Keep the unit away from flammable substances or flammable gases.
- Keep the unit away from heat sources.
- Keep the unit as far away from raindrops as possible.
- Do not expose the outdoor unit to any dirty, dusty or corrosive atmosphere.
- Keep the unit away from ventilation openings or ventilation ducts.

Nature

Be ware of the impact from the nature:

- Plants with vines could block the air inlet and outlet of the unit as they grow.
- Fallen leaves could block the unit air inlet or stuck the air channel.
- Insects, snakes or some small animals might enter the unit. Wild animals might bite or damage the piping and wiring of the unit.

NOTE

In case of any evidence of animal effects, ask professionals for inspection and maintenance.

Strong wind

- When installing the unit in a place exposed to strong wind, pay special attention to the following: A wind speed of 5 m/s or higher against the unit's air outlet could cause a short circuit (suction of discharge air), which may have the following consequences:
 - Deterioration of the operational capacity.
 - Frequent frosting in heating operation.
 - Disruption of operation due to pressure rise.
- When strong wind blows continuously on the front of the unit, the propeller could start rotating very fast until it breaks.

Noise impact

- Select an installation site that is as far away from living rooms and bedrooms as possible.
- Please note the noise emissions. Select an installation site that is as far away from the windows of adjacent buildings as possible.

Installation by the sea

- If the installation site is in the immediate vicinity of a coastline, ensure that the product is protected against spraying water by an additional protection device.
- Wind from the sea brings saline substances to the land. This could have negative impacts on the unit due to long-time exposure to the saline substances. To prolong the lifetime of the unit, ask professionals for a customized maintenance proposal, and follow the proposal.

Altitude

- The unit is designed to be used below 2000 m of altitude. If it is installed above this level, its performance and reliability cannot be guaranteed.

5.2 Installation Site

The product is suitable for installation on a ground, wall or flat roof.

NOTE

Installation on a pitched roof (inclined place) is not permitted.

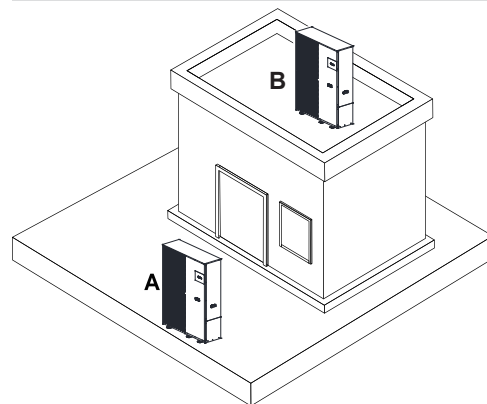

(A) Installation on a ground
(B) Installation on a flat roof

5.2.1 Precautions for installation on a ground

- Avoid any installation site that is in the corner of a room, between walls or between fences.
- Prevent the return intake of air from the air outlet.
- Ensure that water cannot accumulate on the subsoil.
- Ensure that the subsoil can absorb water well.
- Plan a bed of gravel and rubble for the condensate discharge.
- Select an installation site that is free from significant accumulations of snow in winter.
- Select an installation site at which the air inlet is not affected by strong wind. Position the unit crosswise to the wind direction whenever it is possible.
- If the installation site is not protected against wind, a protective wall is required.
- Please note the noise emissions. Avoid corners of rooms, recesses or sites between walls.
- Select an installation site with excellent sound absorption performance such as those with grass, hedges or fencing.
- Route the hydraulic lines and electrical wires underground.
- Provide a safety pipe that leads from the outdoor unit through the wall of the building.

5.2.2 Precautions for installation on a flat roof

- Only install the product in a building with a solid construction structure and that has cast concrete ceilings throughout.
- Do not install the product in any building with a wooden structure or with a lightweight roof.
- Select an installation site that is easily accessible so that foliage or snow can be regularly removed from the product.
- Select an installation site at which the air inlet is not affected by strong wind. Position the unit crosswise to the wind direction whenever it is possible.
- If the installation site is not protected against wind, a protective wall is required.
- Please note the noise emissions. Maintain a sufficient clearance from adjacent buildings.
- Route the hydraulic lines and electrical wires.
- Provide a wall duct.

5.2.3 Occupational safety

Installation on a flat roof

- Ensure that the flat roof can be safely accessed.
- Maintain a safety area that is 2 m from falling edges, and a clearance that is required for working on the product. The safety area must be inaccessible.
- If this is not possible, install technical falling protections at the falling edges such as reliable railings. Alternatively, set up technical safety equipment such as scaffolding or safety nets.
- Maintain a sufficient clearance from any roof escape hatches and flat-roof windows. Use suitable protective equipment (e.g. barriers) to prevent people from stepping on or falling through any escape hatches and flat-roof windows.

5.3 Foundation and Unit Installation

5.3.1 Installation on a ground

Installation on a soft ground

In case of installation on a soft ground such as lawn and soil, create a foundation as shown in the figure below.

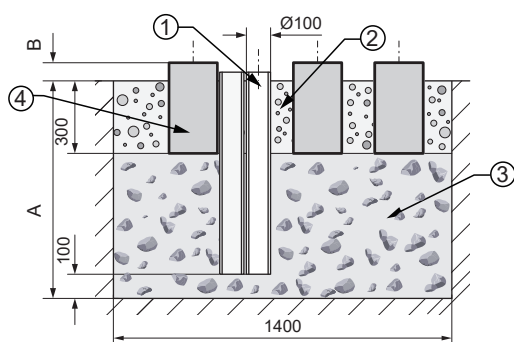

- 1) Downpipe for drainage
 - 2) Strip foundations
 - 3) Water-permeable coarse rubble
 - 4) Concrete strip foundations
- Dig a hole in the ground. For the location of the downpipe, refer to 5.4.1 Drain hole position.
 - Insert a downpipe (1) to divert the condensate.
 - Add a layer of water-permeable coarse rubble (3).
 - Calculate the depth (A) in accordance with local conditions.
 - Region with ground frost: minimum depth: 900 mm
 - Region without ground frost: minimum depth: 600 mm

- Calculate the height (B) in accordance with local conditions. Such height should not be smaller than 100 mm.
- Create three concrete strip foundations (4). The recommended dimensions can be found in the figure.
- Make sure the three foundations are level.
- There are no restrictions on the width or length of the foundations, provided that the unit can be mounted on the foundation properly and the downpipe for drainage is not blocked.
- Add a gravel bed between and beside the strip foundations (2) to divert the condensate.

Installation on a solid ground

In case of installation on a solid ground such as concrete, create a concrete strip foundation comparable to what is described in the section above. The height of the strip foundation should not be smaller than 100 mm.

Unit mounting

Installation with foundation: Fix the unit with foundation bolts. (Six sets of $\Phi 10$ expansion bolts, nuts and washers are needed, which are provided by the user). Screw the foundation bolts to a depth of 20 mm into the foundation. Installation without foundation: Install proper anti-vibration pads and level the unit.

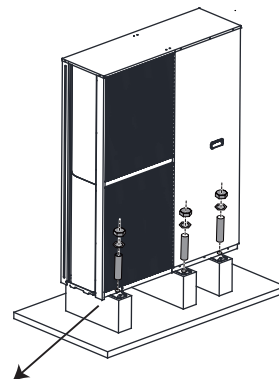

Anti-vibration pad

5.3.2 Installation on a flat roof

In case of installation on a flat roof, create a concrete strip foundation comparable to what is described in 5.3.1 Installation on a ground. The height of the strip foundation should not be smaller than 100 mm.

- Take drainage layout into consideration, and install the unit close to the drainage.

Unit mounting

Same as 5.3.1 Installation on a ground.

5.4 Drainage

5.4.1 Drain hole position

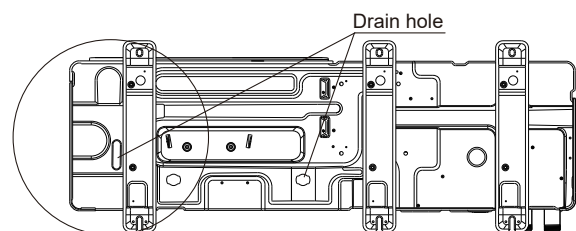

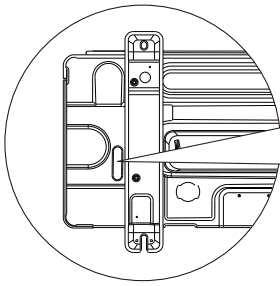

This drain hole is covered by a rubber plug. If the small drain hole cannot meet the drainage requirements, the big drain hole can be used instead.

⚠ CAUTION

- Watch the condensate when removing the rubber plug of the additional drain hole.
- Make sure the condensate is drained properly. Collect and direct the drip from the base of the unit to a drain tray. Prevent water dripping onto the floor that may generate a slip hazard, especially in winter.
- For cold climate with high humidity, it is highly recommended that a bottom plate heater be installed to avoid damage to the unit due to the drain water freezing in case of a low drainage rate.
- Collect and direct the condensate that can drip from the base of the unit to a drain tray.
- Prevent water dripping onto the floor that may generate a slip hazard, especially in winter.

5.4.2 Drainage layout (installation on a ground)

Drain joint

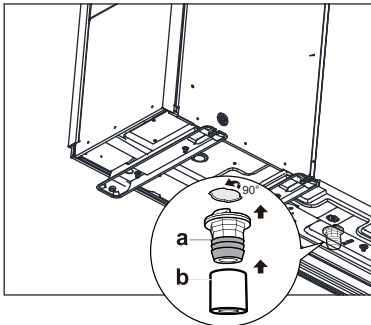

- a – Drain joint (plastic, Pagoda connection, 1")
- b – Drain hose (field supply)

Installation on a soft ground

Draining condensate into a gravel bed

For installation on a ground, the condensate must be discharged through a downpipe into a gravel bed that is located in a frost-free area.

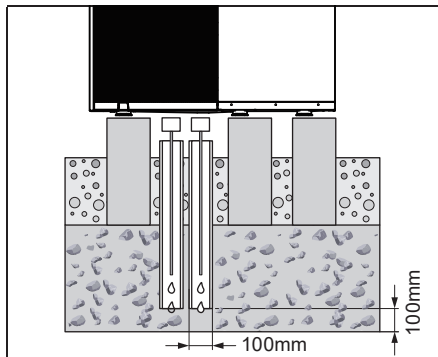

The downpipe must flow into a sufficiently large gravel bed so that the condensate can trickle away freely.

💡 NOTE

To prevent the condensate from freezing, the heating wire must be threaded into the downpipe through the condensate discharge.

Draining condensate through a pump sump/soakaway

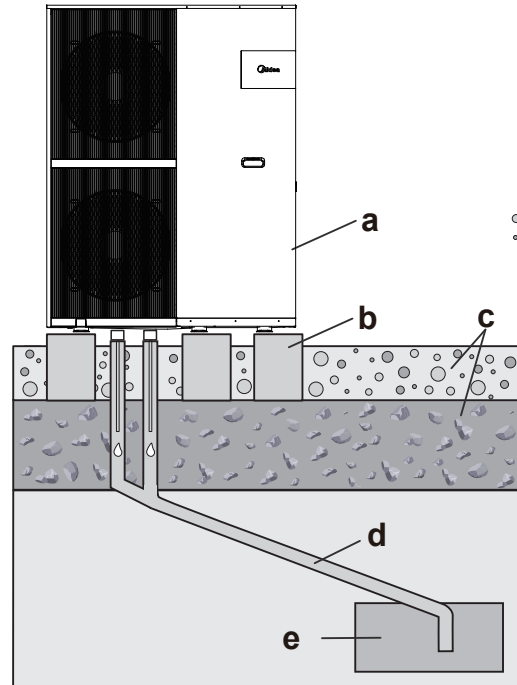

- a – Outdoor unit
- b – Concrete strip foundations
- c – Foundation (See 5.3.1 Installation on a ground)
- d – Drain pipe (at least DN 40)
- e – Pump sump/soakaway

Sewer

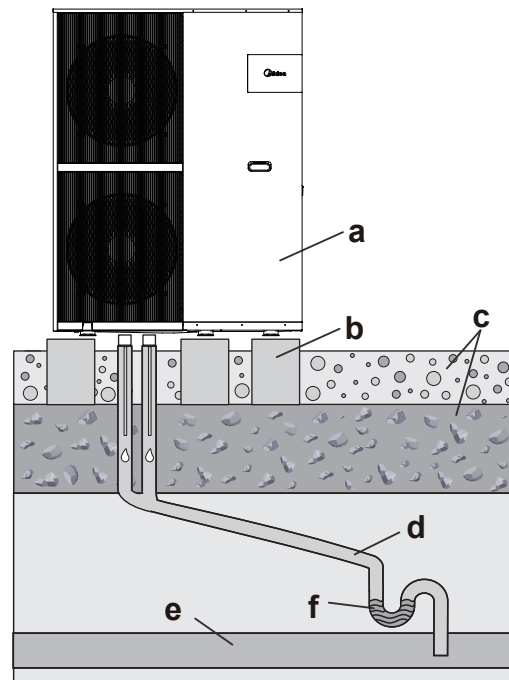

- a – Outdoor unit
- b – Concrete strip foundations
- c – Foundation (See 5.3.1 Installation on a ground)
- d – Drain pipe (at least DN 40)
- e – Sewer
- f – Stench trap in an area free from frosting risks

Installation on a solid ground

Guide the condensation pipe to a sewer, pump sump or soakaway.

The drain plug in the accessory pack cannot bend to another direction. For this, use a hose to guide the condensate into a sewer, pump sump or soakaway through a gully, balcony run-off or roof run-off.

Open gullies within the safety zone do not pose any safety risk.

Installation on a flat roof

Refer to Installation on a solid ground.

NOTE

For all installation types, ensure that any accumulated condensate is discharged in a frost-free manner.

To prevent the condensate from freezing, the heating tape can be threaded into the downpipe through the condensate discharge.

5.5 In Cold Climates

It is recommended that the unit be placed with the rear side against the wall.

Install a lateral canopy on top of the unit to prevent lateral snowfall in extreme weather conditions.

Install a high pedestal or wall mount the unit to keep a proper clearance (at least 100 mm) between the unit and snow.

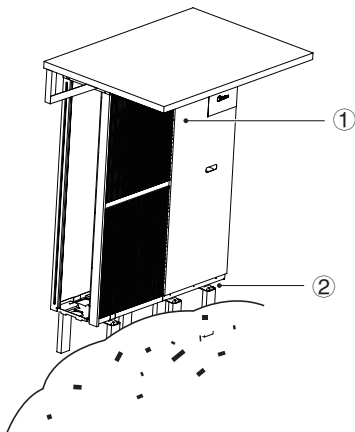

- ① Canopy or alike
- ② Pedestal in case of installation on a ground

5.6 Exposure to Strong Sunlight

Long time of exposure of the ambient temperature sensor of the unit to sunlight might impact the sensor negatively, and cause undesirable impacts on the unit. Shade the unit with a canopy or alike.

6 HYDRAULIC INSTALLATION

6.1 Preparations for Installation

NOTE

- In case of plastic pipes, make sure they are fully oxygen-tight according to DIN 4726.
- The diffusion of oxygen into the piping can lead to excessive corrosion.

System water volume

Check the total water volume in the installation according to the expansion vessel.

For the selection of expansion vessel, refer to INSTALLATION, OPERATION AND MAINTENANCE MANUAL.

Flow rate range

The operation flow rate range of the unit is shown as below. Check and ensure that the flow rate in the installation is guaranteed in all conditions.

Unit	Flow rate range(m ³ /h)
26kW	1.2-5.4
30kW	1.2-6.2
35kW	1.2-7.2

6.2 Water Loop Connection

Typical workflow

Connecting the water loop typically consists of the following steps:

- 1) Connect the water piping to the outdoor unit.
- 2) Connect the drain hose to the drain.
- 3) Fill the water loop.
- 4) Fill the domestic hot water tank (if available).
- 5) Insulate the water piping.

Requirements

NOTE

- The pipe inside must be clean.
- Hold the pipe end downwards when removing burrs.
- Cover the pipe end when inserting the pipe through a wall to prevent dust and dirt from entering the pipe.
- Use proper thread sealant to seal the connections. The sealing must be able to withstand the pressure and temperature of the system.
- When using non-copper metallic piping, be sure to insulate two kinds of materials from each other to prevent galvanic corrosion.
- Copper is soft. Use appropriate tools to avoid damage.
- Zn-coated parts cannot be used.
- Always use materials that do not react with the water used in the system and with the materials used in the unit.
- Ensure that components installed in the field piping can withstand the water pressure and temperature.

⚠ CAUTION

Incorrect orientation of water outlet and inlet could cause unit malfunction.

Do NOT apply excessive force when connecting the field piping and make sure the piping is aligned properly. Water piping deformation could cause unit malfunction.

The unit is only to be used in a closed water system (See 3.9 Typical Applications).

- 1) Connect the Y-shaped strainer to the water inlet of the unit, and seal the connection with thread sealant. (To provide access to the Y-shaped strainer for cleaning, an extension pipe can be connected between the strainer and the water inlet depending on the field conditions)
- 2) Connect the pipe provided on the site to the water outlet of the unit.
- 3) Connect the outlet of the safety valve with a hose with a suitable size and length, and guide the hose to the condensate 5.4.2 Drainage layout.

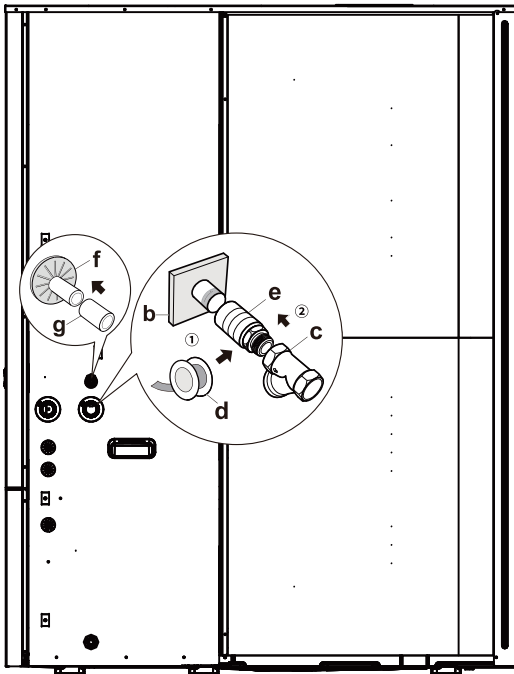

a	Water OUTLET (connection with screws, male)
b	Water INLET (connection with screws, male)
c	Y-shaped strainer (delivered with the unit) (2 screws for connection, female)
d	Thread seal tape
e	Extension pipe (recommended, with the length depending on the field conditions)
f	Safety valve outlet (hose, $\phi 16\text{mm}$)
g	Drain hose (supplied on the site)

Domestic hot water

For the installation of the domestic hot water tank (supplied on the site), refer to the specific manual of the domestic hot water tank.

Others

💡 NOTE

- Air vent valves must be installed at high points of the system.
- Drain taps must be installed at low points of the system.

6.3 Water

Checking and treating the water/filling and supplementing water

- Before filling or topping up the installation, check the quality of the water.

💡 NOTE

- Risk of material damage due to poor-quality water.
- Ensure that the water is of sufficient quality.
- Water quality should be complied with EN 98/83 EC Directives.

Checking the filling and supplementary water

- Before filling the installation, measure the hardness of the filling and supplementary water.

Checking the quality of the water

- 1) Remove a little water from the heating circuit.
- 2) Check the appearance of the water.
 - If it is determined that the water contains sedimentary materials, be sure to desludge the installation.
- 3) Use a magnetic rod to check whether the water contains magnetite (iron oxide).
 - If you ascertain that it contains magnetite, clean the installation and take suitable corrosion-inhibition measures, or install a magnetite separator.
- 4) Check the pH value of the removed water at 25 °C.
 - If the value is below 8.2 or above 10.0, clean the installation and treat the water.

💡 NOTE

Ensure that oxygen cannot get into the water.

Treating the filling and supplementary water

- Observe all applicable national regulations and technical rules when treating the filling and supplementary water.

Provided the national regulations and technical rules do not stipulate more stringent requirements, the following applies:

You must treat the water in the following cases.

- If the entire filling and supplementary water quantity during the service life of the system exceeds three times the nominal value of the water loop, or
- If the guideline values listed in the following table are not met, or
- If the pH value of the water is smaller than 8.2 or larger than 10.0.

Validity: Denmark or Sweden

Total heating output	Water hardness at specific system volume ¹⁾					
	≤20 l/kW		>20 l/kW and ≤50 l/kW		> 50 l/kW	
kW	°dH	mol/m ³	°dH	mol/m ³	°dH	mol/m ³
<50	< 16.8	< 3	11.2	2	0.11	0.02
>50 and ≤200	11.2	2	8.4	1.5	0.11	0.02
>200 and ≤600	8.4	1.5	0.11	0.02	0.11	0.02
>600	0.11	0.02	0.11	0.02	0.11	0.02

1) Nominal capacity in liters/heat output; In the case of multi-boiler systems, the smallest single heat output is to be used.

Validity: Great Britain

Total heating output	Water hardness at specific system volume ¹⁾					
	≤20 l/kW		>20 l/kW and ≤50 l/kW		> 50 l/kW	
kW	ppm CaCO ₃	mol/m ³	ppm CaCO ₃	mol/m ³	ppm CaCO ₃	mol/m ³
<50	< 300	< 3	200	2	2	0.02
>50 and ≤200	200	2	150	1.5	2	0.02
>200 and ≤600	150	1.5	2	0.02	2	0.02
>600	2	0.02	2	0.02	2	0.02

1) Nominal capacity in liters/heating output; In the case of multi-boiler systems, the smallest single heating output is to be used.

Validity: Finland or Norway

Total heating output	Water hardness at specific system volume ¹⁾					
	≤20 l/kW		>20 l/kW and ≤50 l/kW		> 50 l/kW	
kW	mg CaCO ₃ /l	mol/m ³	mg CaCO ₃ /l	mol/m ³	mg CaCO ₃ /l	mol/m ³
<50	< 300	< 3	200	2	2	0.02
>50 and ≤200	200	2	150	1.5	2	0.02
>200 and ≤600	150	1.5	2	0.02	2	0.02
>600	2	0.02	2	0.02	2	0.02

1) Nominal capacity in liters/heating output; In the case of multi-boiler systems, the smallest single heating output is to be used.

6.4 Filling Water Loop with Water

NOTE

Before filling with water, please check 6.3 Water for the water quality requirements. Pumps and valves may become stuck as a result of poor water quality.

- Connect the water supply to the filling valve and open the valve. Follow applicable regulations.
- Make sure the automatic air vent valve is open.
- Ensure a water pressure of approximately 2.0 bar. Remove the air in the loop as much as possible using the air vent valves. Air in the water loop could lead to malfunction of the backup electric heater.

Do not fasten the black plastic cover on the vent valve at the top side of the unit when the system is running. Open the air vent valve, and turn it anticlockwise at least 2 full turns to release air from the system.

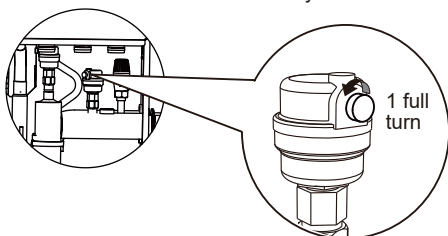

NOTE

During filling, it might not be possible to remove all air from the system. Remaining air will be removed through the automatic air purge valves during the first operation of the system.

Topping up with water afterwards might be required.

- The water pressure will vary with the water temperature (a higher pressure at a higher water temperature). Always keep the water pressure above 0.3 bar to prevent air from entering the loop.
- The unit might drain off too much water through the pressure relief valve.

Maximum water pressure

3 bar

6.5 Filling Domestic Hot Water Tank with Water

See the specific manual of the domestic hot water tank.

6.6 Water Pipe Insulation

The complete water loop including all pipes, must be insulated to prevent condensation during cooling operation, heating and cooling capacity reduction, and freezing of the outside water pipes in winter.

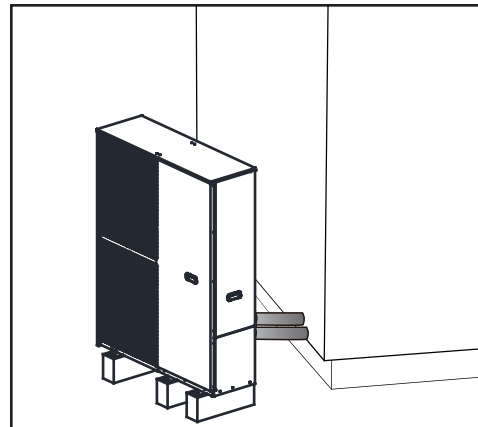

NOTE

- The insulation material should be provided with a fire resistance rating of B1 or above and comply with all applicable regulations.
- The thermal conductivity of the sealing material should be below 0.039 W/mK.

Recommended thickness of the sealing material is shown as below.

Piping length (m) between the unit and the terminal device	Minimum insulation thickness(mm)
< 20	19
20~30	32
30~40	40
40~50	50

If the outdoor ambient temperature is higher than 30°C and the humidity is higher than RH 80%, the thickness of the sealing materials should be at least 20 mm to avoid condensation on the surface of the seal.

6.7 Freeze Protection

6.7.1 Protected by software

The software is equipped with specific functions to protect the entire system from freezing by using the heat pump and the backup heater (if available).

- When the temperature of the water flow in the system drops to a certain value, the unit will heat the water using the heat pump, electric heating tape, or backup heater.
- The anti-freeze function is enabled only when the temperature increases to a certain value.

CAUTION

- In the event of power failure, the above features would fail to protect the unit from freezing. Therefore, always keep the unit powered on.
- If the power supply for the unit is to be switched off for a long time, the water in the system pipe needs to be drained to avoid damage to the unit and pipeline system due to freezing.
- In case of power failure, add glycol to the water. Glycol lowers the freezing point of the water.

6.7.2 Protected by glycol

Glycol lowers the freezing point of water.

CAUTION

Ethylene glycol and propylene glycol are toxic.

CAUTION

Glycol can corrode the system. When uninhibited glycol comes into contact with oxygen, it becomes acidic. This corrosion process is accelerated by copper and high temperature. The acidic uninhibited glycol attacks metal surfaces, forming galvanic corrosion cells that can cause severe damage to the system. Therefore, it is important to follow these steps:

- Let a qualified specialist treat the water correctly;
- Select a glycol with corrosion inhibitors to counteract acids formed by the oxidation of glycols;
- Do not use any automotive glycol because its corrosion inhibitors have a limited lifetime and contain silicates which can contaminate or block the system;
- Do not use galvanized pipes in glycol systems as such pipes may lead to the precipitation of certain components in the glycol's corrosion inhibitor.

NOTE

Glycol absorbs moisture from the environment, so it is important to avoid using glycol exposed to air. If glycol is left uncovered, the water content increases, lowering the glycol concentration and potentially causing hydraulic components to freeze. To prevent this, take precautions and minimize glycol's exposure to air.

Types of glycol

The types of glycol that can be used depend on whether the system contains a domestic hot water tank:

If	Then
The system contains a domestic hot water tank	Only use propylene glycol (a)
The system does NOT contain a domestic hot water tank	Either propylene glycol(a) or ethylene glycol can be used

(a) Propylene glycol, including the necessary inhibitors, falls in Category III according to EN1717.

Required concentration of glycol

The required concentration of glycol depends on the lowest expected outdoor temperature, and on whether you want to protect the system from bursting or from freezing. To prevent the system from freezing, more glycol is required.

Add glycol according to the table below.

Lowest expected outdoor temperature	Prevention from bursting	Prevention from freezing
-5°C	10%	15%
-10°C	15%	25%
-15°C	20%	35%
-20°C	25%	N/A*
-25°C	30%	N/A*
-30°C	35%	N/A*

* Additional action is needed to prevent freezing.

- Protection from bursting: Glycol can prevent the piping from bursting, but cannot prevent the liquid inside the piping from freezing.
- Protection from freezing: Glycol can prevent the liquid inside the piping from freezing.

NOTE

- The required concentration might vary depending on the type of glycol used. ALWAYS compare the requirements from the table above with the specifications provided by the glycol manufacturer. If necessary, meet the requirements set by the glycol manufacturer.
- The added concentration of glycol should NEVER exceed 35%.
- If the liquid in the system is frozen, the pump will NOT be able to start. Please note that solely preventing the system from bursting may not prevent the liquid inside from freezing.
- If water remains stagnant within the system, it is highly likely to freeze and result in system damage.

Glycol and the maximum allowed water volume

Adding glycol to the water loop reduces the maximum allowed water volume of the system. For more information, see 6.1.2 Maximum water volume.

6.7.3 About freeze protection valves (supplied by the user)

NOTE

Do NOT install freeze protection valves, if glycol is added to the water. Otherwise, glycol may leak from the freeze protection valves.

When no glycol is added to the water, you can use freeze protection valves to drain the water from the system before it freezes.

- Install freeze protection valves (supplied by the user) at all lowest points of the field piping.
- Normally closed valves (located indoors near the piping entry/exit) can prevent drainage of water from indoor piping when the freeze protection valves are open.

NOTE

When freeze protection valves are installed, ensure the minimum cooling set point is 7°C (7°C=default). Otherwise, freeze protection valves can open during cooling operation.

6.7.4 Measure without freeze protection

In cold environments, if there is no antifreeze (e.g. glycol) in the system or lasting power failure or pump failure is foreseen, drain the system (as shown in the figure below).

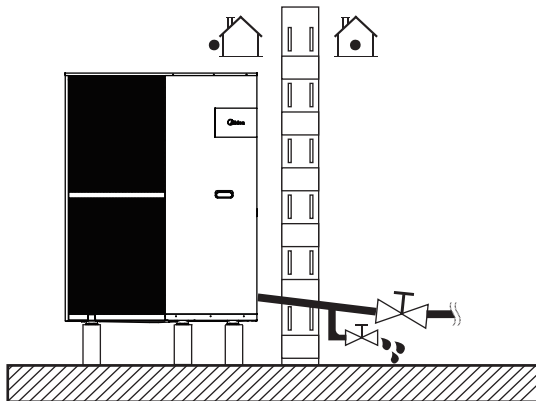

NOTE

If water is not removed from the system in freezing weather when the unit is not in use, the frozen water may damage the water circle parts.

6.7.5 Freeze protection for water loop

All internal hydronic parts are insulated to reduce heat loss. The field piping must also be insulated. In the event of a power failure, the above features would not protect the unit from freezing.

The software contains special functions using the heat pump and backup heater (if optional and available) to protect the entire system from freezing. When the temperature of the water flow in the system drops to a certain value, the unit will heat the water, either using the heat pump, the electric heating tap, or the backup heater. The anti-freeze function will be disabled only when the temperature increases to a certain value.

Water may enter the flow switch and cannot be drained out, and may freeze when the temperature is low enough. The flow switch should be removed and dried before being installed in the unit.

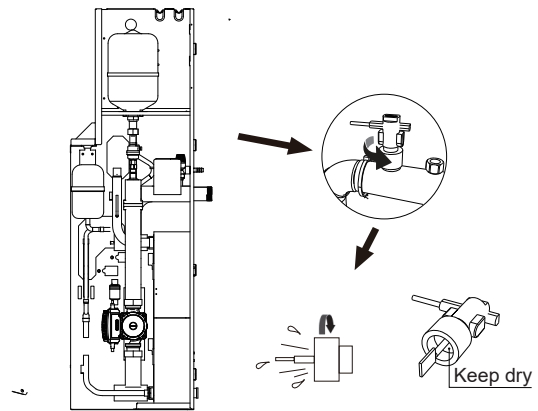

NOTE

- Rotate the flow switch counterclockwise to remove it.
- Dry the flow switch completely.

6.8 Check of Water Loop

The conditions below should be met before installation:

- The maximum water pressure is smaller than or equal to 3 bar.
- The maximum water temperature is smaller than or equal to 85°C according to safety device setting.
- Drain taps must be installed at all low points of the system to ensure complete drainage of the circuit during maintenance.
- Air purge valves must be installed at all high points of the system. The vents should be located at points that are easily accessible for service. An automatic air purge valve is provided inside the unit. Verify that this air purge valve is not tightened so that automatic release of air from the water loop is possible.

7 ELECTRICAL INSTALLATION

⚠ DANGER

Risk of electrocution.

7.1 Opening the Electrical Box Cover

To access the unit for installation and maintenance, follow the instructions below.

⚠ WARNING

Risk of electrocution.
Risk of burning.

💡 NOTE

Keep the screws properly for later use.

Refer to the INSTALLATION, OPERATION AND MAINTENANCE MANUAL for more practical instructions. Refer to the INSTALLATION, OPERATION AND MAINTENANCE MANUAL for more practical instructions.

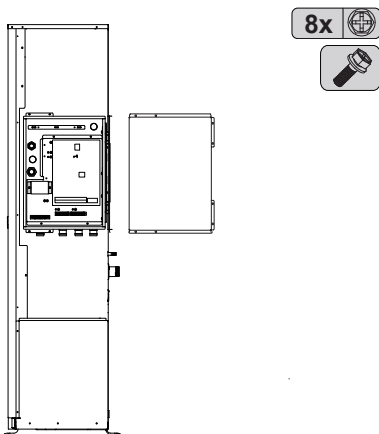
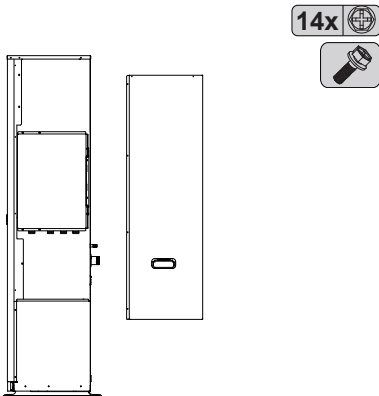

7.2 Back plate layout for wiring

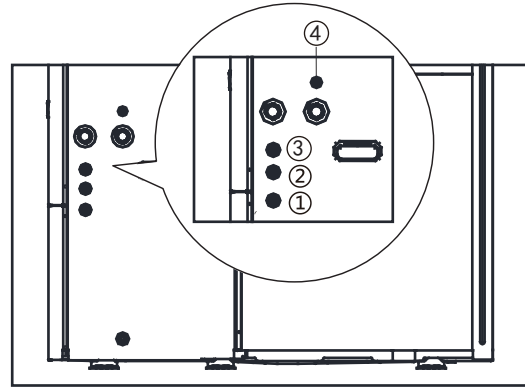

①	For main power wiring.
②	For high voltage wiring.
③	For low voltage wiring.
④	Safety valve drain.

Tightening torques

Item	Tightening torque (N•m)
M6 (power terminal)	2.8-3.0
M6 (earthing)	2.8-3.0
M4 (electric control board terminal)	1.2-1.5

7.3 Electrical Wiring Guidelines

7.3.1 Operating current and wire diameter

1) Select the wire diameter (minimum value) individually for each unit based on Table 7-1 and Table 7-2. The rated current in Table 7-1 means MCA in Table 7-2. In case the MCA exceeds 63 A, the wire diameters should be selected according to the local wiring regulation.

2) The maximum allowable voltage deviation between phases is 2%.

3) Select circuit breakers that have a contact separation of at least 3 mm in all poles for full disconnection. MFA is used to select the current circuit breakers and residual current operation breakers.

4) The drive electronic control box is equipped with an overcurrent protector (fuse). In case any additional overcurrent protector is needed, refer to the TOCA in Table 7-2.

NOTE

- (a) Minimum cable section AWG18 (0.75 mm²).
- (b) The thermistor cable is delivered with the unit.

Table 7-1

Rated current (A)	Nominal cross-sectional area (mm ²)	
	Flexible cord	Cable for fixed wiring
≤ 3	0.5 and 0.75	1 and 2.5
>3 and ≤6	0.75 and 1	1 and 2.5
>6 and ≤10	1 and 1.5	1 and 2.5
>10 and ≤16	1.5 and 2.5	1.5 and 4
>16 and ≤25	2.5 and 4	2.5 and 6
>25 and ≤32	4 and 6	4 and 10
>32 and ≤50	6 and 10	6 and 16
>50 and ≤63	10 and 16	10 and 25

Table 7-2

3-phase 26-35kW

System	Outdoor unit				Power current		
	Voltage (V)	Hz	Min. (V)	Max. (V)	MCA (A)	TOCA (A)	MFA (A)
26kW 3-PH	380-415	50	342	456	28	35	40
30kW 3-PH	380-415	50	342	456	30	35	40
35kW 3-PH	380-415	50	342	456	32	35	40

MCA: max. circuit current. (A)

TOCA: total over current (A)

MFA: max. fuse current (A)

7.4 Connection with Power Supply

7.4.1 Wiring of main power supply

⚠ CAUTION

- Use a round crimp-style terminal for connection to the power supply terminal board.
- The power cord model is H05RN-F or H07RN-F.
- Illustrations below are for 3-phase units.
- Illustrations below are for units with a backup heater.

Refer to the INSTALLATION, OPERATION AND MAINTENANCE MANUAL for more information. Refer to the INSTALLATION, OPERATION AND MAINTENANCE MANUAL for more information.

3 phase without backup heater.

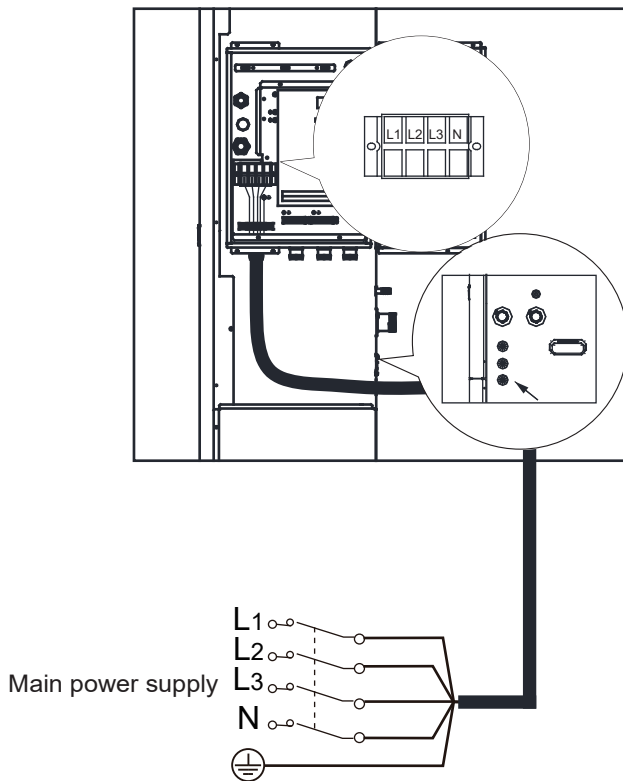

⚠ CAUTION

Leakage protection switch must be installed.

💡 NOTE

- The installation of the Y-shaped strainer at the water inlet is mandatory
- Pay attention to the correct flow direction of the Y-shaped strainer.

7.5 Connection of Other Components

The port provides the control signal to the load. Two kinds of control signal ports:

- Type 1: dry contactor without voltage.
- Type 2: The port provides the signal with 220-240V~50Hz voltage.

💡 NOTE

- If the current of load is smaller than 0.2 A, load can connect to the port directly. If the load current is larger than or equal to 0.2sA, it is necessary to connect the AC contactor to the load.
- Illustrations below are for 3-phase units. The principle is the same for 1 -phase units.
- Illustrations below are based on units with a backup heater.

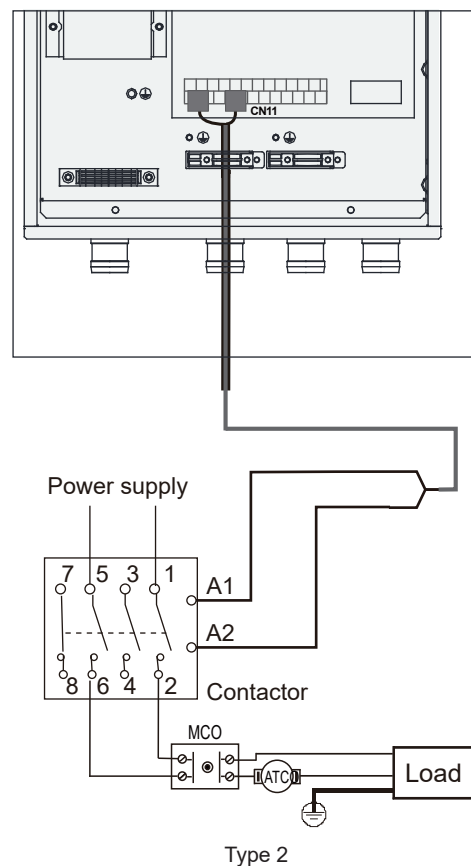
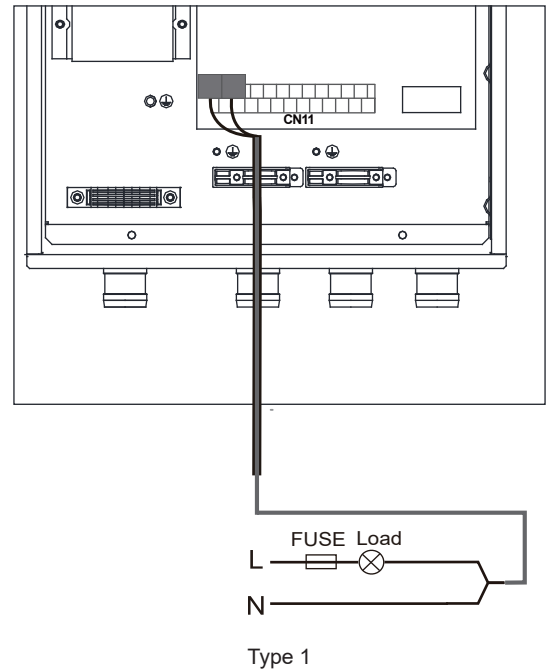

Control signal port of hydraulic module: The CN11 contains terminals for the 3-way valve, pump, booster, and heater, etc.

Connect the cable to an appropriate terminal as shown in the figure and fix the cable reliably.

7.5.1 Wiring of additional heat source control (AHS)

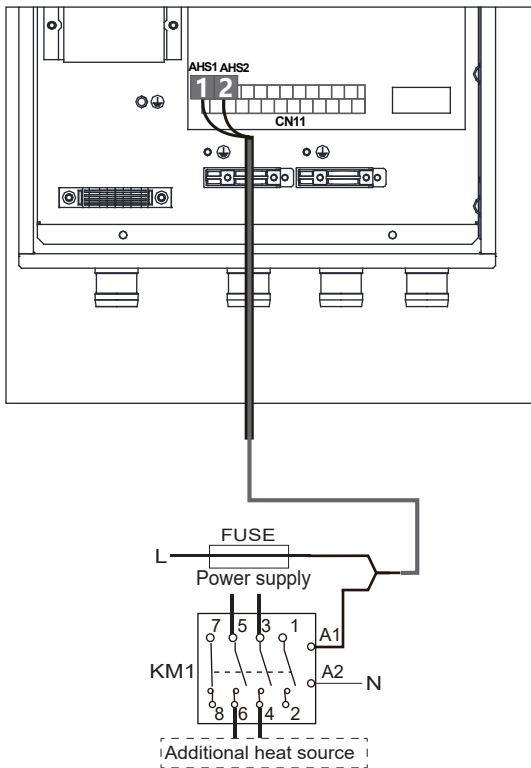

The wiring between the switch box and the back plate is shown in 7.5.2 Wiring of main power supply.

L-N Voltage	220-240VAC
Maximum running current (A)	0.2
Minimum wire size (mm ²)	0.75
Control port signal type	Type 1

NOTE

This part only applies to basic units (without a backup heater). For customized units (with a backup heater), the hydraulic module should not be connected to any additional heat source as there is an interval backup heater in the unit.

7.5.2 Wiring of 3-way valves SV1, SV2 and SV3

NOTE

Refer to the 3.9 Typical applications for the installation locations of SV1, SV2 and SV3.

SV1:

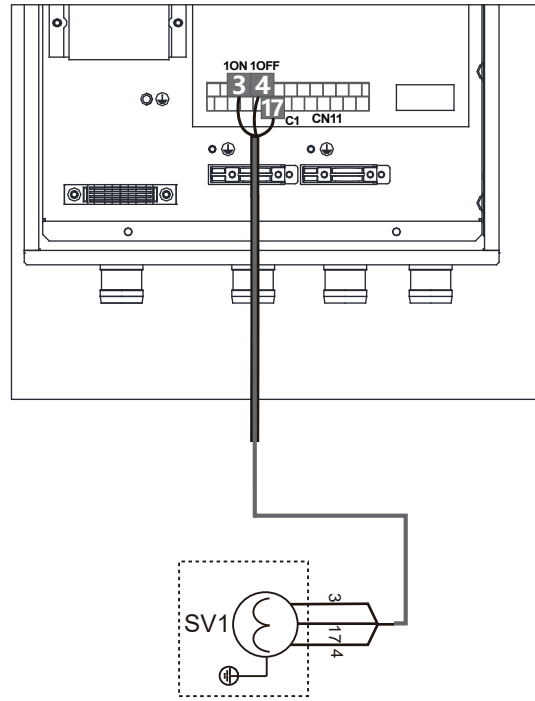

SV2:

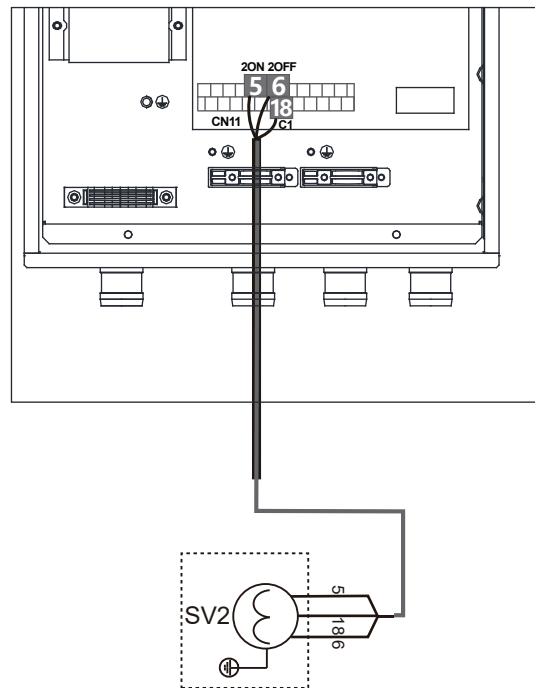

SV3:

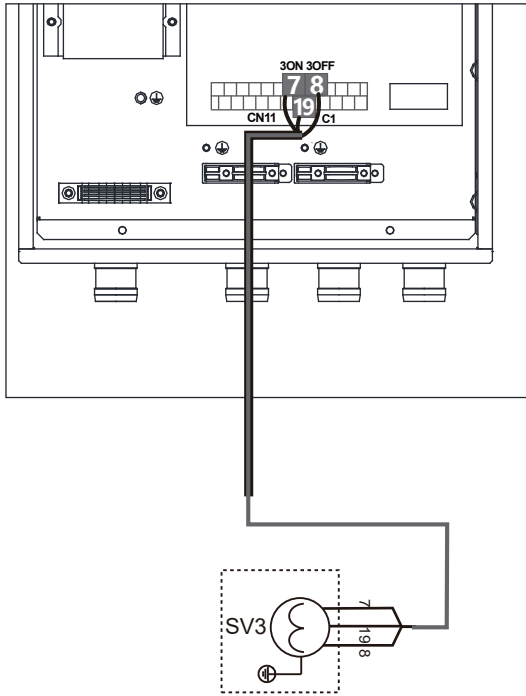

Voltage	220-240VAC
Maximum running current (A)	0.2
Minimum wire size (mm ²)	0.75
Control port signal type	Type 2

7.5.3 Wiring of additional pumps

Zone 2 pump P_c:

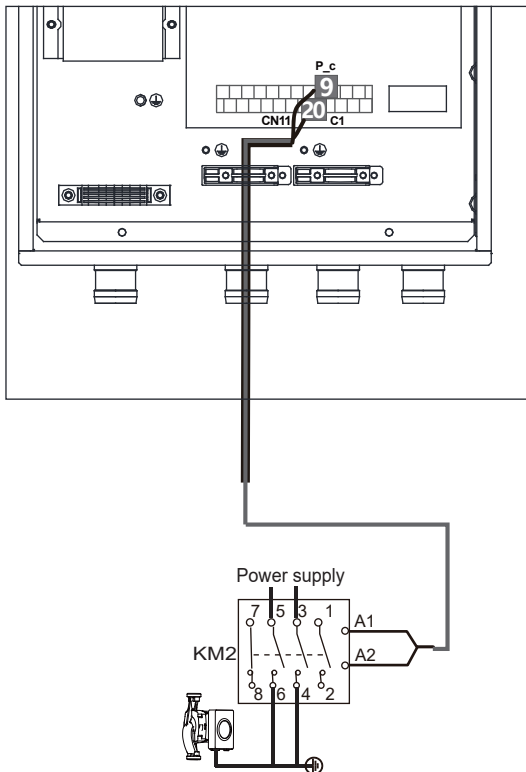

Additional circulation pump P_o:

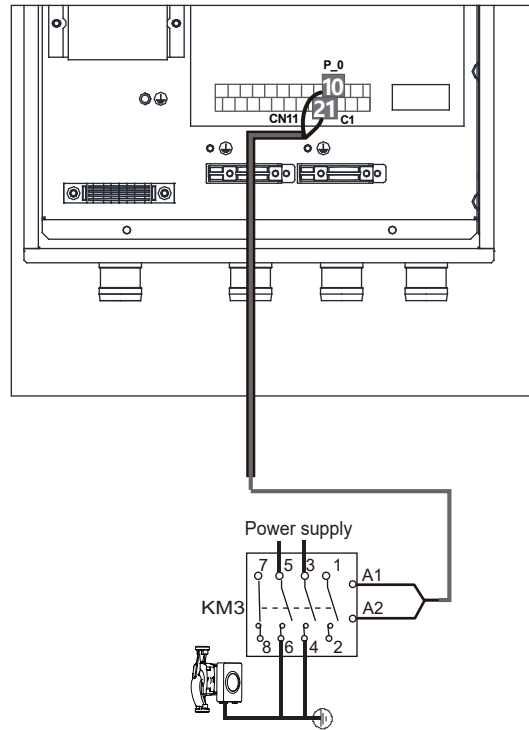

Solar energy pump P_s:

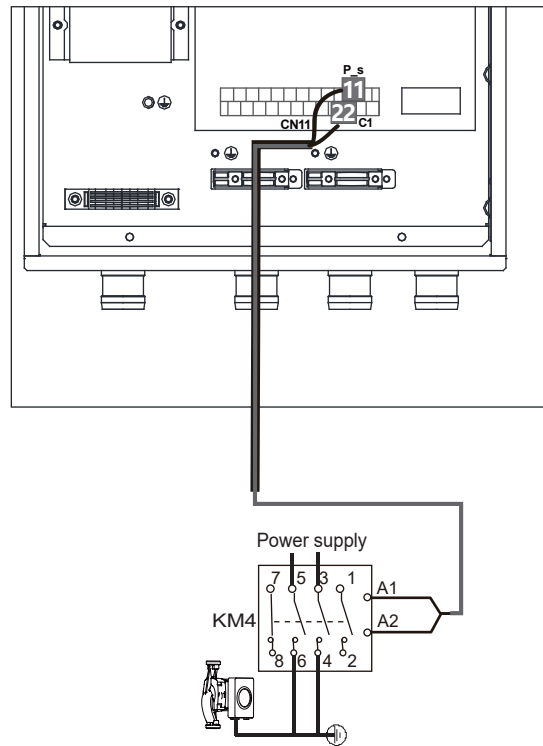

DHW pipe pump P_d:

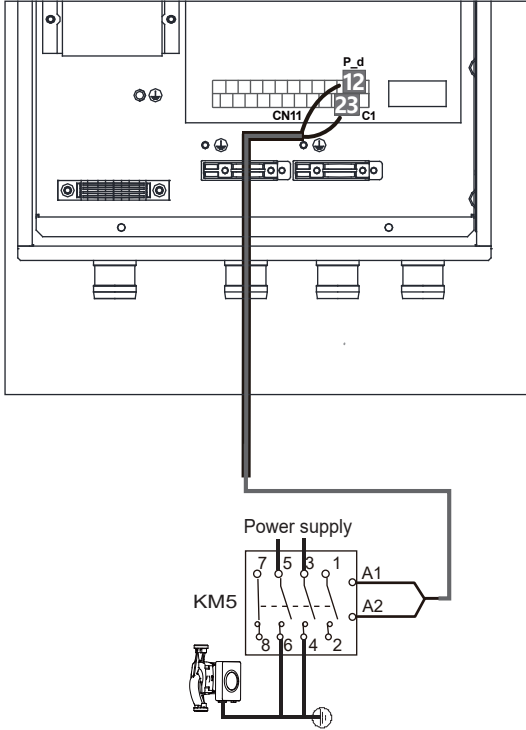

Voltage	220-240VAC
Maximum running current (A)	0.2
Minimum wire size (mm ²)	0.75
Control port signal type	Type 2

7.5.4 Wiring of alarm or defrost run (P_x)

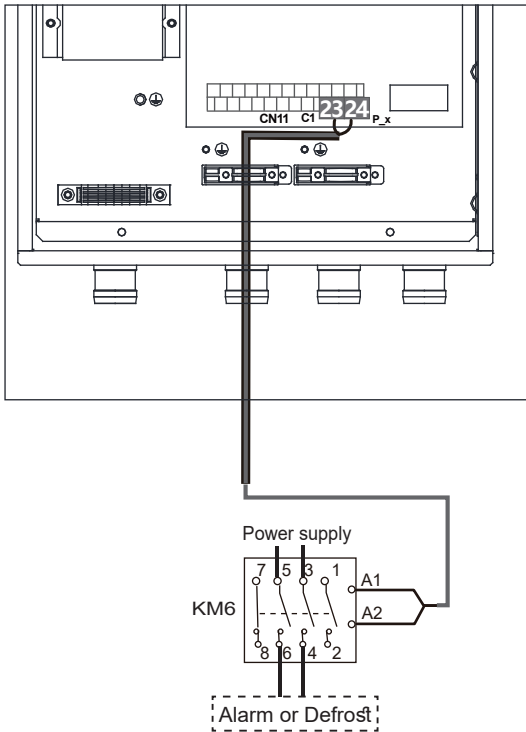

Voltage	220-240VAC
Maximum running current (A)	0.2
Minimum wire size (mm ²)	0.75
Control port signal type	Type 2

7.5.5 Wiring of tank booster heater (TBH)

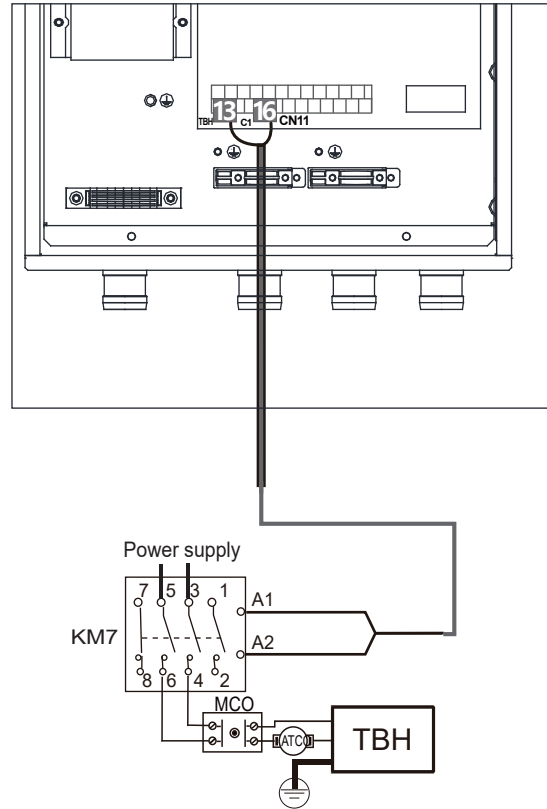

NOTE

MCO: Manual reset thermal protector
 ATC: Auto reset thermal protector

7.5.6 Wiring of external IBH

NOTE

- The unit only sends an ON/OFF signal to the heater.
- IBH cannot be wired independently.

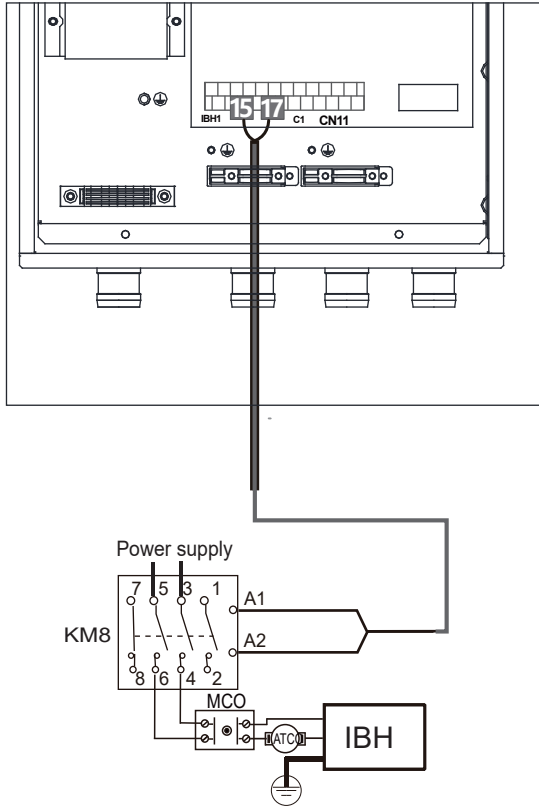

Voltage	220-240VAC
Maximum running current (A)	0.2
Minimum wire size (mm ²)	0.75
Control port signal type	Type 2

NOTE

MCO: Manual reset thermal protector
 ATC: Auto reset thermal protector

7.5.7 Wiring of room thermostat (RT)

Room thermostat (low voltage): "POWER IN" provides the voltage to the RT.

NOTE

The room thermostat must be low-voltage.

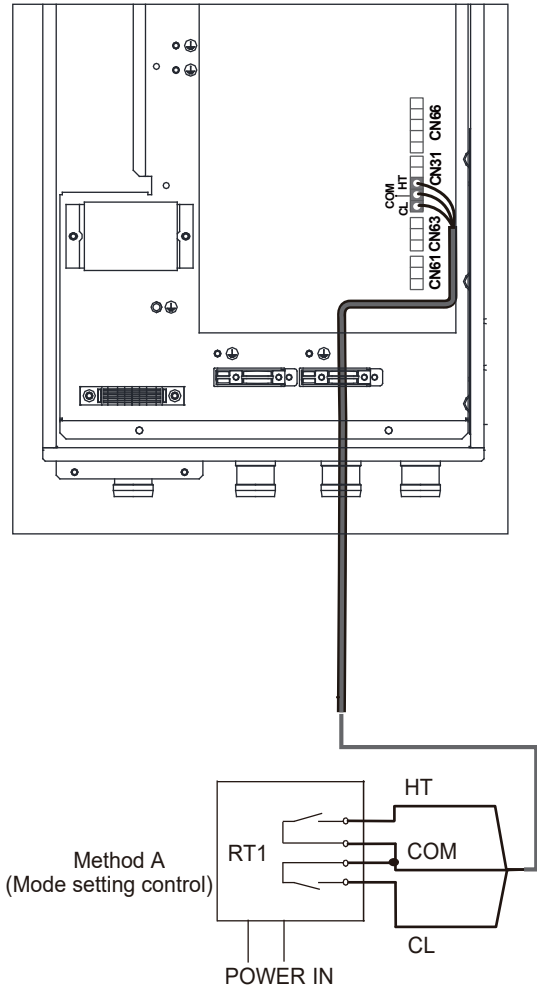

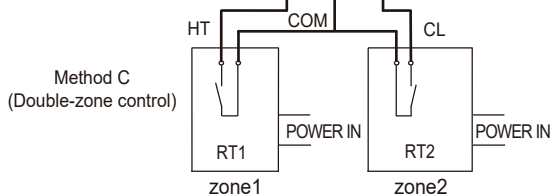
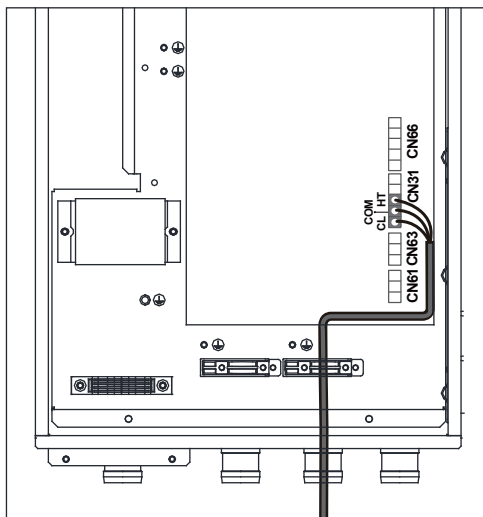
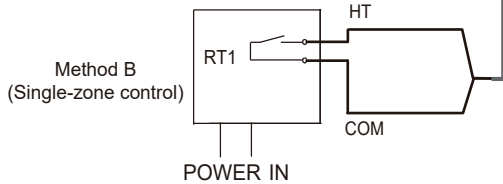
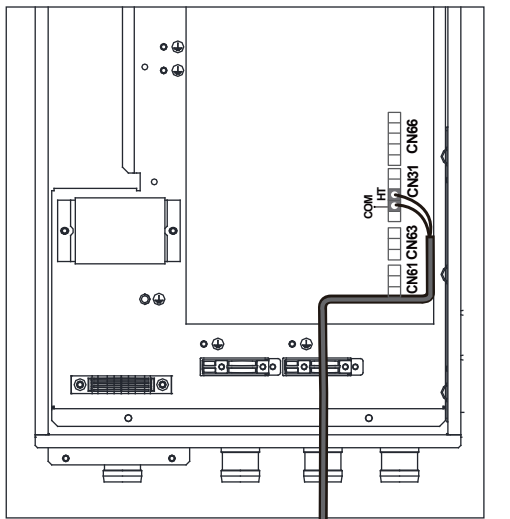

The thermostat cable can be connected in three ways (as described in the figures above) and the specific connection method depends on the application.

Method A (Mode setting control)

RT can control heating and cooling individually, like the controller for 4-pipe FCU. When the hydraulic module is connected with the external temperature controller, ROOM THERMOSTAT is set to MODE SET on the wired controller:

- A.1 When the unit detects a voltage of 230VAC between CL and COM, it operates in cooling mode.
- A.2 When the unit detects a voltage of 230VAC between HT and COM, it operates in heating mode.
- A.3 When the unit detects a voltage of 0VAC for both sides (CL-COM and HT-COM), it stops working for space heating or cooling.
- A.4 When the unit detects a voltage of 230VAC for both sides (CL-COM and HT-COM), it operates in cooling mode.

Method B (single-zone control)

RT provides the switch signal to the unit. ROOM THERMOSTAT is set to ONE ZONE on the wired controller:

- B.1 When the unit detects a voltage of 230VAC between HT and COM, it turns on.
- B.2 When the unit detects a voltage of 0VAC between HT and COM, it turns off.

Method C (double-zone control)

The hydraulic module is connected with two room thermostats, and ROOM THERMOSTAT is set to DOUBLE ZONE on the wired controller:

- C.1 When the unit detects a voltage of 230VAC between HT and COM, zone1 turns on. When the unit detects a voltage of 0VAC between HT and COM, zone1 turns off.
- C.2 When the unit detects a voltage of 230VAC between CL and COM, zone2 turns on according to the climate temp curve. When the unit detects a voltage of 0V between CL and COM, zone2 turns off.
- C.3 When the voltage between HT-COM and CL-COM is detected as 0VAC, the unit turns off.
- C.4 When the voltage between HT-COM and CL-COM is detected as 230VAC, both zone1 and zone2 turn on.

NOTE

- The wiring of the thermostat should correspond to the settings of the wired controller. Refer to 9.2 Configuration.
- Power supply of the device and room thermostat must be connected to the same neutral line.
- When ROOM THERMOSTAT is not set to NON, the indoor temperature sensor Ta cannot be set to VALID.
- Zone 2 can only operate in heating mode. When cooling mode is set on the wired controller and zone 1 is OFF, "CL" in Zone 2 closes, and system still remains 'OFF'. For installation, the wiring of thermostats for Zone 1 and Zone 2 must be correct.

7.5.8 Wiring of solar energy input signal (low voltage)

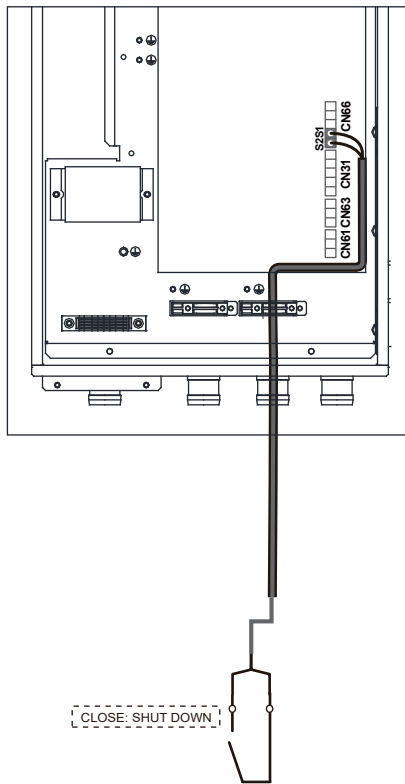

7.5.9 Wiring of remote shutdown

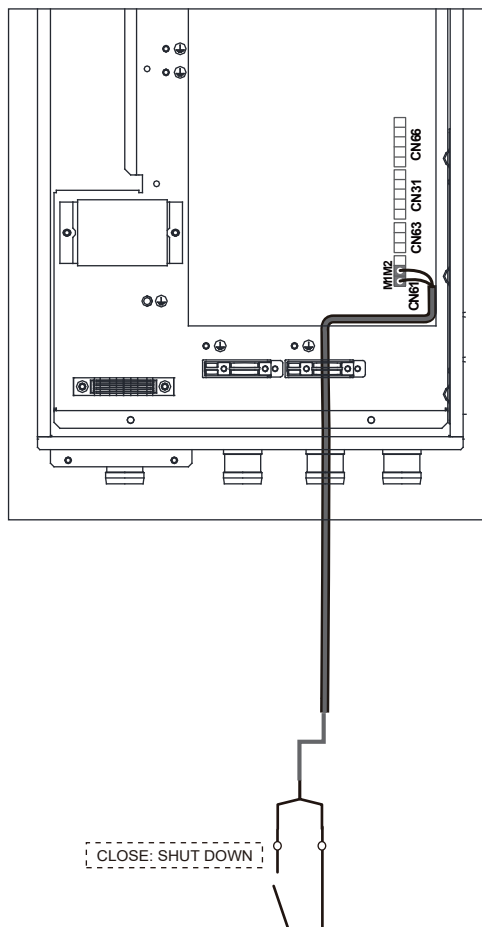

7.5.10 Wiring of smart grid

The unit has a smart grid feature, and there are two ports on the PCB to connect SG signals and EVU signals as below:

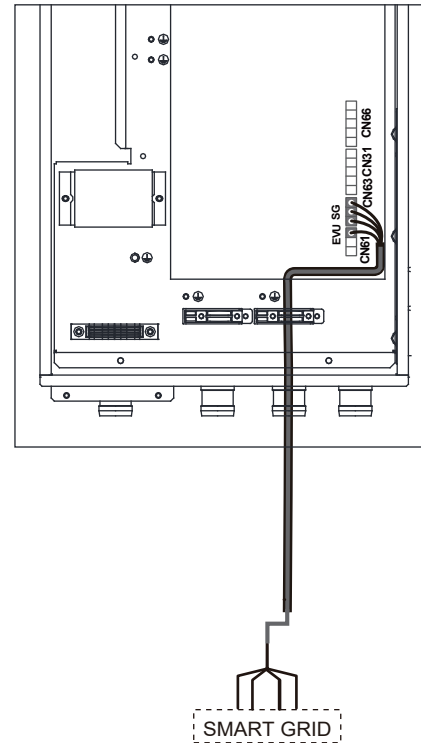

1) SG=ON, EVU=ON.

If DHW mode is set available:

- The heat pump will operate in DHW mode firstly.
- When TBH is set available, if T5 is lower than 69°C, the TBH will be turned on forcibly (The heat pump and TBH can operate at the same time.); if T5 is higher than or equal to 70°C, the TBH will be turned off. (DHW: Domestic Hot Water; T5S is the set temperature of the water tank.)
- When TBH is set unavailable and IBH is set available for DHW mode, if T5 is lower than 69°C, the IBH will be turned on forcibly (The heat pump and IBH can operate at the same time.); if T5 is higher than or equal to 70°C, the IBH will be turned off.

2) SG=OFF, EVU=ON.

If DHW mode is set available and DHW mode is set to ON:

- The heat pump will operate in DHW mode firstly.
- When TBH is set available and DHW mode is set ON, if T5 is lower than T5S-2, the TBH will be turned on (The heat pump and TBH can operate at the same time.); If T5 is higher than or equal to T5S+3, the TBH will be turned off.
- When TBH is set unavailable and IBH is set available for DHW mode, if T5 is lower than T5S-dT5_ON, the IBH will be turned on (The heat pump and IBH can operate at the same time.); If T5 is higher than or equal to Min (T5S+3,70), the IBH will be turned off.

3) SG=OFF, EVU=OFF.

The unit will operate properly.

4) SG=ON, EVU=OFF.

The heat pump, IBH, and TBH will be turned off immediately.

7.6 Cascade Function

See the INSTALLATION, OPERATION AND MAINTENANCE MANUAL.

7.7 Connection for Other Optional Components

7.7.1 Wiring of drainage pipe heating tape

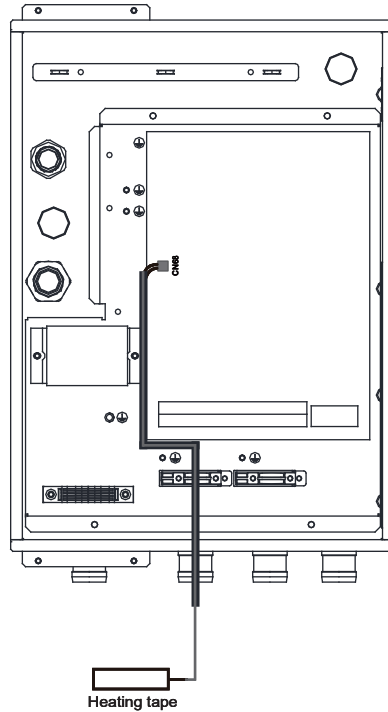

The maximum power is 100W.

NOTE

Use tie wraps

After wiring, the sleeve



should be fastened with a tie wrap (accessory)



8 INSTALLATION OF WIRED CONTROLLER

⚠ CAUTION

- The general instructions on wiring in previous chapters should be observed.
- The wired controller must be installed indoors and kept away from direct sunlight.
- Keep the wired controller away from any ignition source, flammable gas, oil, water vapor, and sulfide gas.
- To avoid electromagnetic disturbance, keep the wired controller at a proper distance from electric appliances, such as lamps.
 - The circuit of the remote wired controller is a low-voltage circuit. Never connect it with a standard 220V/380V circuit or place it into a same wiring tube with the circuit.
 - Use a terminal connection block to extend the signal wire if necessary.
 - Do not use a megger to check insulation of the signal wire upon completion of connection.

8.1 Materials for Installation

Verify that the accessory bag contains the following items:

No.	Name	Qty.	Remarks
1	Wired controller	1	_____
2	Round head screw, ST4 x 20	4	For mounting on a wall
3	Cross round head mounting screw	2	For mounting on an 86-type box
4	Phillips head screw, M4 x 25	2	For mounting on an 86-type box
5	Plastic support bar	4	For mounting on a wall

8.2 Dimensions

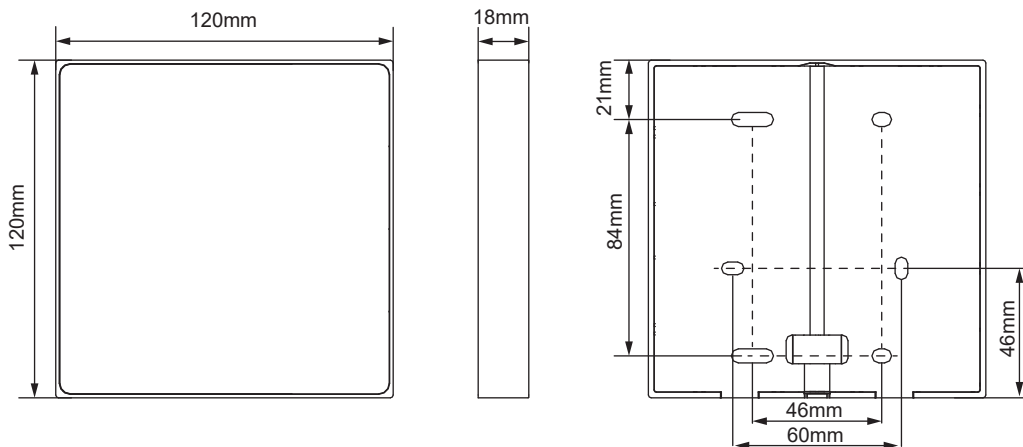

8.3 Wiring

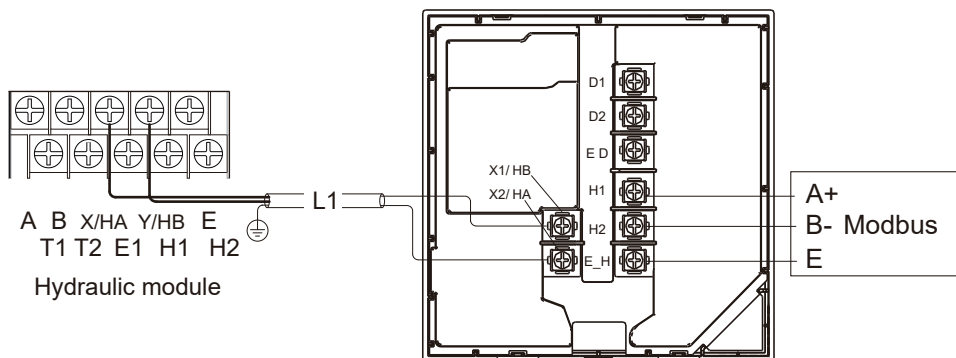

Input voltage (HA/HB)	18VDC
Wire size	0.75 mm ²
Wire type	2-core shielded twisted pair cable
Wire length	L1 < 50 m

The maximum length of the communication wire between the unit and the controller is 50 m.

Route

Bottom-side wiring out

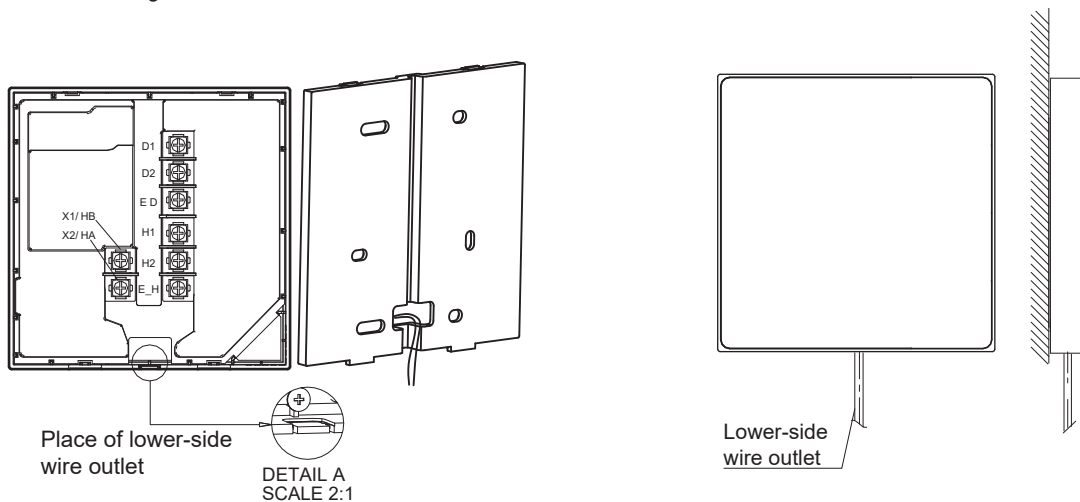

Inside wall wiring (with an 86-type box)

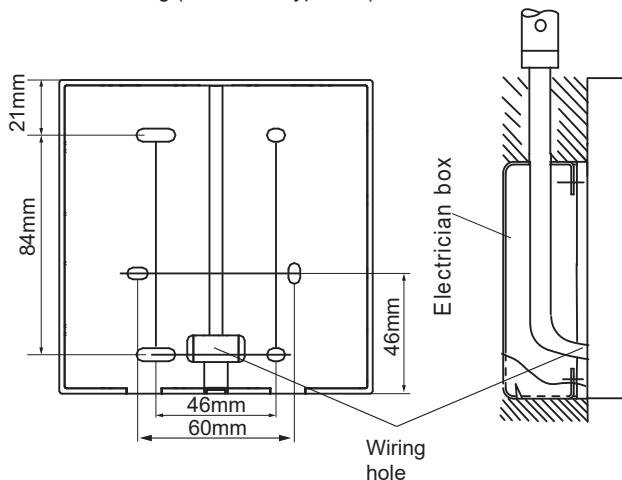

Inside wall wiring (without an 86-type box)

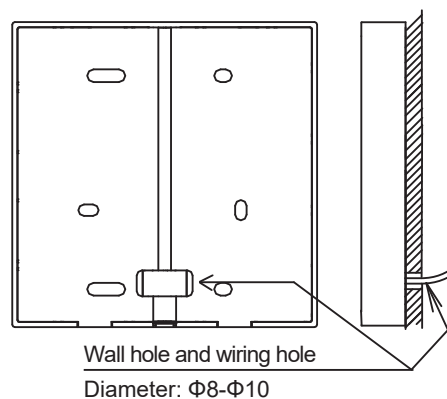

8.4 Mounting

NOTE

Only wall-mount the wired controller, instead of embedded, otherwise maintenance will not be possible.

Mounting on a wall (without an 86-type box)

Directly install the back cover on the wall with four ST4 x 20 screws.

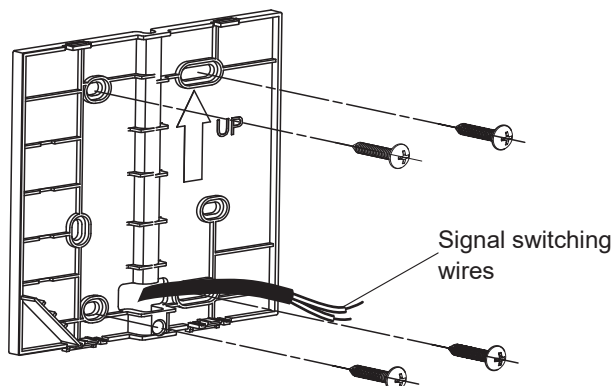

Mounting on a wall (with an 86-type box)

Install the back cover on an 86-type box with two M4 x 25 screws, and fixing the box on the wall with two ST4 x 20 screws.

- Adjust the length of the plastic bolt in the accessory box to make it suitable for installation.
- Fix the wired controller's bottom cover to the wall through the screw bar by using cross head screws. Make sure the bottom cover is set flush on the wall.

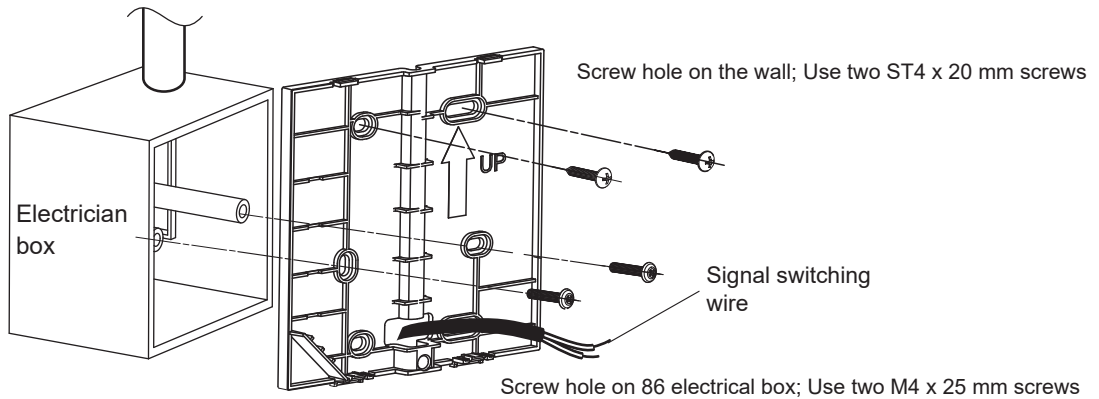

- Buckle the front cover, and fit the front cover to the back cover properly, leaving the wire unclamped during the installation.

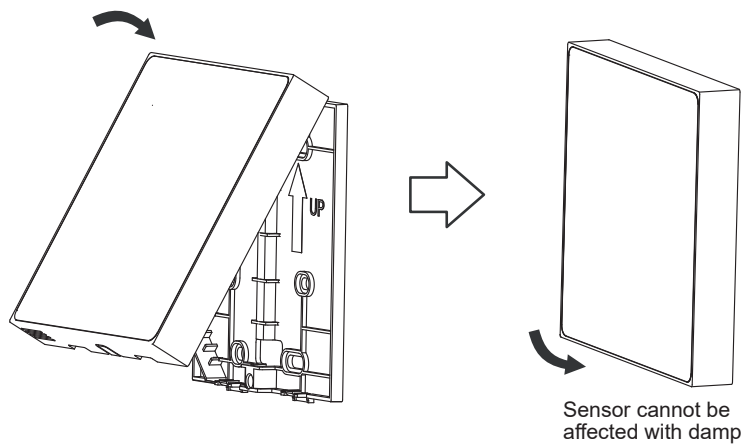

NOTE

To prevent water from entering the remote wired controller, use traps and plugs to seal the wire connections during wiring.

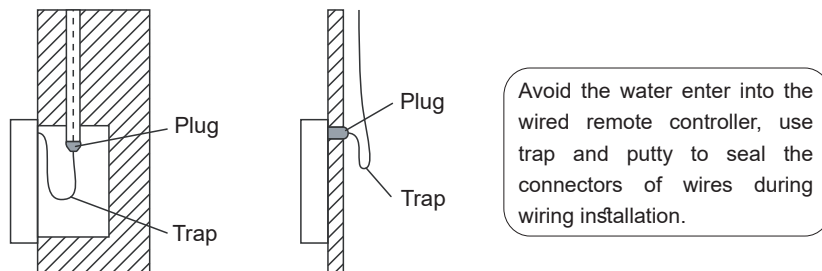

NOTE

Over-tightening the screw can cause deformation of the back cover.

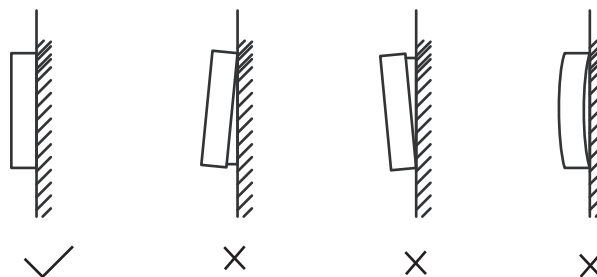

9 COMPLETION OF INSTALLATION

DANGER

Risk of electrocution.
Risk of burning.

Tightening torque	4.1 N•m
-------------------	---------

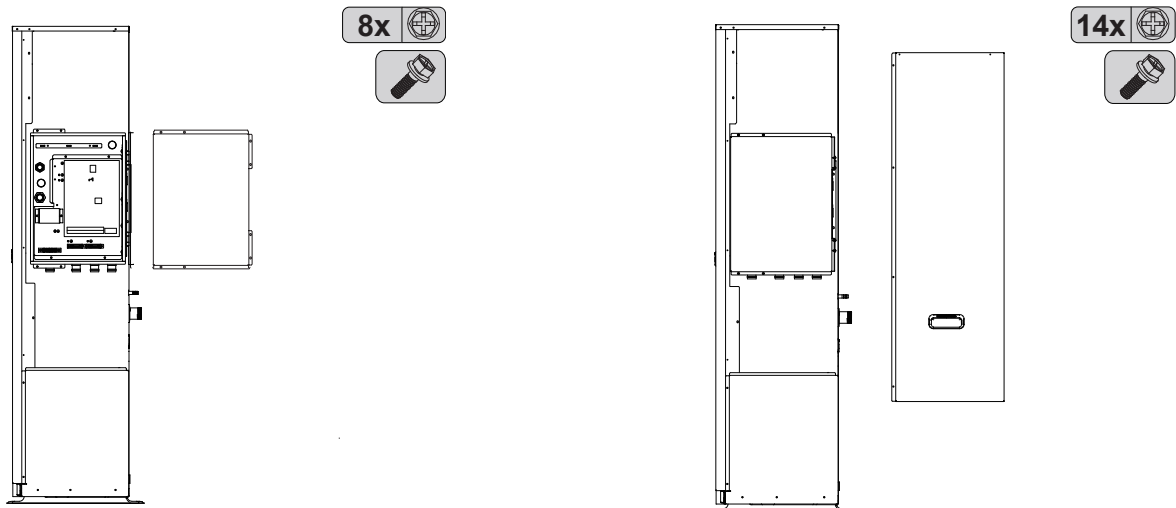

10 CONFIGURATION

The unit should be configured by an authorized installer to match the installation environment (outdoor climate, installed options, etc.) and meet the user demand.

Follow the instructions below for the next step.

10.1 Check Before Configuration

Before powering on the unit, check the following items:

<input type="checkbox"/>	Field wiring: Make sure all wiring connections observe the instructions mentioned in the 7. Electrical installation
<input type="checkbox"/>	Fuses, circuit breakers, or protection devices: Check the size and type according to the instructions mentioned in the 7.4 Electrical wiring guidelines. Make sure that no fuses or protection devices have been bypassed.
<input type="checkbox"/>	Backup heater's circuit breaker: Ensure the backup heater's circuit breaker in the switch box is closed (It varies with the backup heater type). Refer to the wiring diagram.
<input type="checkbox"/>	Booster heater's circuit breaker: Ensure the booster heater's circuit breaker is closed (applicable only to units with an optional domestic hot water tank).
<input type="checkbox"/>	Internal wiring: Check the wiring and connections inside the switch box for loose or damaged parts, including earth wiring.
<input type="checkbox"/>	Mounting: Check and ensure that the unit and the water loop system are properly mounted to avoid water leakage, abnormal noises and vibrations during the unit startup.
<input type="checkbox"/>	Damaged equipment: Check the components and piping inside the unit for any damage or deformation.
<input type="checkbox"/>	Refrigerant leak: Check the inside of the unit for any refrigerant leakage. In case of refrigerant leakage, follow the relevant content in the "Safety Precautions".
<input type="checkbox"/>	Power supply voltage: Check the voltage of the power supply. The voltage must be consistent with the voltage on the identification label of the unit.
<input type="checkbox"/>	Air vent valve: Make sure the air vent valve is open (at least 2 turns).
<input type="checkbox"/>	Shut-off valve: Make sure that the shut-off valve is fully open.
<input type="checkbox"/>	Sheet metal: Make sure all the sheet metal of the unit is mounted properly.

After powering on the unit, check the following items:

<input type="checkbox"/>	<p>Upon power-on of the unit, nothing is displayed on the wired controller: Check the following abnormalities before diagnosing possible error codes. - Wiring connection issue (power supply or communication signal). - Fuse failure on PCB.</p>
<input type="checkbox"/>	<p>Error code “E8” or “E0” is displayed on the wired controller: - Residual air exists in the system. - The water level in the system is insufficient. Before starting test run, make sure that the water system and the tank are filled with water, and air is removed. Otherwise, the pump or backup heater (optional) may be damaged.</p>
<input type="checkbox"/>	<p>Error code “E2” is displayed on the wired controller: - Check the wiring between the wired controller and the unit.</p>
<input type="checkbox"/>	<p>Initial start-up at low outdoor ambient temperature: To start the initial start-up in low outdoor ambient temperature, the water has to be heated gradually. Please use the preheating for floor function. (Refer to “SPECIAL FUNCTION” in FOR SERVICEMAN mode)</p>

NOTE

For underfloor heating application, floor could be damaged if the temperature rises sharply in a short time.
 Please ask the building construction contractor for further information.



About error code, see “13.3 Error codes”.

10.2 Configuration

To initialize the unit, a group of advanced settings should be provided by the installer. The advanced settings are accessible in FOR SERVICEMAN mode.

The overall parameters list of the advanced settings can be found in Annex 2. Operation Settings.

How to enter FOR SERVICEMAN mode

Press and hold  and  simultaneously for 3 seconds to enter the authorization page. Enter password 234 and confirm it. Then, the system jumps into the page with a list of advanced settings.

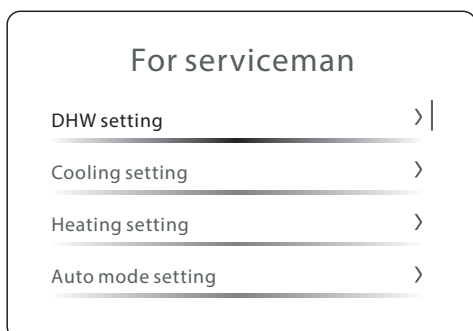
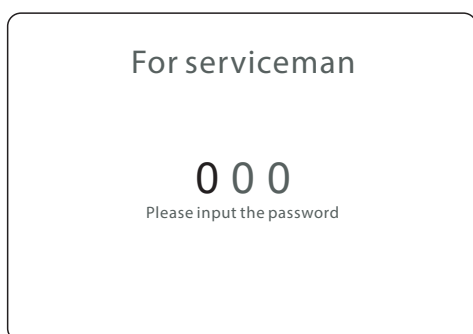

NOTE

“FOR SERVICEMAN” is only for installer or other specialist with sufficient knowledge and skills. The end user who use “FOR SERVICEMAN” is regarded as improper use.

Save the settings and quit FOR SERVICEMAN mode

After all settings are adjusted, press , and the confirmation page pops out. Select Yes and confirm to quit FOR SERVICEMAN mode.

NOTE

- The settings are saved automatically after you quit FOR SERVICEMAN mode.
- Temperature values displayed on the wired controller are measured in °C.

11 COMMISSIONING

Test run is used to confirm the operation of the valves, air purge, circulation pump operation, cooling, heating and domestic water heating.

Test run

Point check	>
Air purge	>
Circulated pump running	>
Cooling running	>

Test run

Heating running	>
Cooling running	>
DHW running	>

Checklist during commissioning

<input type="checkbox"/>	Test run for the actuator.
<input type="checkbox"/>	Air purge
<input type="checkbox"/>	Test run for operation.
<input type="checkbox"/>	Check of the minimum flow rate in all conditions.

11.1 Test Run for the Actuator

NOTE

During the commissioning of the actuator, the protection function of the unit is disabled. Excessive use may damage components.

Why

Check whether each actuator is in good working conditions.

What - Actuator List

No.	Name		Note
1	SV2	Three-way valve 2	
2	SV3	Three-way valve 3	
3	Pump_I	Integrated pump	
4	Pump_O	Outside pump	
5	Pump_C	Zone 2 pump	
6	IBH	Internal backup heater	
7	AHS	Additional heat source	
8	SV1	Three-way valve 1	Invisible if DHW is disabled
9	Pump_D	Circulation pump for DHW	Invisible if DHW is disabled
10	Pump_S	Solar pump	Invisible if DHW is disabled
11	TBH	Tank backup heater	Invisible if DHW is disabled

How

1	Go to "FOR SERVICEMAN" (Refer to 10.2 Configuration).
2	Find "Test run" and enter the process.
3	Find "Point check" and enter the process.
4	Select the actuator, and press <input type="radio"/> to activate or deactivate the actuator. <ul style="list-style-type: none"> • The status ON means the actuator is activated, and OFF means the actuator is deactivated.

NOTE

When you return to the upper layer, all actuators turn OFF automatically.

11.2 Air Purge

Why

To purge out the remaining air in the water loop.

How

1	Go to "FOR SERVICEMAN" (Refer to 10.2 Configuration).
2	Find "Test run and enter the process.
3	Find "Air purge" and enter the process.
4	Select "Air purge" and press <input type="radio"/> to activate or deactivate the air purge function. <ul style="list-style-type: none"> • <input checked="" type="radio"/> means the air purge function is activated, and <input type="radio"/> means the air purge function is deactivated.

Besides

"Air vent pump_i output"	To set pump_i output. The higher the value is, the pump gives a higher output.
"Air vent running time"	To set the duration of air purge. When the set time is due, air purge is deactivated.
"Status check"	Additional operation parameters can be found.

11.3 Test Run

Why

Check whether the unit is in good working conditions.

What

Circulated pump operation

Cooling operation

Heating operation

DHW operation

How

1	Go to "FOR SERVICEMAN" (Refer to 10.2 Configuration)
2	Find "Test run" and enter the page.
3	Find "Other" and enter the process.
4	Select "XXXX"* and press <input type="radio"/> to run the test. During test, press <input type="radio"/> , select OK and confirm to return to the upper layer. * - Four performance test options are shown in What .

NOTE

In performance test, the target temperature is preset and cannot be changed.

If the outdoor temperature is outside the range of operating temperature, the unit may not operate or may not deliver the required capacity.

In circulated pump operation, If the flow rate is out of recommended flow rate range, please make proper change of the installation, and ensure that the flow rate in the installation is guaranteed in all conditions.

11.4 Check of the Minimum Flow Rate

1	Check the hydraulic configuration to find out the space heating loops that can be closed by mechanical, electronic, or other valves.
2	Close all space heating loops that can be closed.
3	Start and operate the circulation pump (See "11.3 Test Run").
4	Read out the flow rate ^(a) and modify the bypass valve settings until the set value reaches the minimum flow rate required + 2 l/min.

(a) During pump trail run, the unit can operate below the minimum required flow rate.

12 HAND-OVER TO THE USER

- Make sure that the user has the printed documentation and ask the user to keep it for future reference.
- Empty the error history in the HMI before hand-over to the user.
- It is highly recommended to do the WLAN connection of the unit. You can read more information in the APP.
- Explain to the user how to properly operate the system and what to do in case of problems.
- Show the user what to do for the maintenance of the unit. (For the maintenance, refer to the INSTALLATION, OPERATION AND MAINTENANCE MANUAL)
- Explain to the user about energy saving tips. (Refer to the INSTALLATION, OPERATION AND MAINTENANCE MANUAL)

13 MAINTENANCE

Regular checks and inspections at certain intervals are required to guarantee the optimal performance of the unit.

13.1 Safety Precautions for Maintenance

⚠ DANGER

Risk of electrocution.

⚠ WARNING

- Please note that some parts of the electric component box are hot.
- Do not rinse the unit. Otherwise, electric shock or fire may occur.
- Do not leave the unit unattended when the service panel is removed.

💡 NOTE

Before performing any maintenance or service work, touch a metal part of the unit to eliminate static electricity and to protect the PCB.

13.2 Annual Maintenance

13.2.1 Water pressure

Check the water pressure. If it is below 1 bar, fill the system with more water.

13.2.2 Water strainer

Clean the water strainer.

13.2.3 Water pressure relief valve

-Check for correct operation of the pressure relief valve by turning the black knob on the valve counterclockwise:
-If no clacking sound is heard, contact the local dealer.
-In case the water keeps running out of the unit, close the shut-off valves at both the water inlet and outlet, and then contact the local dealer.

13.2.4 Pressure relief valve hose

Verify that the pressure relief valve hose is positioned appropriately to drain the water.

13.2.5 Insulation cover of backup heater

Verify that the insulation cover of the backup heater is fastened tightly around the backup heater vessel.

13.2.6 Pressure relief valve of domestic hot water tank (supplied by the user)

Applicable only to installations with a domestic hot water tank. Check for correct operation of the pressure relief valve on the domestic hot water tank.

13.2.7 Booster heater of domestic hot water tank

Applicable only to installations with a domestic hot water tank. Remove the scale buildup from the booster heater, especially in regions with hard water. Drain the domestic hot water tank, remove the booster heater from the domestic hot water tank, and dissolve the scale with specific descaling agent.

13.2.8 Switch box of the unit

- Visually inspect the switch box and look for obvious defects such as loose connections or defective wiring.

- Verify that cabling will not be subject to wear, corrosion, excessive pressure, vibration, sharp edges or any other adverse environmental effects. Take into account the effects of aging or continual vibration from sources such as compressors or fans.

- Check for correct operation of contactors with an ohmmeter. All contacts of these contactors must be in open position.

13.2.9 Temperature sensor

Check the resistance of each temperature sensor with an ohmmeter.

💡 NOTE

As the connector is small, use thin probes.

- Refer to 2.8.4 Control board for the socket of each temperature sensor, and unplug the connector.
- Check the resistance with an ohmmeter.
- Compare the read value with that in the resistance characteristics table. The temperature sensor is in good conditions if the deviation is within tolerance.

For the temperature sensor in accessories and temperature sensors on the water loop, e.g. TW_in and TW_out, refer to Table 3-1.

13.2.10 Use of antifreeze

- The "safety precautions" must be observed.
- Make sure that the glycol solution disposed in accordance with local regulations and standards.

13.2.11 Refrigerant leakage check

Refer to 15.2. Leak Detection Methods.

13.2.12 Flow switch failure

Water may enter the flow switch and may freeze when the temperature is too low. In such a case, the flow switch should be removed and dried before being installed in the unit. Before removal of the flow switch, the water in the system should be drained.

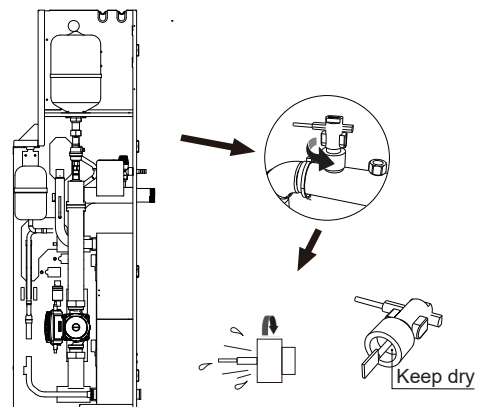

- Rotate the flow switch counterclockwise to remove it.
- Dry the flow switch completely.

14. TECHNICAL DATA

14.1 General

Model	3-phase	3-phase	3-phase
	26 kW	30 kW	35 kW
Nominal capacity	Refer to the Technical Data		
Dimensions H×W×D	1816×1384×523 mm		
Packing dimensions H×W×D	2000×1480×570 mm		
Weight			
Net weight	260 kg		
Gross weight	285 kg		
Connections			
Water inlet/outlet	G1 1/4"BSP		
Water drain	Hose nipple		
Expansion vessel			
Volume	4.5 L		
Maximum working pressure (MWP)	8 bar		
Pump			
Type	Water cooled		
No. of speed	Variable speed		
Pressure relief valve in water loop	3 bar		
Operation range - water side			
Heating	+25 to +85°C		
Cooling	0 to +25°C		
Operation range - air side			
Heating	-25 to 43°C		
Cooling	-15 to 48°C		
Domestic hot water by heat pump	-25 to 43°C		
Refrigerant			
Refrigerant type	R290		
Refrigerant charge	2.9 kg		
Fuse – on PCB			
PCB name	Main control board	Fan inverter board	
Model name	FUSE-T-10A/250VAC-T-P	FUSE-T-6.3A/500VAC-T/S	
Working voltage (V)	250	500	
Working current (A)	10	6.3	
Fuse – on Drive electronic control box			
Model name	FUSE-T-63A/690VAC-T/S		
Working voltage (V)	690		
Working current (A)	63		

14.2 Piping Diagram

26-35 kW units (standard)

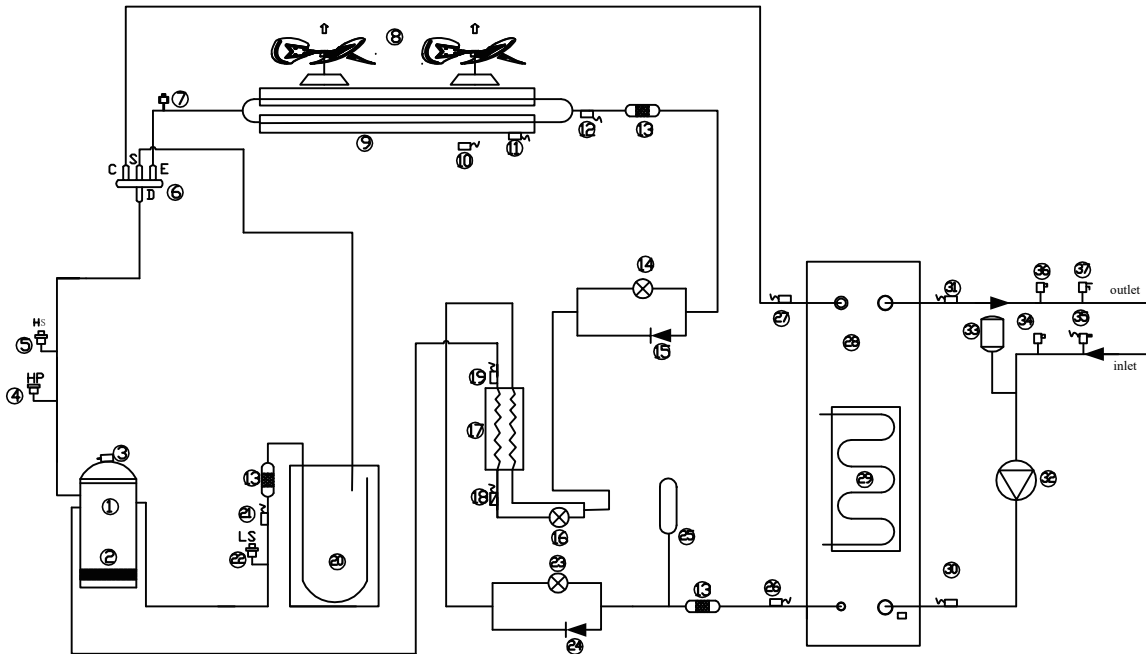

Item	Description	Item	Description
1	DC inverter compressor	20	Vapor-liquid separator
2	Crankcase heater	21	Temperature sensor (compressor suction)
3	Discharge temperature sensor	22	Low pressure sensor
4	High pressure switch	23	Cooling Electronic expansion valve
5	High pressure sensor	24	One-way valve
6	4-way valve	25	Liquid reservoir
7	Pin valve (Discharge side)	26	Temperature sensor (plate heat exchanger inlet refrigerant: cooling)
8	DC fan 1 /DC fan 2	27	Temperature sensor (plate heat exchanger outlet refrigerant: cooling)
9	Condenser	28	Plate heat exchanger
10	Suction temperature sensor	29	Heat tape (plate heat exchanger)
11	Temperature sensor (heat exchanger)	30	Temperature sensor (water inlet)
12	Temperature sensor (heat exchanger outlet refrigerant: cooling)	31	Temperature sensor (water outlet)
13	Filter	32	Water pump
14	Heating Electronic expansion valve	33	Expansion vessel
15	One-way valve	34	Automatic air vent valve
16	EVI Electronic expansion valve	35	Water flow switch
17	Plate heat exchanger (Economizer)	36	Automatic air vent valve
18	Economizer inlet temperature sensor	37	Safety valve
19	Economizer outlet temperature sensor		

ANNEX

Annex 1. Menu Structure (Wired Controller)

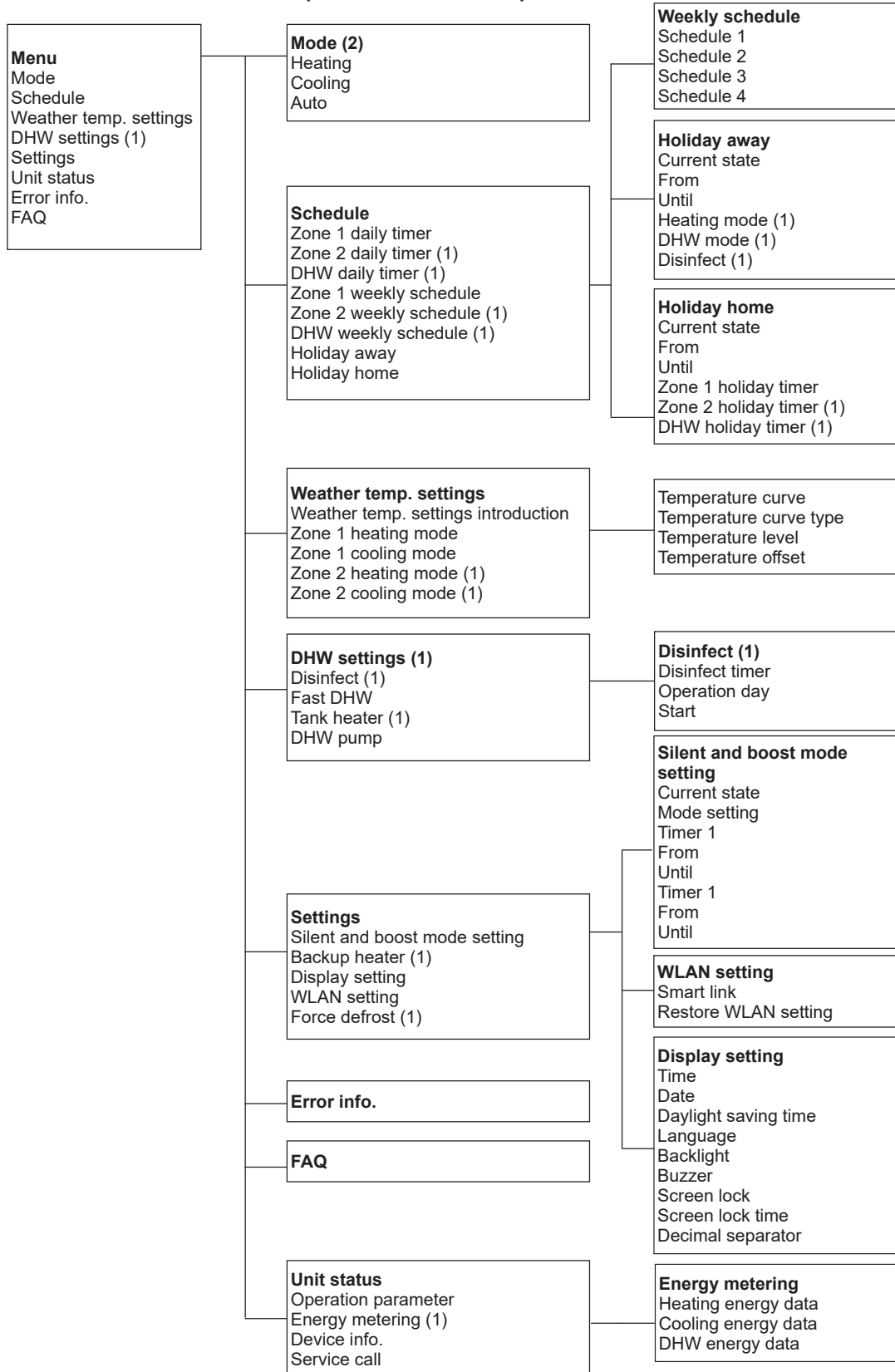

(1) Invisible if corresponding function is disabled.

(2) The layout could be different if the corresponding function is disabled or enabled.

There are also some other items that are invisible if the function is disabled or unavailable.

For serviceman

For serviceman

- 1 DHW setting
- 2 Cooling setting
- 3 Heating setting
- 4 Auto mode setting
- 5 Temp. type setting
- 6 Room thermostat setting
- 7 Other heating source
- 8 Holiday away setting
- 9 Service call
- 10 Restore factory setting
- 11 Test run
- 12 Special function
- 13 Auto restart
- 14 Power input limitation
- 15 Input define
- 16 Cascade setting
- 17 HMI address setting
- 18 Common setting

1 DHW setting

- 1.1 DHW mode
- 1.2 Disinfect
- 1.3 DHW priority
- 1.4 Pump_D
- 1.5 DHW priority time set
- 1.6 dt5_ON
- 1.7 dt1S5
- 1.8 T4DHWMAX
- 1.9 T4DHWMIN
- 1.10 t_INTERVAL_DHW
- 1.11 T5S_DISINFECT
- 1.12 t_DI_HIGHTEMP
- 1.13 t_DI_MAX
- 1.14 t_DHWHP_RESTRICT
- 1.15 t_DHWHP_MAX
- 1.16 PUMP_D TIMER
- 1.17 PUMP_D RUNNING TIME
- 1.18 PUMP_D DISINFECT
- 1.19 ACS function

2 Cooling setting

- 2.1 Cooling mode
- 2.2 t_T4_FRESH_C
- 2.3 T4CMAX
- 2.4 T4CMIN
- 2.5 dt1SC
- 2.6 dtSC
- 2.7 t_INTERVAL_C
- 2.8 ZONE1 C-emission
- 2.9 ZONE2 C-emission

3 Heating setting

- 3.1 Heating mode
- 3.2 t_T4_FRESH_H
- 3.3 T4HMAX
- 3.4 T4HMIN
- 3.5 dt1S H
- 3.6 dtSH
- 3.7 t_INTERVAL_H
- 3.8 ZONE1 H-emission
- 3.9 ZONE2 H-emission
- 3.10 Force defrost

4 Auto mode setting

- 4.1 T4AUTOCMIN
- 4.2 T4AUTOHMAX

5 Temp. type setting

- 5.1 Water flow temp.
- 5.2 Room temp.
- 5.3 Double zone

6 Room thermostat setting

- 6.1 Room thermostat
- 6.2 Mode set priority

17 HMI address setting

- 17.1 HMI setting
- 17.2 HMI address for BMS
- 17.3 Stop BIT

18 Common setting

- 18.1 t_DELAY PUMP
- 18.2 t1_ANTILOCK PUMP
- 18.3 t2_ANTILOCK PUMP RUN
- 18.4 t1_ANTILOCK SV
- 18.5 t2_ANTILOCK SV RUN
- 18.6 Ta_adj.
- 18.7 F-PIPE LENGTH
- 18.8 PUMP_I SILENT OUTPUT
- 18.9 Energy metering
- 18.10 Pump_O

19 Clear energy data

20 Intelligent function settings

- 20.1 Energy correction

21 C2 fault restore

7 Other heating source

- 7.1 IBH function
- 7.2 IBH locate
- 7.3 dt1_IBH_ON
- 7.4 t_IBH_DELAY
- 7.5 T4_IBH_ON
- 7.6 P_IBH1
- 7.7 P_IBH2
- 7.8 AHS function
- 7.9 AHS_PUMPI CONTROL
- 7.10 dt1_AHS_ON
- 7.11 t_AHS_DELAY
- 7.12 T4_AHS_ON
- 7.13 EnSwitchPDC
- 7.14 GAS_COST
- 7.15 ELE_COST
- 7.16 MAX_SETHEATER
- 7.17 MIN_SETHEATER
- 7.18 MAX_SIGHEATER
- 7.19 MIN_SIGHEATER
- 7.20 TBH FUNCTION
- 7.21 dt5_TBH_OFF
- 7.22 t_TBH_DELAY
- 7.23 T4_TBH_ON
- 7.24 P_TBH
- 7.25 SOLAR function
- 7.26 SOLAR control
- 7.27 Deltasol

8 Holiday away setting

- 8.1 T1S_H.A._H
- 8.2 T5S_H.A._DHW

9 Service call

- Phone number
- Mobile number

10 Restore factory setting

11 Test run

12 Special function

- 12.1 Preheating for floor
- 12.2 Floor drying up

13 Auto restart

- 13.1 Auto restart cooling/heating mode
- 13.2 Auto restart DHW mode

14 Power input limitation

- 14.1 Power input limitation

15 Input define

- 15.1 M1M2
- 15.2 Smart grid
- 15.3 T1T2
- 15.4 Tbt
- 15.5 P_X PORT

16 Cascade setting

- 16.1 PER_START
- 16.2 TIME_ADJUST

There are some items that are invisible if the function is disabled or unavailable.

Annex 2. User Settings Parameters

No.	Code	Definition	Default	Minimum	Maximum	Setting interval	Unit	
6.1 Mode & Temperature set								
Mode	Operation mode	Operation mode setting 1=Auto, 2=Cooling, 3=Heating	3	1	3	/	/	
Temperature set	T1S	Water outlet temperature (Zone 1)	For FCU cooling	12	5	25	1	°C
			For FLH / RAD cooling	23	18	25	1	°C
			For FLH heating	30	25	55	1	°C
			For FCU / RAD heating	40	35	85	1	°C
	T1S2	Water outlet set temperature (Zone 2)	For FCU cooling	12	5	25	1	°C
			For FLH / RAD cooling	23	18	25	1	°C
			For FLH heating	30	25	55	1	°C
	TS	Room set temperature Ta	Cooling	24	17	30	0.5	°C
			Heating	24	17	30	0.5	°C
			AUTO	24	17	30	0.5	°C
T5S (DHW MODE=Yes)	DHW set temperature	50	20	75	1	°C		
6.2 Schedule								
Zone 1 daily timer	TIMER1-TIMER6	Enablement 0=inactive, 1=active	0	0	1	1	/	
	TIMER1-TIMER6 Time	Timer start time	00:00	00:00	23:50	1/10	h/min	
	TIMER1-TIMER6 Mode	Operation mode of the timer 2=Cooling, 1=Heating, 0=OFF	0	0	2	1	/	
	TIMER1-TIMER6 Temp.	Set temperature of the timer	For FCU cooling	12	5	25	1	°C
			For FLH / RAD cooling	23	18	25	1	°C
			For FLH heating	30	25	55	1	°C
			For FCU / RAD heating	40	35	85	1	°C
			Room heating set temperature Ta	24	17	30	0.5	°C
			Room cooling set temperature Ta	24	17	30	0.5	°C
	Zone 2 daily timer	TIMER1-TIMER6	Enablement 0=inactive, 1=active	0	0	1	1	/
TIMER1-TIMER6 Time		Timer start time	00:00	00:00	23:50	1/10	h/min	
TIMER1-TIMER6 Mode		Operation mode of the timer 2=Cooling, 1=Heating, 0=OFF	0	0	2	1	/	
TIMER1-TIMER6 Temp.		Set temperature of the timer	For FCU cooling	12	5	25	1	°C
			For FLH / RAD cooling	23	18	25	1	°C
			For FLH heating	30	25	55	1	°C
			For FCU / RAD heating	40	35	85	1	°C
			Room heating set temperature Ta	24	17	30	0.5	°C
			Room cooling set temperature Ta	24	17	30	0.5	°C
DHW daily timer		TIMER1-TIMER6	Enablement 0=inactive, 1=active	0	0	1	1	/
	TIMER1-TIMER6 Time	Timer start time	00:00	00:00	23:50	1/10	h/min	
	TIMER1-TIMER6 DHW	Operation mode of the timer 1=DHW 0=OFF	0	0	1	1	/	
	TIMER1-TIMER6 Temp.	Set temperature of the timer	50	20	75	1	/	
Zone 1 weekly schedule	Schedule1 - Schedule4	Enablement 0=inactive, 1=active	0	0	1	1	/	
	Schedule1 - Schedule4 Day	Enablement 0=inactive, 1=active (if all the date is active, then display 'Every day')	0	0	1	1	/	
	Command1-Command4	Enablement	0	0	1	1	/	
	Command1-Command4 Time	Timer start time	00:00	00:00	23:50	1/10	h/min	
	Command1-Command4 Mode	Operation mode of the timer 2=Cooling, 1=Heating, 0=OFF	0	0	2	1	/	
	Command1-Command4 Temp.	Set temperature of the timer	For FCU cooling	12	5	25	1	°C
			For FLH / RAD cooling	23	18	25	1	°C
			For FLH heating	30	25	55	1	°C
For FCU / RAD heating			40	35	85	1	°C	
		Room heating set temperature Ta	24	17	30	0.5	°C	
		Room cooling set temperature Ta	24	17	30	0.5	°C	

Zone 2 weekly schedule	Schedule1 - Schedule4	Enablement 0=inactive, 1=active	0	0	1	1	/	
	Schedule1 - Schedule4 Day	Enablement 0=inactive, 1=active (if all the date is active, then display 'Every day')	0	0	1	1	/	
	Command1-Command4	Enablement 0=inactive, 1=active	0	0	1	1	/	
	Command1-Command4 Time	Timer start time	00:00	00:00	23:50	1/10	h/min	
	Command1-Command4 Mode	Operation mode of the timer 2=Cooling, 1=Heating, 0=OFF	0	0	2	1	/	
	Command1-Command4 Temp.	Set temperature of the timer	For FCU cooling	12	5	25	1	°C
			For FLH / RAD cooling	23	18	25	1	°C
			For FLH heating	30	25	55	1	°C
			For FCU / RAD heating	40	35	85	1	°C
			Room heating set temperature Ta	24	17	30	0.5	°C
Room cooling set temperature Ta	24	17	30	0.5	°C			
DHW weekly schedule	Schedule1 - Schedule4	Enablement 0=inactive, 1=active	0	0	1	1	/	
	Schedule1 - Schedule4 Day	Enablement 0=inactive, 1=active (if all the date is active, then display 'Every day')	0	0	1	1	/	
	Command1-Command4	Enablement 0=inactive, 1=active	0	0	1	1	/	
	Command1-Command4 Time	Timer start time	00:00	00:00	23:50	1/10	h/min	
	Command1-Command4 DHW	Operation mode of the timer 2=Cooling, 1=Heating, 0=OFF	0	0	1	1	/	
	Command1-Command4 Temp.	Set temperature of the timer	50	20	75	1	/	
	Holiday away	Current state	Enablement 0=inactive, 1=active	0	0	1	1	/
From		Timer start date	Current date +1	Current date +1	12/31/2099	1/1/1	d/m/y	
Until		Timer end date	Current date +1	Current date +1	12/31/2099	1/1/1	d/m/y	
Heating mode		Enablement 0=inactive, 1=active	1	0	1	1	/	
Heating temp.		Set temperature of Holiday away	25	20	25	1	°C	
DHW mode		Enablement 0=inactive, 1=active	1	0	1	1	/	
DHW temp.		Set temperature of Holiday away	25	20	25	1	°C	
Disinfect		Enablement 0=inactive, 1=active	1	0	1	1	/	
Holiday home	Current state	Enablement 0=inactive, 1=active	0	0	1	1	/	
	From	Timer start date	Current date +1	Current date +1	12/31/2099	1/1/1	d/m/y	
	Until	Timer end date	Current date +1	Current date +1	12/31/2099	1/1/1	d/m/y	
	Zone 1 holiday timer -timer1-timer6	Enablement 0=inactive, 1=active	0	0	1	1	/	
	Zone 1 holiday timer -timer1-timer6 Time	Timer start time	00:00	00:00	23:50	1/10	h/min	
	Zone 1 holiday timer -timer1-timer6 Mode	Operation mode of the timer 2=Cooling, 1=Heating, 0=OFF	0	0	2	1	/	
	Zone 1 holiday timer -timer1-timer6 Temp.	Set temperature of the timer	For FCU cooling	12	5	25	1	°C
			For FLH / RAD cooling	23	18	25	1	°C
			For FLH heating	30	25	55	1	°C
			For FCU / RAD heating	40	35	85	1	°C
			Room heating set temperature Ta	24	17	30	0.5	°C
	Room cooling set temperature Ta	24	17	30	0.5	°C		
	Zone 2 holiday timer -timer1-timer6	Enablement 0=inactive, 1=active	0	0	1	1	/	
	Zone 2 holiday timer -timer1-timer6 Time	Timer start time	00:00	00:00	23:50	1/10	h/min	
	Zone 2 holiday timer -timer1-timer6 Mode	Operation mode of the timer 2=Cooling, 1=Heating, 0=OFF	0	0	2	1	/	

	Zone 2 holiday timer -timer1-timer6 Temp.	Set temperature of the timer	For FCU cooling	12	5	25	1	°C
			For FLH / RAD cooling	23	18	25	1	°C
			For FLH heating	30	25	55	1	°C
			For FCU / RAD heating	40	35	85	1	°C
			Room heating set temperature Ta	24	17	30	0.5	°C
			Room cooling set temperature Ta	24	17	30	0.5	°C
DHW holiday timer -timer1-timer6	Enablement 0=inactive, 1=active		0	0	1	1	/	
DHW holiday timer -timer1-timer6 Time	Timer start time		00:00	00:00	23:50	1/10	h/min	
DHW holiday timer -timer1-timer6 Mode	Operation mode of the timer 2=Cooling, 1=Heating, 0=OFF		0	0	1	1	/	
DHW holiday timer -timer1-timer6 Temp.	Set temperature of the timer		50	20	75	1	/	
6.3 Weather temp. settings								
Zone heating mode	Temperature curve	Enablement 0=inactive, 1=active	0	0	1	1	/	
	Temperature curve type	Temperature curve type 0=Standard, 1=Custom, 2=ECO	0	0	2	1	/	
	Standard - Temperature level	Curve for FCU / RAD heating	6	1	8	1	/	
		Curve for FLH heating	3	1	8	1	/	
	Standard - Temperature offset	Zone 1 heating set temperature offset of curve	0	-10	25	1	°C	
	Custom - Temperature setting - T1SetH1	Heating set temperature 1 of curve	35	25	85	1	°C	
	Custom - Temperature setting - T1SetH2	Heating set temperature 2 of curve	28	25	85	1	°C	
	Custom - Temperature setting - T4H1	Heating ambient temperature 1 of curve	-5	-25	35	1	°C	
	Custom - Temperature setting - T4H2	Heating ambient temperature 2 of curve	7	-25	35	1	°C	
	ECO - Temperature level	Curve for FLH heating	3	1	8	1	/	
		Curve for FCU / RAD heating	6	1	8	1	/	
	ECO timer	Enablement 0=inactive, 1=active	0	0	1	1	/	
	From	Timer start date	8:00	00:00	23:50	1/10	h/min	
	Until	Timer end date	19:00	00:00	23:50	1/10	h/min	
Zone 1 cooling mode	Temperature curve	Enablement 0=inactive, 1=active	0	0	1	1	/	
	Temperature curve type	Temperature curve type 0=Standard, 1=Custom	0	0	1	1	/	
	Standard - Temperature level	Curve for FLH / RAD cooling	4	1	8	1	/	
		Curve for FCU cooling	4	1	8	1	/	
	Standard - Temperature offset	Zone 1 cooling set temperature offset of curve	0	-10	10	1	°C	
	Custom - Temperature setting - T1SetC1	Cooling set temperature 1 of curve	10	5	25	1	°C	
	Custom - Temperature setting - T1SetC2	Cooling set temperature 2 of curve	16	5	25	1	°C	
	Custom - Temperature setting - T4C1	Cooling ambient temperature 1 of curve	35	-5	48	1	°C	
Custom - Temperature setting - T4C2	Cooling ambient temperature 2 of curve	25	-5	48	1	°C		
Zone 2 heating mode	Temperature curve	Enablement 0=inactive, 1=active	0	0	1	1	/	
	Temperature curve type	Temperature curve type 0=Standard, 1=Custom	0	0	1	1	/	
	Standard - Temperature level	Curve for FCU / RAD heating	6	1	8	1	/	
		Curve for FLH heating	3	1	8	1	/	
	Standard - Temperature offset	Zone 2 heating set temperature offset of curve	0	-10	25	1	°C	
	Custom - Temperature setting - T1SetH1	Heating set temperature 1 of curve	35	25	85	1	°C	
	Custom - Temperature setting - T1SetH2	Heating set temperature 2 of curve	28	25	85	1	°C	
	Custom - Temperature setting - T4H1	Heating ambient temperature 1 of curve	-5	-25	35	1	°C	
	Custom - Temperature setting - T4H2	Heating ambient temperature 2 of curve	7	-25	35	1	°C	

Zone2 cooling mode	Temperature curve	Enablement 0=inactive, 1=active	0	0	1	1	/
	Temperature curve type	Temperature curve type 0=Standard, 1=Custom	0	0	1	1	/
	Standard - Temperature level	Curve for FLH / RAD cooling	4	1	8	1	/
	Standard - Temperature level	Curve for FCU cooling	4	1	8	1	/
	Standard - Temperature offset	Zone 2 cooling set temperature offset of curve	0	-10	10	1	°C
	Custom - Temperature setting - T1SetC1	Cooling set temperature 1 of curve	10	5	25	1	°C
	Custom - Temperature setting - T1SetC2	Cooling set temperature 2 of curve	16	5	25	1	°C
	Custom - Temperature setting - T4C1	Cooling ambient temperature 1 of curve	35	-5	48	1	°C
Custom - Temperature setting - T4C2	Cooling ambient temperature 2 of curve	25	-5	48	1	°C	
6.4 DHW settings							
Disinfect	Current state	State OFF=0, ON=1	1	0	1	1	/
	Operation day Sunday / Monday / Tuesday / Wednesday / Thursday / Friday / Saturday	Enablement 0=inactive, 1=active (if all the date is active, then display 'Every day')	Thursday = 1, other=0	0	1	1	/
	Start	Start time	23:00	00:00	23:50	1/10	h/min
Fast DHW	Fast DHW	State OFF=0, ON=1	0	0	1	1	/
Tank heater	Tank heater	State OFF=0, ON=1	0	0	1	1	/
DHW pump	DHW pump timer 1-12	State OFF=0, ON=1	0	0	1	1	/
	DHW pump timer 1-12 time	Start time	00:00	00:00	23:50	1/10	h/min
6.5 Settings							
Silent mode	Silent mode	Enablement OFF=0, ON=1	0	0	1	1	/
	Silent mode level	0=Silent 1=Super silent	0	0	1	1	/
	Silent mode timer 1	Enablement 0=inactive, 1=active	0	0	1	1	/
	From	Start time 1	12:00	00:00	23:50	1/10	h/min
	Until	End time 1	15:00	00:00	23:50	1/10	h/min
	Silent mode timer 2	Enablement 0=inactive, 1=active	0	0	1	1	/
	From	Start time 2	22:00	00:00	23:50	1/10	h/min
Until	End time 2	07:00	00:00	23:50	1/10	h/min	
Backup heater	Backup heater	Enablement 0=OFF, 1=ON	0	0	1	1	/
Display setting	Time	Current time	00:00	00:00	23:59	1/1	h/min
	Date	Current date	1/1/2023	1/1/2023	12/31/2099	1	/
	Language	0=English, 1=Français, 2=Italiano, 3=Español, 4=Polski, 5=Português, 6=Deutsch, 7=Nederlands, 8=Română, 9=Русский, 10=Türkçe, 11=Ελληνικά, 12=Slovenščina, 13=Svenska, 14=Čeština, 15=Slovák, 16=Magyar, 17=Hrvatski	0	0	17	1	/
	Backlight	Backlight level	2	1	3	1	/
	Buzzer	Enablement, 0 = inactive, 1 = active	1	0	1	1	/
	Screen lock time	lock timer	0	0	300	30	Second
Force defrost	Force defrost	Enablement 0=OFF, 1=ON	0	0	1	1	/

Annex 3. Terms and abbreviation

Tp	Compressor discharge temperature
Th	Compressor Suction temperature
T4	Outdoor air temperature
T3	Heat exchanger temperature
TL	Heat exchanger outlet refrigerant(cooling) temperature
T2	Plate heat exchanger inlet refrigerant(cooling) temperature
T2B	Plate heat exchanger outlet refrigerant(cooling) temperature
Tw_in	Inlet water temperature
Tw_out	Outlet water temperature
T5	DHW tank temperature
Tw2	Zone 2 water temperature
Tbt	Balance tank temperature
T1	IBH/AHS outlet water temperature
Ta	Indoor ambient temperature
SV	3-way valves
Pump_I	Integrated circulation pump
P_c (Pump_C)	Zone 2 pump
P_o (Pump_O)	Additional circulation pump(for Zone 1)
P_s (Pump_S)	Solar heating loop circulation pump
P_d (Pump_D)	DHW pipe pump
AHS	Additional heat source
IBH	Internal backup heater
TBH	Tank booster heater
SG	SG-ready signal 1
EVU	SG-ready signal 2
HMI	Human-machine interface (wired controller)

16125300004119 V.D



Kaysun
by **frigicoll**

MAIN OFFICE

Blasco de Garay, 4-6
08960 Sant Just Desvern
(Barcelona)

Tel. +34 93 480 33 22

<http://www.frigicoll.es/>

<http://www.kaysun.es/en/>

MADRID

Senda Galiana, 1
Polígono Industrial Coslada
Coslada (Madrid)

Tel. +34 91 669 97 01

Fax. +34 91 674 21 00

madrid@frigicoll.es