

ORIGINAL
MANUAL

frigicoll

INSTALLATION & OWNER'S MANUAL

Heat Recovery Ventilator (HRV)

HRV-D500(C) (KRE D500D2)
HRV-D800(C) (KRE D800D2)
HRV-D1000(C) (KRE D1000D2)
HRV-D1500(C) (KRE D1500D2)
HRV-D2000(C) (KRE D2000D2)



Read this manual carefully before using the product, and keep it for future reference.

All the pictures in this manual are for illustration purpose only.

Contents

About The Documentation	1
About This Document / 1	Safety Instructions / 2
Safety Warning	3
Safety Precautions / 3	Electric Safety Requirements / 4
About The Refrigerant / 5	
Operation	8
Operation Precautions / 8	
Installation	10
Installation Precautions / 10	Installation Materials / 18
Indoor Unit Installation / 18	Electrical Connection / 22
Error Codes / 36	Test Run / 39
Maintenance and Service	41
Safety Warning / 41	Cleaning / 41
Service / 42	
Attached Page	43
ErP Information / 43	

About The Documentation

1 About This Document

Note

Make sure that the user has the printed documentation and ask him/her to keep it for future reference.

Target audience

Authorised installers + end users

Note

This appliance is intended to be used by expert or trained users in shops, in light industry, and on farms, or for commercial and household use by lay persons.

Warning

Please thoroughly read and ensure that you fully understand the safety precautions (including the signs and symbols) in this manual, and follow relevant instructions during use to prevent damage to health or property.

Documentation set

This document is part of a documentation set. The complete set consists of:

- General safety precautions:
 - Safety instructions that you must read before installing
- Indoor unit installation and operation manual:
 - Installation and operation instructions
- Controller installation and operation manual:
 - Installation and operation instructions

Please refer to the product manual for other accessories.

Technical engineering data

Latest revisions of the supplied documentation may be available via your dealer.

The original documentation is written in English. All other languages are translations.

2 Safety Instructions

Please thoroughly read and ensure that you fully understand the safety precautions (including the signs and symbols) in this manual, and follow relevant instructions during use to prevent damage to health or property.

Safety Signs



Danger

Indicates a hazard with a high level of risk which, if not avoided, will result in serious injury.



Warning

Indicates a hazard with a medium level of risk which, if not avoided, could result in serious injury.



Caution

Indicates a hazard with a low level of risk which, if not avoided, could result in minor or moderate injury.



Note

Useful operation and maintenance information.

Safety Warning

Warning contents



Ensure Proper Earthing



Professional Only

Prohibition signs



No Laying Inflammable Thing



No Strong Currents



No Open Flame; Fire, Open Ignition Source and Smoking Prohibited



No Acid or Alkali Materials

1 Safety Precautions

Danger

In the event of refrigerant leakage, smoking and open flames are prohibited. Disconnect the main power switch immediately, open windows to allow ventilation, keep away from the leakage point, and contact your local dealer or technical support to request a professional repair.

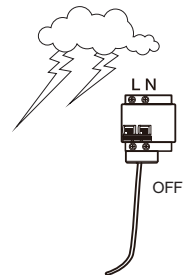

Warning

HRV installation must comply with local standards and electrical codes, and relevant instructions in this manual.

Do not use any liquid cleanser, liquefied cleanser, or corrosive cleanser to wipe this unit or spray water or other liquids on the unit. Otherwise, the plastic parts of the unit will become damaged and an electrical shock may occur. Disconnect the main power switch before cleaning and maintenance to avoid accidents.

Ask a professional to remove and reinstall the HRV.

Ask a professional for maintenance and repair assistance.

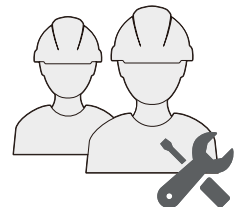

Caution

This appliance can be used by children aged from 8 years and above and persons with reduced physical, sensory or mental capabilities or lack of experience and knowledge if they have been given supervision or instruction concerning use of the appliance in a safe way and understand the hazards involved.

Children shall not play with the appliance.

Cleaning and user maintenance shall not be made by children without supervision.

This appliance is intended to be used by expert or trained users in shops, in light industry and on farms, or for commercial use by lay persons.

When the product is used for commercial application. This appliance is intended to be used by expert or trained users in shops, in light industry and on farms, or for commercial use by lay persons.

2 Electric Safety Requirements

Warning

The HRV shall be installed according to the local wiring specifications.

Wiring work must be completed by qualified electricians.

The HRV must be well earthed. Specifically, the main switch of the HRV must have a reliable earthing cable.

Before contacting wiring devices, cut off all the power supplies.

The user **MAY NOT** disassemble or repair the HRV. Doing so can be dangerous. In the event of a fault, immediately cut off the power and contact your local dealer or technical support.

A separate power supply that meets the rated parameter values must be provided for the HRV.

The fixed wiring to which the HRV is connected must be equipped with a power cut-off device that meets the wiring requirements.

The HRV's circuit board (PCB) is designed with a fuse to provide overcurrent protection. The specifications of the fuse are printed on the circuit board.

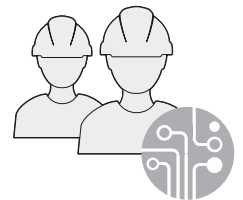
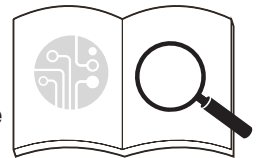

Caution

Under no circumstances should the earth wires of the power supply system be disconnected.

Do not use a damaged power supply cable and replace it if it is damaged.



3 About The Refrigerant

Warning

No person carrying out work in relation to a refrigeration system which involves exposing any pipe work that contains or has contained flammable refrigerant shall use any sources of ignition in such a manner that it may lead to the risk of fire or explosion.

All possible ignition sources, including cigarette smoking, should be kept sufficiently far away from the site of installation, repairing, removing and disposal, during which flammable refrigerant can possibly be released to the surrounding space.

Prior to work taking place, the area around the equipment is to be surveyed to make sure that there are no flammable hazards or ignition risks. “No Smoking” signs shall be displayed.

Ensure that the area is in the open or that it is adequately ventilated before breaking into the system or conducting any hot work. A degree of ventilation shall continue during the period that the work is carried out. The ventilation should safely disperse any released refrigerant and preferably expel it externally into the atmosphere.

Where electrical components are being changed, they shall be fit for the purpose and to the correct specification. At all times the manufacturer’s maintenance and service guidelines shall be followed. If in doubt consult the manufacturer’s technical department for assistance.

The following checks shall be applied to installations using flammable refrigerants:

- the charge size is in accordance with the room size within which the refrigerant containing parts are installed;
- the ventilation machinery and outlets are operating adequately and are not obstructed;
- if an indirect refrigerating circuit is being used, the secondary circuit shall be checked for the presence of refrigerant;
- marking to the equipment continues to be visible and legible. Markings and signs that are illegible shall be corrected;
- refrigeration pipe or components are installed in a position where they are unlikely to be exposed to any substance which may corrode refrigerant containing components, unless the components are constructed of materials which are inherently resistant to being corroded or are suitably protected against being so corroded.

Repair and maintenance to electrical components shall include initial safety checks and component inspection procedures.

If a fault exists that could compromise safety, then no electrical supply shall be connected to the circuit until it is satisfactorily dealt with. If the fault cannot be corrected immediately but it is necessary to continue operation, an adequate temporary solution shall be used. This shall be reported to the owner of the equipment so all parties are advised.

Initial safety checks shall include:

- that capacitors are discharged: this shall be done in a safe manner to avoid possibility of sparking;
- that no live electrical components and wiring are exposed while charging, recovering or purging the system;
- that there is continuity of earth bonding.

During repairs to sealed components, all electrical supplies shall be disconnected from the equipment being worked upon prior to any removal of sealed covers, etc. If it is absolutely necessary to have an electrical supply to equipment during servicing, then a permanently operating form of leak detection shall be located at the most critical point to warn of a potentially hazardous situation.

Particular attention shall be paid to the following to ensure that by working on electrical components, the casing is not altered in such a way that the level of protection is affected. This shall include damage to cables, excessive number of connections, terminals not made to original specification, damage to seals, incorrect fitting of glands, etc.

Ensure that seals or sealing materials have not degraded such that they no longer serve the purpose of preventing the ingress of flammable atmospheres.

Replacement parts shall be in accordance with the manufacturer’s specifications.

Do not apply any permanent inductive or capacitance loads to the circuit without ensuring that this will not exceed the permissible voltage and current permitted for the equipment in use.

Intrinsically safe components are the only types that can be worked on while live in the presence of a flammable atmosphere. The test apparatus shall be at the correct rating.

Replace components only with parts specified by the manufacturer. Other parts may result in the ignition of refrigerant in the atmosphere from a leak.

Check that cabling will not be subject to wear, corrosion, excessive pressure, vibration, sharp edges or any other adverse environmental effects. The check shall also take into account the effects of ageing or continual vibration from sources such as compressors or fans.

When breaking into the refrigerant circuit to make repairs – or for any other purpose – conventional procedures shall be used. However, it is important that best practice is followed.

Since flammability is a consideration. The following procedure shall be adhered to:

- remove refrigerant;
- purge the circuit with inert gas;
- evacuate;
- purge again with inert gas;
- open the circuit by cutting or brazing.

The refrigerant charge shall be recovered into the correct recovery cylinders. The system shall be “flushed” with OFN to render the unit safe. This process may need to be repeated several times. Compressed air or oxygen shall not be used for this task.

Flushing shall be achieved by breaking the vacuum in the system with OFN and continuing to fill until the working pressure is achieved, then venting to atmosphere, and finally pulling down to a vacuum.

This process shall be repeated until no refrigerant is within the system. When the final OFN charge is used, the system shall be vented down to atmospheric pressure to enable work to take place.

This operation is absolutely vital if brazing operations on the pipe-work are to take place.

Ensure that the outlet for the vacuum pump is not close to any ignition sources and there is ventilation available.

Ensure that contamination of different refrigerants does not occur when using charging equipment. Hoses or lines shall be as short as possible to minimise the amount of refrigerant contained in them.

Prior to recharging the system it shall be pressure tested with OFN.

DD.12 Decommissioning:

Before carrying out this procedure, it is essential that the technician is completely familiar with the equipment and all its detail. It is recommended good practice that all refrigerants are recovered safely. Prior to the task being carried out, an oil and refrigerant sample shall be taken in case analysis is required prior to re-use of reclaimed refrigerant. It is essential that electrical power is available before the task is commenced.

- a) Become familiar with the equipment and its operation.
- b) Isolate system electrically.
- c) Before attempting the procedure ensure that:
 - *mechanical handling equipment is available, if required, for handling refrigerant cylinders;*
 - *all personal protective equipment is available and being used correctly;*
 - *the recovery process is supervised at all times by a competent person;*
 - *recovery equipment and cylinders conform to the appropriate standards.*
- d) Pump down refrigerant system, if possible.
- e) If a vacuum is not possible, make a manifold so that refrigerant can be removed from various parts of the system.
- f) Make sure that cylinder is situated on the scales before recovery takes place.
- g) Start the recovery machine and operate in accordance with manufacturer’s instructions.
- h) Do not overfill cylinders. (No more than 80 % volume liquid charge).
- i) Do not exceed the maximum working pressure of the cylinder, even temporarily.
- j) When the cylinders have been filled correctly and the process completed, make sure that the cylinders and the equipment are removed from site promptly and all isolation valves on the equipment are closed off.
- k) Recovered refrigerant shall not be charged into another refrigeration system unless it has been cleaned and checked.

Equipment shall be labelled stating that it has been de-commissioned and emptied of refrigerant. The label shall be dated and signed. Ensure that there are labels on the equipment stating the equipment contains flammable refrigerant.

When removing refrigerant from a system, either for servicing or decommissioning, it is recommended good practice that all refrigerants are removed safely.

When transferring refrigerant into cylinders, ensure that only appropriate refrigerant recovery cylinders are employed. Ensure that the correct number of cylinders for holding the total system charge are available. All cylinders to be used are designated for the recovered refrigerant and labelled for that refrigerant (i.e. special cylinders for the recovery of refrigerant). Cylinders shall be complete with pressure relief valve and associated shut-off valves in good working order. Empty recovery cylinders are evacuated and, if possible, cooled before recovery occurs.

The recovery equipment shall be in good working order with a set of instructions concerning the equipment that is at hand and shall be suitable for the recovery of flammable refrigerants. In addition, a set of calibrated weighing scales shall be available and in good working order. Hoses shall be complete with leak-free disconnect

couplings and in good condition. Before using the recovery machine, check that it is in satisfactory working order, has been properly maintained and that any associated electrical components are sealed to prevent ignition in the event of a refrigerant release. Consult manufacturer if in doubt.

The recovered refrigerant shall be returned to the refrigerant supplier in the correct recovery cylinder, and the relevant Waste Transfer Note arranged. Do not mix refrigerants in recovery units and especially not in cylinders.

If compressors or compressor oils are to be removed, ensure that they have been evacuated to an acceptable level to make certain that flammable refrigerant does not remain within the lubricant. The evacuation process shall be carried out prior to returning the compressor to the suppliers. Only electric heating to the compressor body shall be employed to accelerate this process. When oil is drained from a system, it shall be carried out safely.

Warning: disconnect the appliance from its power source during service and when replacing parts.

These units are partial unit HRV, complying with partial unit requirements of this International Standard, and must only be connected to other units that have been confirmed as complying to corresponding partial unit requirements of this International Standard.

Operation

1 Operation Precautions

Warning

If the unit will be not used for a long time, disconnect the main power switch. Otherwise, an accident may occur.

The installation height of the HRV shall be at least 2.5m above the ground to avoid the following risks:

1. Touching of moving or live parts, such as fans, motors, or louvers, by a non professional. Running parts may cause harm to you or transmission assemblies may become damaged.
2. Getting too close to the HRV may reduce the level of comfort.

Do not let children play with the HRV. Otherwise, an accident may occur.

Do not expose the indoor units or controller to moisture or water as this may cause short circuiting or fire.

Do not place any appliance that uses an open flame in the direct air supply of the HRV as it could interfere with the combustion of the appliance.

Do not use or store flammable gases or liquids such as natural gas, hair spray, paint or gasoline near the HRV. Otherwise, a fire may occur.

To avoid causing harm, do not place animals or plants directly in front of the HRV's air supply.

In the event of abnormal conditions such as abnormal noise, smell, smoke, temperature rise, and electric leakage, please cut off the power immediately, and then contact your local dealer or HRV customer service center. Do not repair the HRV by yourself.

Do not place flammable sprayers near the HRV or spray it directly at the HRV. Otherwise, a fire may occur.

Do not place a container of water on the HRV. If immersed in water, the HRV's electrical insulation will weaken, resulting in electrical shock.

After long-term use, confirm whether the installation platform has become worn. If it is worn, the unit could fall, causing injury.

Do not operate the switch with wet hands, as this may result in electric shock.

When servicing the HRV, be sure to turn off the HRV and cut off the power supply. Otherwise, the high-speed operation of the internal fan will cause injury.

Do not use fuses like iron or copper wire other than those with the specified capacity. Otherwise, a malfunction or fire may occur. The power supply must use the special circuit of the HRV at the rated voltage.

Do not place valuables under the HRV. HRV condensation problems may damage the valuables.

When the HRV needs to be moved and re-installed, please entrust the local dealer or a professional technician to operate it.

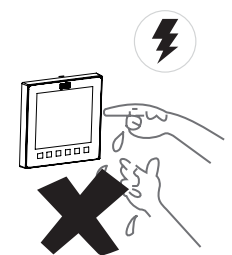
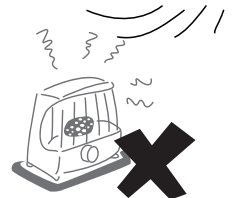

Disposal: Do not dispose of this product as unsorted municipal waste. Collection of such waste separately for special treatment is necessary.

Do not dispose of electrical appliances as unsorted municipal waste, use separate collection facilities.

Contact your local government for information regarding the collection systems available.

If electrical appliances are disposed of in landfills or dumps, hazardous substances can leak into the groundwater and get into the food chain, damaging your health and well-being.



Caution

To use the unit normally, please follow the “Operation” section in this manual.

Lightning or the starting and stopping of large electrical equipment in nearby factories may cause misoperation of the HRV. Please turn off the main power switch for a few seconds, and then restart the HRV.

To avoid accidental resetting of the thermal circuit breaker, the HRV cannot be powered by an external switching device such as a timer or connected to a circuit that is turned on and off by a common component timer.



Installation

Carefully read this manual before installing the indoor unit.

1 Installation Precautions

Qualification And Safety Regulation Requirements

Warning

Please carry out the installation according to local standards.

Ask your local dealer or professionals to install the product.

This unit must be installed by professional technicians with relevant specialized knowledge. Users MAY NOT install the unit themselves; otherwise, faulty operations may cause the risks of fire, electrical shock, injury, or leakage, which could harm you or others or damage the HRV.

Never modify or repair the unit on your own.

Otherwise, a fire, electric shock, injury or water leakage may occur. Get your local dealer or a professional to do so.

Ensure that the residual current device is installed.

The residual current device must be installed. Failure to install it may result in electric shock.

When powering the unit, follow the regulations of the local electric company.

Make sure that the unit is earthed reliably in accordance with laws. If the earthing is not completed correctly, it may cause electrical shock.

When moving, disassembling or reinstalling the HRV, get the assistance of your local dealer or a professional.

If installed improperly, fire, electrical shock, injury, or water leakage may occur.

Use the optional accessories specified by local dealer.

The installation of these accessories must be carried out by professionals. Improper installation may cause fire, electrical shock, water leakage and other hazards.

Use only power supply cable and communication cables that meet specification requirements. Properly connect all the wiring to make sure that no external forces are acting on the terminal blocks, power supply cable and communication cables. Improper wiring or installation may cause a fire.

The HRV must be earthed. Check whether the earth line is securely connected or broken. Do not connect the earth line to gas cans, water piping, lightning rods or telephone earth lines.

The main power switch of the HRV should be put in a position that is out of the reach of children.

It should not be obstructed by flammable objects such as curtains.

Before and after installation, exposing the unit to water or moisture will cause electrical short circuit.

Do not store the unit in a humid basement or expose it to rain or water.

Make sure the installation base and lifting are robust and reliable;

Insecure installation of the base may cause the HRV to fall, leading to an accident. Take into full consideration the effects of strong winds, typhoons and earthquakes, and reinforce the installation.

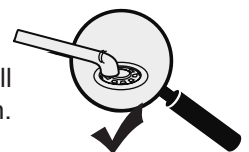
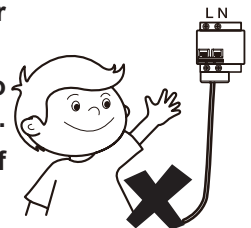
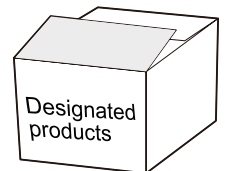
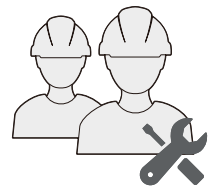

Caution

Keep the indoor unit, outdoor unit, power supply cable, and connecting wires at least 1m away from the high-power radio equipment, to prevent electromagnetic interference and noise. For some electromagnetic waves, it is not enough to prevent noise even at a distance of more than 1m.

For safety, please dispose of the packing materials properly.

Nails and other packaging materials may cause personal injury or other risks. Tear up the plastic packaging bag and dispose of it properly to prevent children from playing with it, leading to suffocation.

Do not cut off the power supply immediately after the indoor unit stops running.

If the length and direction of the air inlet/outlet panel or connecting duct have been changed, complete the following settings on the controller before use the HRV again: (For details, see the Application Control section)

Reset the initial static pressure on the controller or perform a trial run on the outdoor unit (performed by the installer), and set the current state as a reference state for the unit to determine the filter status.

If the above operations are not performed, then the unit may not detect the state of the filter accurately.

This unit is a partial unit HRV, complying with partial unit requirements of this International Standard, and must only be connected to other units that have been confirmed as complying to corresponding partial unit requirements of this International Standard.

The electrical interfaces shall be specified with purpose, voltage, current, and safety class of construction.

The SELV connection points, if provided, are to be clearly indicated in the instructions.

The connection point should be marked with the “read the instructions” symbol per ISO 7000-0790 (2004-01) and the Class III symbol according to IEC 60417-5180 (2003-02).









Precautions For Carrying And Lifting The HRV

- ① Before carrying the HRV, determine the route that will be used to move it to the installation site.
- ② Do not unseal the HRV until it is moved to the installation site.
- ③ When unpacking and moving the HRV, must hold the hanger seat and do not apply force to other parts, so as to avoid damaging the HRV and causing personal injury.

Forbidden Installation Sites

Warning





Do not install or use the HRV in the following places:

-  A place filled with mineral oil, fumes or mist, like a kitchen.
Plastic parts will age and the heat exchanger will become dirty, eventually causing the HRV performance to deteriorate or leak water.
-  A place where there are corrosive gases, such as acid or alkaline gases.
Connecting pipes and copper welds will be corroded, resulting in refrigerant leakage.
-  A place exposed to combustible gases and using volatile combustible gases such as diluent or gasoline.
The electronics in the HRV may cause the surrounding gas to ignite.
-  A place where there is equipment emitting electromagnetic radiation.
The control system will fail and the HRV will not function properly.
-  A place where there is a high salt content in the air like a coastal area.
-  Do not use the HRV in an environment where an explosion may occur.
-  The unit cannot be installed on moving vehicles such as truck and ship.
-  Factories with major voltage fluctuations in the power supplies.
-  Other special environmental conditions.



Recommended Installation Sites

It is recommended to install the HRV according to the design drawing of the HVAC engineer.
The selection principle for the installation site is as follows:

-  Ensure that the airflow in and out of the indoor unit is reasonably organized.
-  Ensure indoor unit maintenance space.
-  Prevent the HRV from blowing directly at the human body.
-  The indoor unit should not be lifted in the places like load-bearing beams and columns that affect the structural safety of the house.
-  The wired controller and the indoor unit should be in the same installation space; otherwise, the sampling point setting of the wired controller needs to be changed.

Choose a site that fully complies with the following conditions and user requirements to install the air conditioning unit:

- There is enough space for installation and maintenance.
- The ceiling is level, and the structure is strong enough to support the indoor unit. If necessary, take measures to reinforce the unit's stability.
- It is easy to supply airflow to every corner of the room.
- There is no direct heat radiation.
- Avoid installation in narrow spaces or where there are more stringent noise requirements.

Main Parts Of The Unit

500-1000m³/h

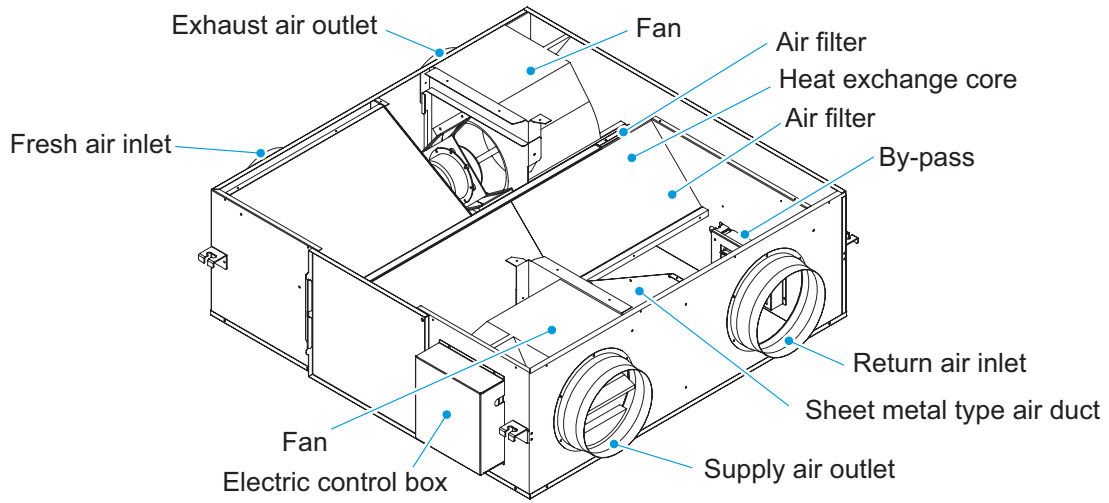

1500-2000m³/h

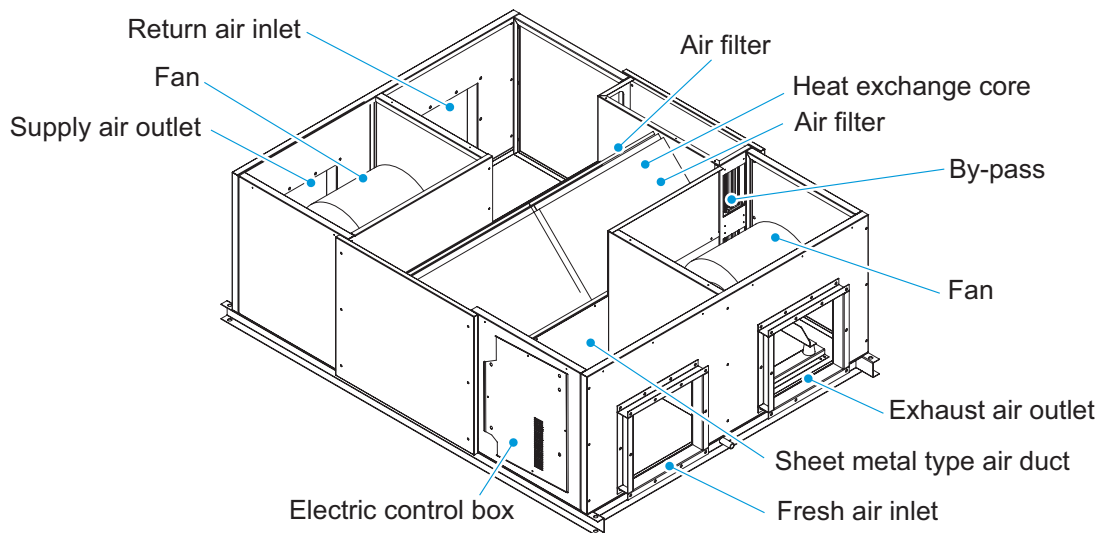

⚡ Note

All the optional accessories should be from local dealer.

For optional accessories such as wired controllers, please refer to the manuals of these accessories.

All the figures in the manual explain only the general appearance and functions of the product. The appearance and functions of the purchased product may not be completely consistent with those listed in the figures. Please refer to the actual product.

Product Dimensions

(Unit: mm)

HRV-D500(C) (KRE D500D2)~HRV-D1000(C) (KRE D100D2)

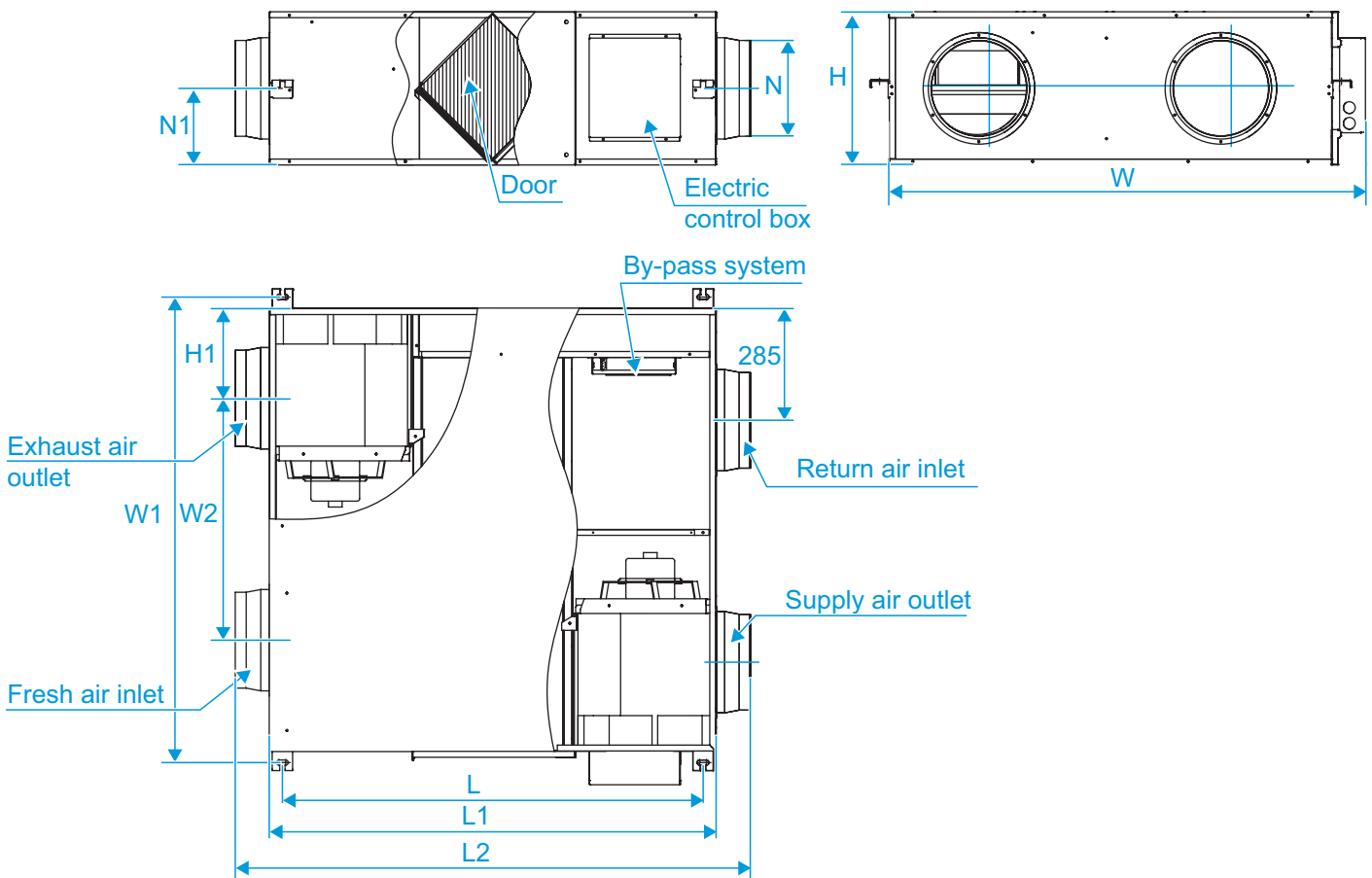

Air volume (m ³ /h)	L	L1	L2	W	W1	W2	H	H1	N	N1
500	1071	1138	1311	1090	1005	465	390	227	Φ244	195
800	1071	1138	1311	1270	1185	616	390	229	Φ244	195
1000	1071	1138	1311	1510	1431	764	390	230	Φ244	195

1500m³/h

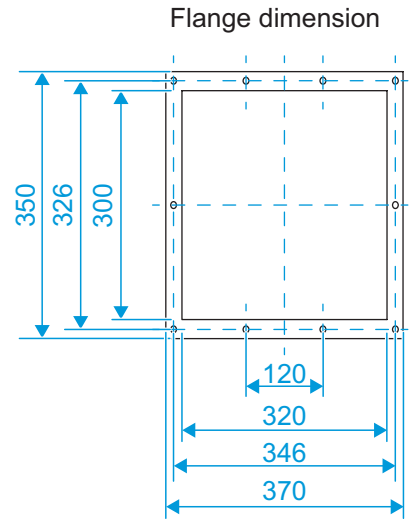
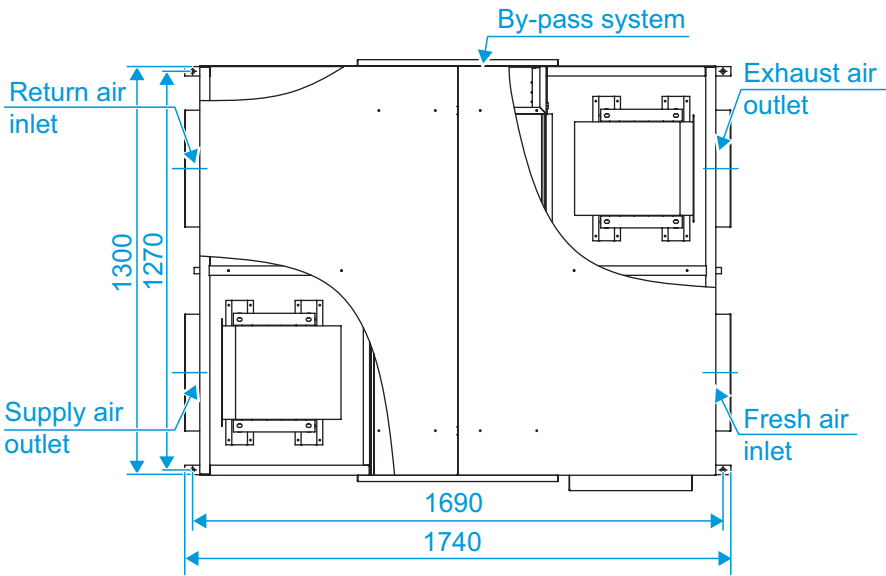
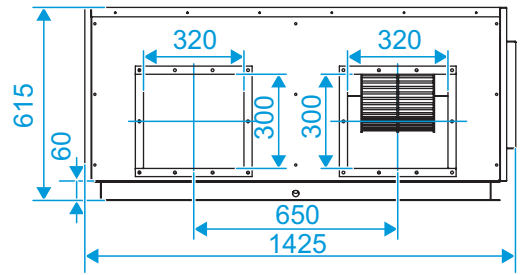
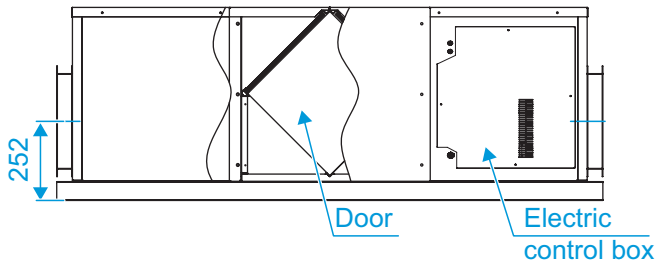

2000m³/h

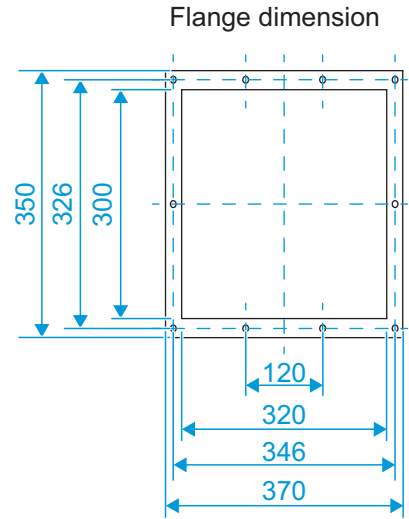
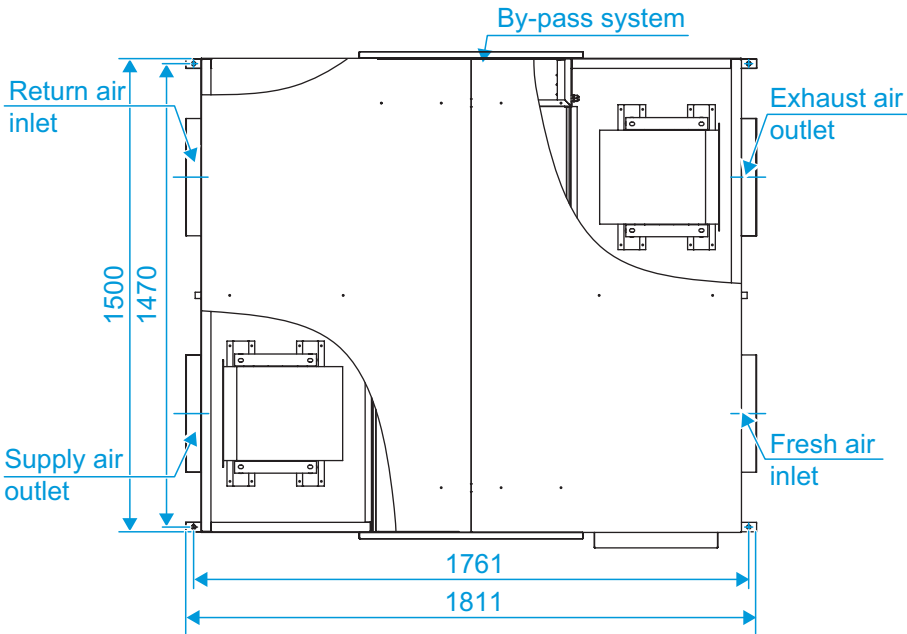
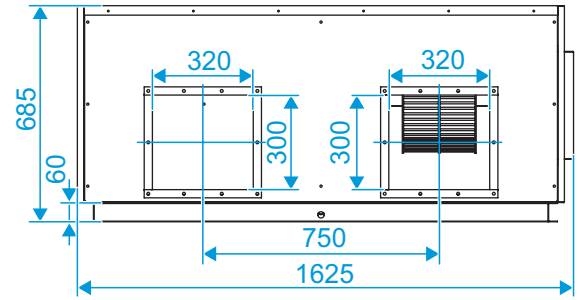
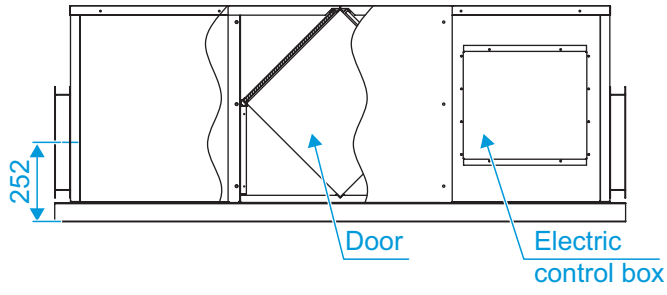

2 Installation Materials

Accessories

List of accessories

Installation and Operation Manual X 1 (Make sure to hand it over to the user)	Cable tie X 2
--	---------------

Note

Check the accessory kit for the above items and contact your local dealer for any missing items.

Do not throw away any accessories that may be required for installation until the installation is complete.

The materials necessary for flexible hose connecting the air outlet and various fasteners (screw, etc.), power supply cable, etc. need to be purchased by the installer on site. The materials and specifications must comply with the corresponding local or industrial standards.

3 Indoor Unit Installation

Installation Preparation

Warning

Keep all the accessories and tools until installation work is completed.

- Leave the unit inside its packaging while moving, until reaching the installation site. Where unpacking is unavoidable, use a sling of soft material or protective plates together with a rope when lifting, to avoid damage or scratches to the unit.
- Hold the unit by the hanger brackets when opening the crate and moving it, and do not lift it holding on to any other part (especially the duct connecting flange).

Note

Be sure to instruct customers how to properly operate the unit (especially maintenance of air filter, and operation procedure) by having them carry out operations themselves while looking at the manual.

Select The Installation Site

Caution

When moving the unit during or after unpacking, make sure to lift it by holding its hanger brackets. Do not exert any pressure on other parts, especially duct connecting flange.

Select an installation site where the following conditions are fulfilled and meet with your customer's approval.

- HRV should be installed far away from office, recreation or any other places where silent environment are required. (install that in special machine room or wash room is recommended)
- Install in a place which has sufficient strength and stability. (Beam, ceiling and other locations capable of fully supporting the weight of the unit.) Insufficient strength is dangerous. It may also cause vibration and unusual operating noise.
- Do not install the unit directly against a ceiling or wall. (If the unit is in contact with the ceiling or wall, it can cause vibration.)
- Where sufficient clearance for maintenance and service can be ensured.

Caution

Install the units, power supply wiring and connecting wires at least 1 meter away from televisions or radios in order to prevent interference or noise. (Depending on the radio waves, a distance of 1 meter may not be sufficient enough to eliminate the electric interference.)

The bellows may not be able to be used in some districts, so exercise caution. contact your local government office or fire department for details.

When discharging exhaust air to a common duct, the Building Standard Law requires the use of fire proof materials, so attach a 2m copper plate standing duct.

Do not install the unit in the following locations:

- Place subjected to high temperature or direct flame. May result in fire or overheating.
- Place such as machinery plant and chemical plant where gas, which contains noxious gas or corrosive components of materials such as acid, alkali organic solvent and plait, is generated. Place where combustible gas leakage is likely.
Copper piping and brazed joins may corrode, causing refrigerant to leak or poisoning and fore due to leaked gas.
- Place such as bathroom subjected to moisture.
Electric leak or electric shocks and other failure can be caused.
- Near machinery emitting electromagnetic waves.
Electromagnetic waves may disturb the operation of the control system and result in a malfunction of the equipment.

Preparations Before Installation

- Confirm the positional relationship between the unit and suspension bolts.
- Leave space for servicing the unit and include inspection hatches. (Always open a hole on the side of the electric parts box so that the air filters, heat exchange elements, fans, be easily be inspected and serviced.)
- Make sure the range of the unit's external static pressure is not exceeded.
- Open the installation hole (Pre-setting ceilings)
- Once the installation hole is opened in the ceiling where the unit is to be installed, pass transmission wiring, and remote controller wiring to the unit's wiring holes.
- After opening the ceiling hole, make sure ceiling is level if needed. It might be necessary to reinforce the ceiling frame to prevent shaking.
- Please consult architect or woodworker, if necessary.
- Install the suspension bolts. (Use M10 to M12 suspension bolts.) Use a hole-in anchor, sunken insert anchor for existing ceilings, or other parts to be procures in the field to reinforce the ceiling to bearing the weight of the unit.
- Install vibration damping feet. (For vibration damping)

Installation Of Lifting Bolts

Refer to the following figure on installation using the lifting bolts.

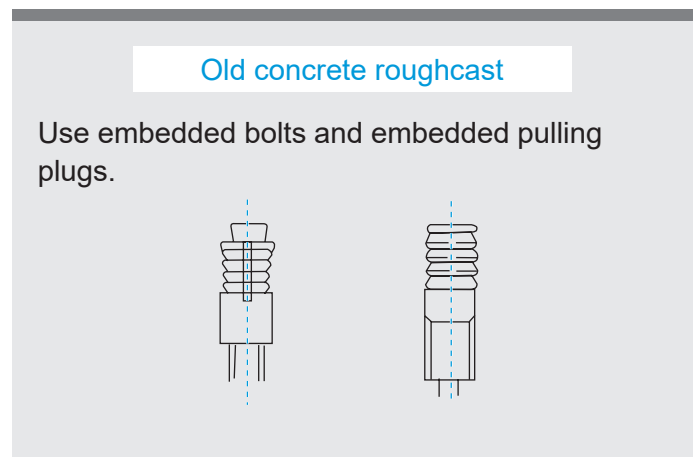
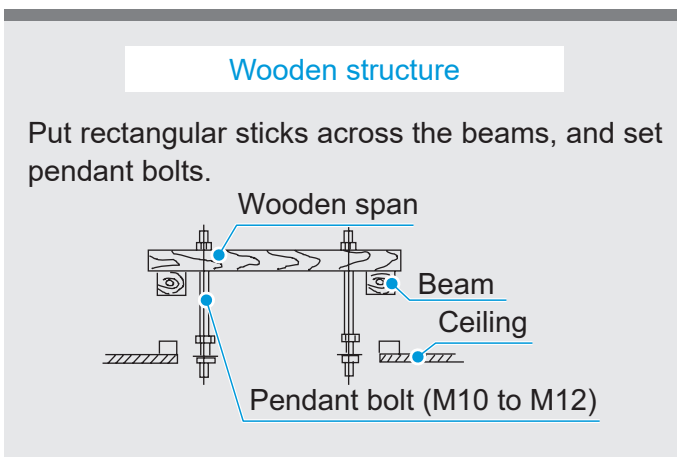

Steel beam and girder structure

Directly set and use an angle iron for support.

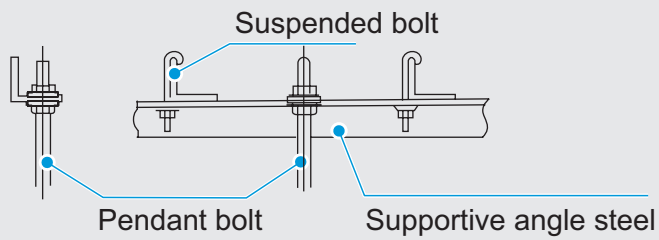

New concrete roughcast

Set it with embedded bushes or embedded bolts.

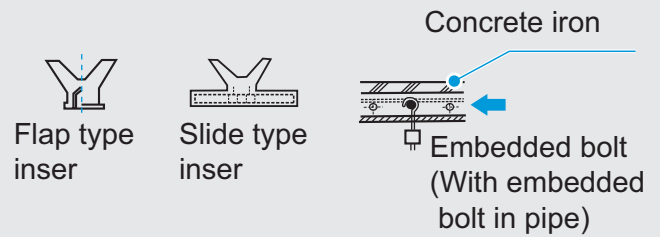

Installation

- Before installation, please confirm all external parts are stand in their place and without damage.
- The surrounding environment of the unit, especially the sides of wiring cabinet and water collecting side should reserve sufficient wiring and maintenance and space; additionally, one should ensure the removing space for filter griller.
- Unit should mount steadily and without sustain the weight form condensate water pipe and air duct. The vents of air inlet/outlet and return should be connected with flexible tube.
- Unit in AC 220-240V/50Hz, reliable grounding; each one possesses of independent cut-off and protection device.
- The installation dimension and maintenance space. (See the following attached picture)
- Operating conditions.

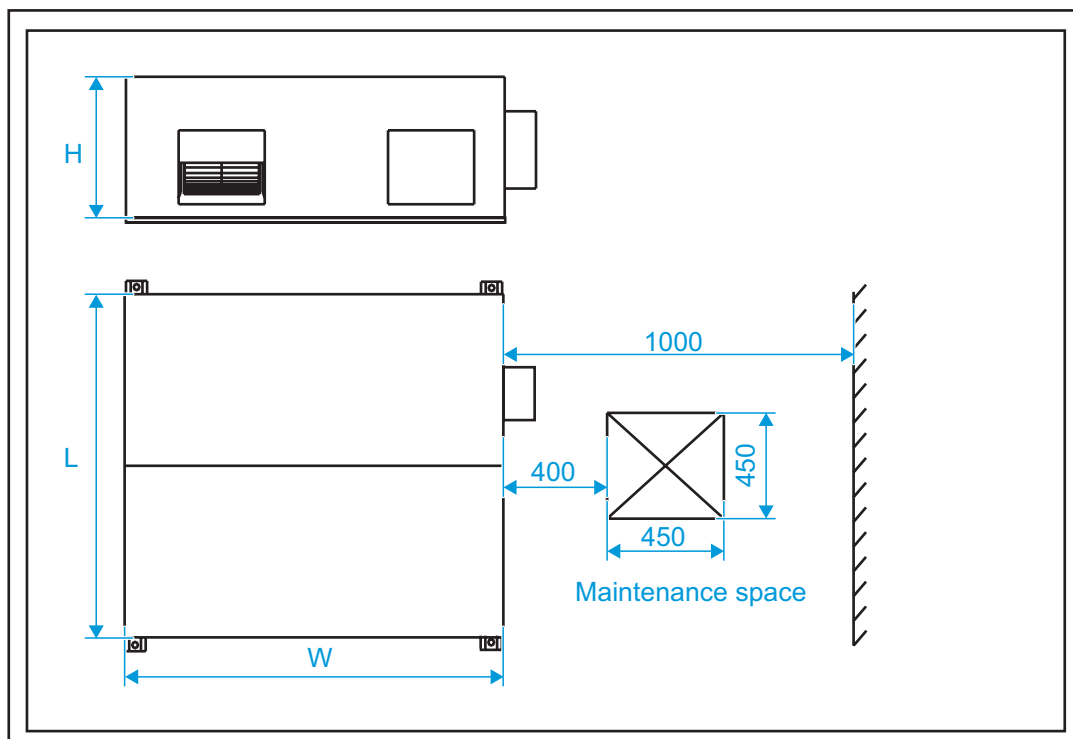

multiple indoor units

For proper performance, run the HRV under the following temperature conditions:

OPERATION	Outdoor air TEMP.	-7°C~43°C
	Room TEMP.	0°C~43°C
	Room humidity	Lower than 80% If higher than 80%, the surface of indoor unit may be condensed or the condensate will be blown from air outlet.

Protection or error may occur if running the unit beyond the above condition, and will cause unit stop running.

4 Electrical Connection

Danger

The power supply must be cut off before any electrical work is carried out. Do not conduct electrical work when the power is on; otherwise, it may cause serious personal injury.

The air conditioning unit must be earthed reliably and must meet the requirements of the local country/region. If the earthing is not reliable, serious personal injury due to electric leakage may occur.

Warning

Installation, inspection or maintenance operations must be completed by professional technicians. All parts and materials must comply with the relevant regulations of the local country/region.

The air conditioning unit must be equipped with a special power supply, and the power supply voltage should conform to the nominal working voltage range of the air conditioning unit.

The power supply of the air conditioning unit must be equipped with a power disconnect device that conforms to the requirements of relevant local technical standards for electrical equipment. The power disconnecting device must be equipped with short circuit protection, overload protection and electric leakage protection. The clearance between open contacts of the power disconnecting device shall be at least 3mm.

The core of the power supply cable must be made of copper, and the wire diameter should meet the current-carrying requirements. For details, refer to the "Power supply cable Diameter and Electric Leakage Protector Selection". A wire diameter that is too small may cause the power supply cable to heat up, resulting in a fire.

The power supply cable and the earth wires should be secured reliably to avoid stress on the terminals. Do not pull the power supply cable forcibly; otherwise, the wiring may become loosened or the terminal blocks may be damaged.

Strong current wires such as power supply cable cannot be connected to weak current wires such as communication wiring; otherwise, the product may be seriously damaged.

Do not bond and connect the power supply cable. Bonding and connecting the power supply cable may cause it to heat up, resulting in a fire.

Caution

Avoid bonding and connecting the communication wiring. If doing so is unavoidable, at the very least, ensure a reliable connection by crimping or soldering and make sure the copper wire at the connection is not exposed; otherwise, communication failure may occur.

The power supply cable and communication wiring must be routed separately, with a distance of over 5 cm. Otherwise, communication failure may occur.

Keep the vicinity of the air conditioning unit as clean as possible to avoid small animals from nesting and biting the cables. If a small animal touches or bites the cables, short circuiting or electric leakage may occur.

Do not connect the earth wires to the gas pipe, water pipe, lightning rod earth wires or telephone earth wires.

Gas pipe: Risk of explosion and fire when gas leaks.

Water pipe: If rigid plastic pipes are used, there will be no earthing effect.

Lightning rod earth wires or telephone earth wires: In the event of lightning strikes, abnormal earth potential may rise.

After all wiring is completed, check carefully before turning on the power supply.

Electrical Characteristics

Air volume (m ³ /h)	Electric specifications of the indoor unit			
	Frequency (Hz)	Voltage (V)	Rated power output (W)	FLA (A)
500	50	220-240	170	1.2
800			170	2.4
1000			170	2.9
1500			750	3.8
2000			750	5.7

Notes:

FLA: Full Load Amps. (A), which is the full load current of the indoor fan motor (reliable operation at the fastest speed setting).

Schematic Figure Of The Main Terminal Blocks Of Main Control Board

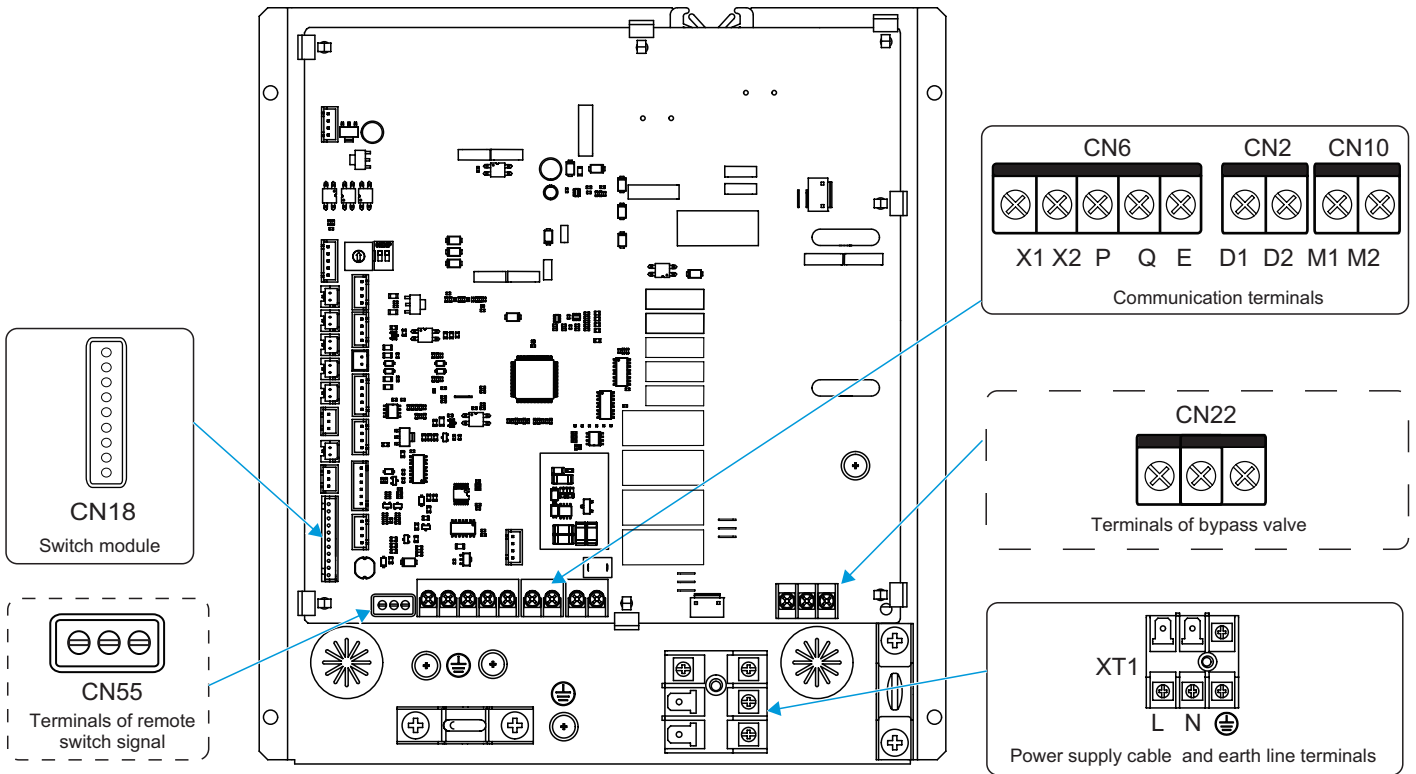

Available for 200-1000 m³/h models

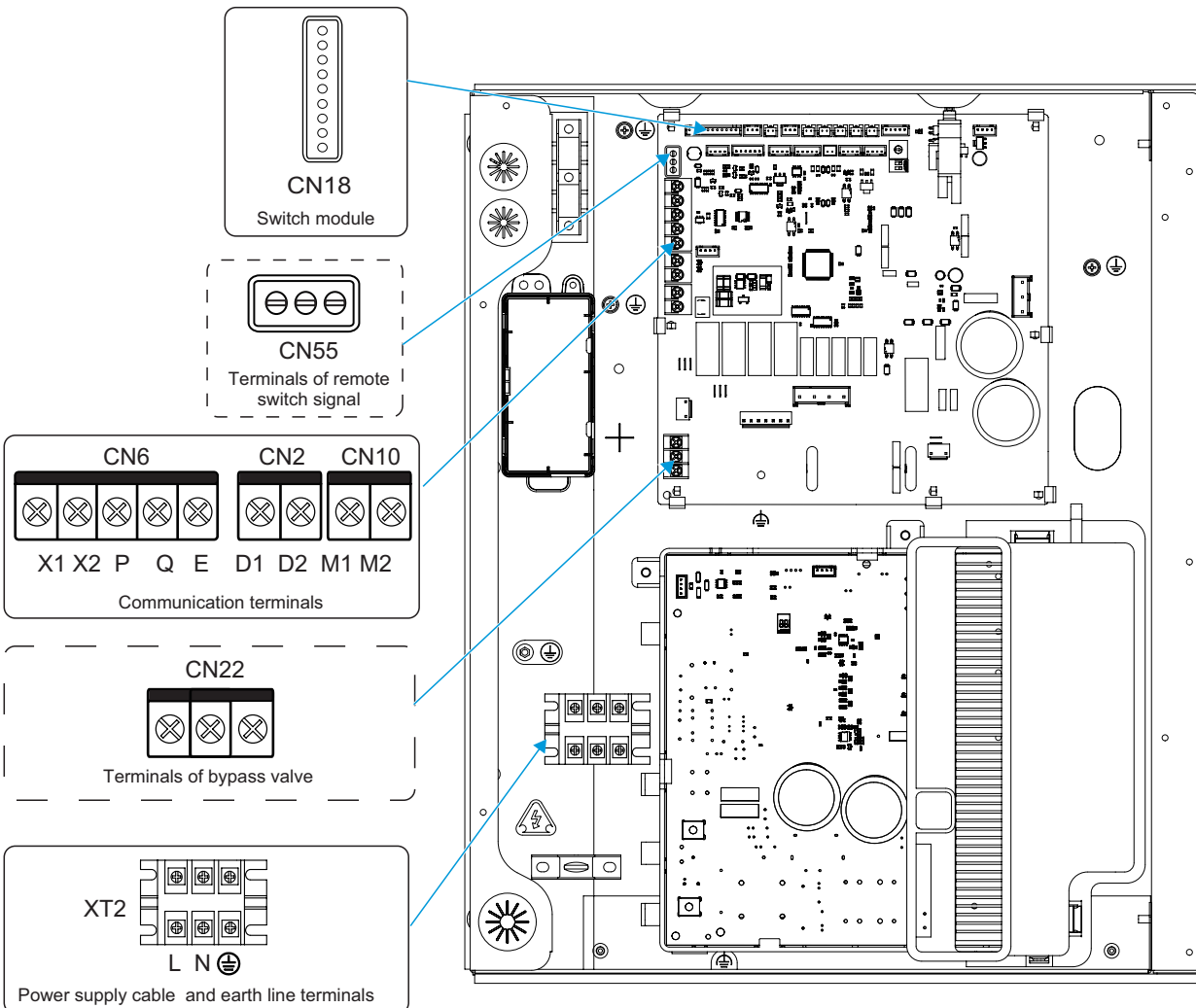

Available for 1500-2000 m³/h models

Caution



All weak point connection points meet SELV, such as X1, X2, P, Q, E, M1, M2, CN18, CN55 etc.

Wiring

- 1 Open the indoor unit's electric control box cover.
 - ① Remove the screws at the positions shown in the figure;
 - ② Pull the bottom end of the electric control box cover horizontally outward;
 - ③ Remove the electric control box cover by pulling downwards.

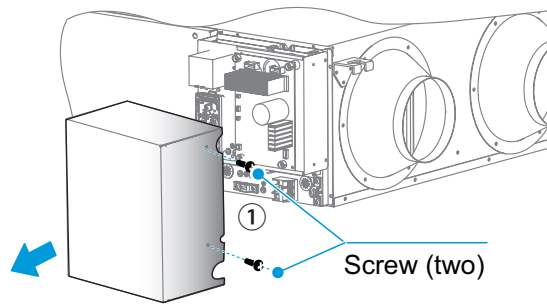

Available for 200-1000 m³/h models

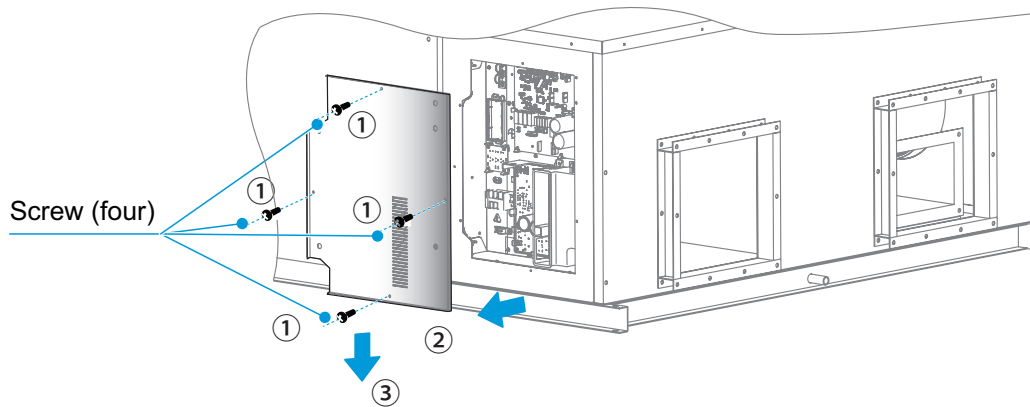

Available for 1500-2000 m³/h models

- 2** Connect the strong current wires (power supply cable) and weak current wires (communication wiring, remote switch commucation wiring, expansion board commucation wiring) to the electric control box through the strong and weak current inlets of electric control box.

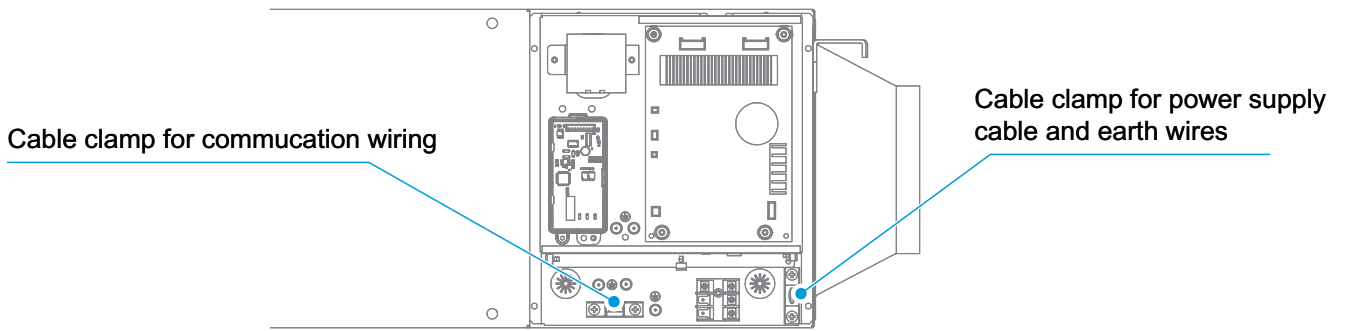

Available for 200-1000 m³/h models

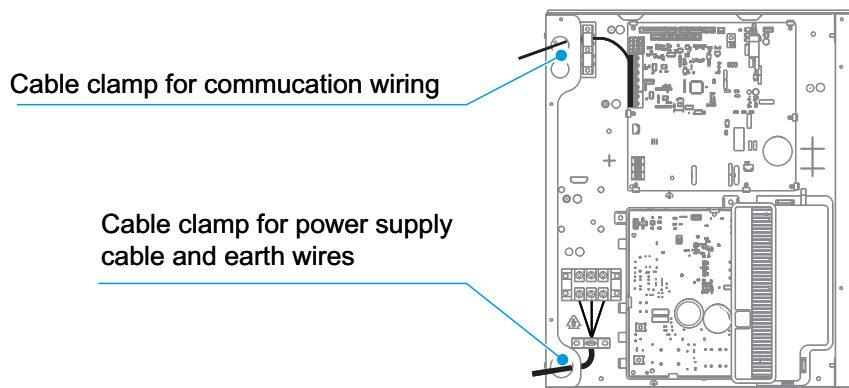

Available for 1500-2000 m³/h models

⚠ Caution

- The strong and weak current wires must be separated.
- The expansion board are optional.

3 Power supply cable connection

- ① Connection between the power supply cable and power supply terminal

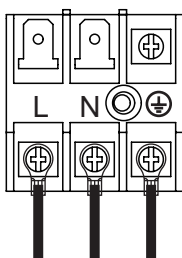

Available for 200-1000 m³/h models

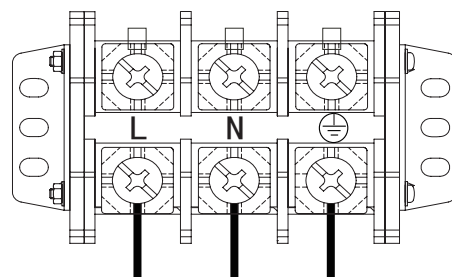

Available for 1500-2000 m³/h models

Power supply	Phase	Single phase
	Voltage /frequency	220-240V/50Hz
Input current Main switch /fuse(A)		15/30
Power supply wire Dimension	Wire's qty	3 (Earthing line should be used yellow/green wire.)
	Wire crossection (mm ²)	2.5

⚠ Caution

A Do not bond and connect the power supply cable. Bonding and connecting the power supply cable may cause it to heat up, resulting in a fire.

B The power supply cable must be crimped reliably using an insulated circular terminal block, and then connected to the power supply terminal of the indoor unit, as shown in the figure below.

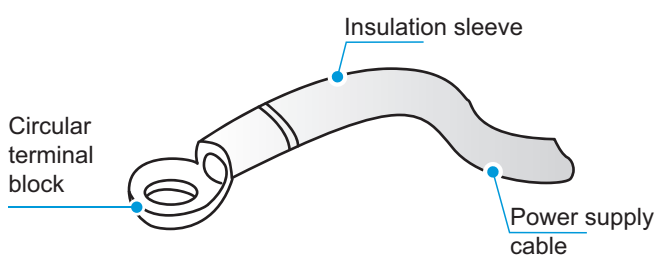

C If it fails to crimp the insulated circular terminal block due to on-site limitations, connect the power supply cable of the same diameter to both sides of the power supply terminal block of the indoor unit, as shown in the figure below.

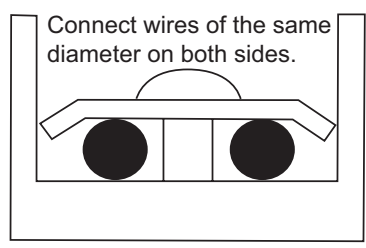

D Do not press the power supply cable of the same wire diameter on the same side of the terminal. Do not use two power supply cable of different wire diameters for the same terminal blocks; otherwise, they can easily loosen due to uneven pressure and cause accidents, as shown in the figure below.

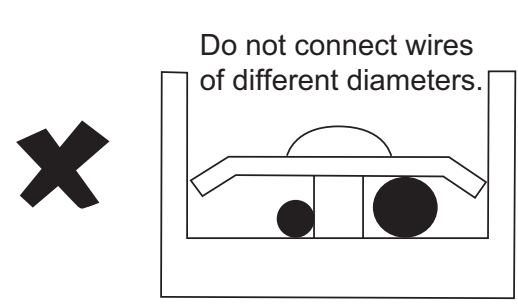
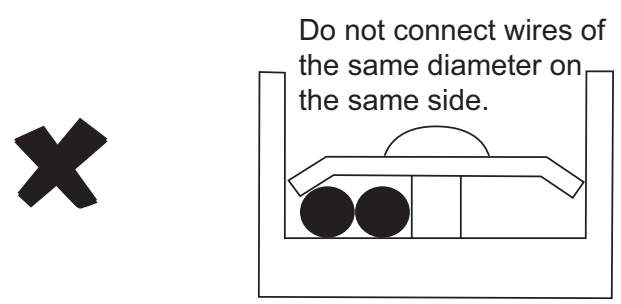

E The connected power supply cable should be secured with a wire clamp to prevent loosening, as shown in the right figure.

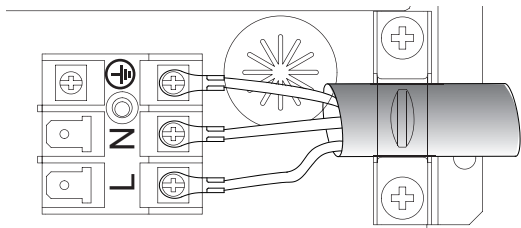

Available for 500-1000 m³/h models

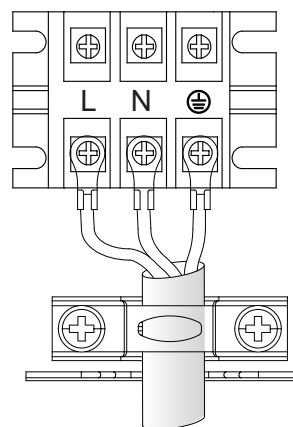

Available for 1500-2000 m³/h models

4 Communication wiring connection

① Selection of communication method for indoor units

Equipped with independently developed HyperLink (M1M2) communication, V8 series indoor units also preserve the previous RS-485 (PQE) communication method. They are compatible with non-V8 indoor units. Pay attention to the type of indoor unit before connecting communication wiring. Please refer to the following table to select an appropriate communication method.

Indoor unit type	Optional communication method between indoor units and outdoor unit	Remarks
Are all the indoor units in the system V8 series	HyperLink (M1M2) communication	<ol style="list-style-type: none"> Any topology connection of communication wiring. Two-core and non-polar communication for M1M2.
	RS-485 (PQ) communication	<ol style="list-style-type: none"> The communication cables must be connected in serial. Two-core and non-polar communication for PQ.
Are some of the indoor units in the system non-V8 series	RS-485 (PQE) communication	<ol style="list-style-type: none"> The communication cables must be connected in serial. PQE cables must be 3-core and PQ non-polar.

② Table of selection of communication wiring diameter

Function	Indoor unit and outdoor unit communication			One controller to one indoor unit (Two controllers to one indoor unit) Communication	One-to-more (centralized controller) Communication
	HyperLink (M1M2) communication	P/Q communication	P/Q/E communication	X1X2 communication	D1D2 communication
Wire diameter	2 × 0.75mm ²	2 × 0.75mm ² (shielded cable)	3 × 0.75mm ² (shielded cable)	2 × 0.75mm ² (shielded cable)	2 × 0.75mm ² (shielded cable)
Length	≤ 2000m	≤ 1200m	≤ 1200m	≤ 200m	≤ 1200m

 **Caution**

Please select the communication wiring according to the requirements in the above reference table. Use shielded cables for communication when strong magnetism or interference is present.

On-site wiring must comply with the relevant regulations of the local country/region and must be completed by professionals.

Do not connect the communication wiring when the power is on.

Do not connect the power supply cable to the communication terminal; otherwise, the main control board may be damaged.

The standard value of the screw torque of the communication wiring terminal is 0.5N·m. Insufficient torque may cause poor contact; excessive torque may damage the screws and power supply terminals.

Both HyperLink (M1M2) communication and PQ communication are internal and external, so only one of the two can be selected. Do not connect both HyperLink (M1M2) communication wiring and PQ communication wiring to the same system, otherwise the indoor unit and outdoor unit cannot communicate normally.

If some of the indoor units in the same refrigerant system are non-V8 series, only P/Q/E communication can be selected for the indoor unit and outdoor unit communication. The three-core shielded cable of 3×0.75mm² is required to connect “P”, “Q”, and “E”.

Do not bundle the communication wiring with the refrigerant pipeline, power supply cable, etc. When the power supply cable and the communication wiring are laid in parallel, a distance of more than 5cm should be maintained to prevent interference from the signal source.

When the construction personnel of the indoor unit and outdoor unit are working separately, information communication and synchronization are required. Do not connect the outdoor unit to HyperLink (M1M2) and the indoor unit to PQ. Do not connect the outdoor unit to PQ and the indoor unit to HyperLink (M1M2).

Bonding and connecting the communication wiring should be avoided, but if it is used, at the very least, ensure a reliable connection by crimping or soldering and make sure the copper wire at the connection is not exposed; otherwise, communication failure may occur.

③ Indoor unit and outdoor unit communication

A HyperLink (M1M2) communication

Single unit: HyperLink (M1M2) communication is a new type of indoor unit and outdoor unit communication technology. M1 and M2 ports are located at terminal block “CN10” of the main control board. There is no distinction between negative and positive electrodes. For details, see the following figure:

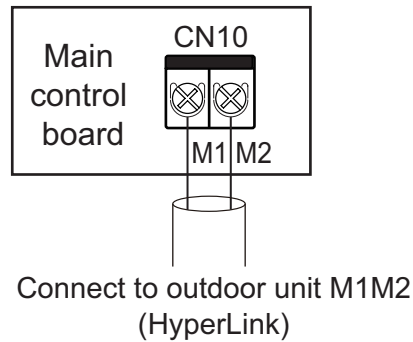

⚠ Caution

Do not connect the HyperLink (M1M2) communication wiring to the PQ or D1D2 communication wiring.

System: The HyperLink (M1M2) communication wiring can reach a length of up to 2000 meters, supporting any topology connection. The following figure shows a serial connection:

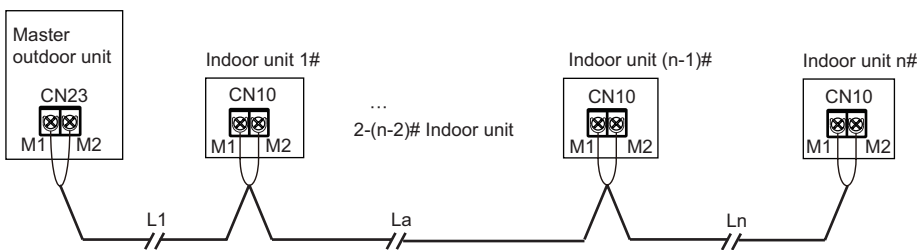

$$L1+La+Ln \leq 2000m$$

For other connection methods (tree topology, star topology, ring topology), please refer to the technical manual or consult technical personnel.

B P/Q communication

Single unit: Use a shielded cable for the P/Q communication and properly earth the shield layer. P and Q ports are located at terminal block “CN6” of the main control board. There is no distinction between negative and positive electrodes. Connect the shield layer to the sheet metal of the electric control box, as shown in the following figure:

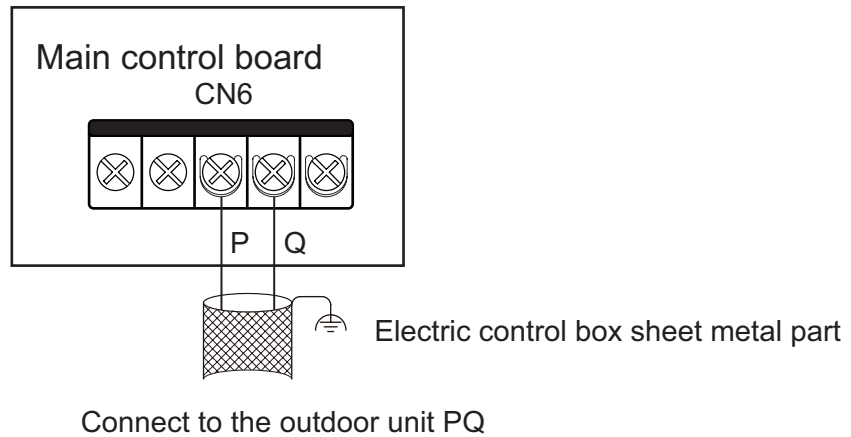

System: The maximum total length of the P/Q communication cable of the Indoor unit and outdoor unit can be up to 1200m, and can be connected in serial, as shown in the figure below:

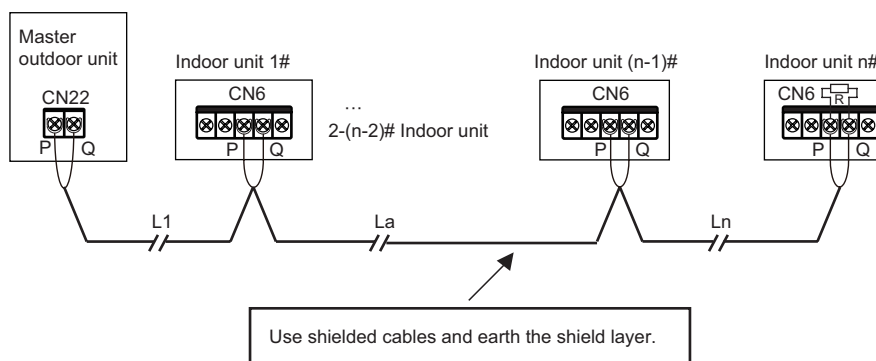

$$L1+La+Ln \leq 1200m$$

C P/Q/E communication

If some of the indoor units in the same refrigerant system are non-V8 series, it is required to connect “P”, “Q”, and “E” for P/Q/E communication.

Single unit: Use a shielded cable for the P/Q/E communication and properly earth the shield layer. P, Q, and E ports are located at terminal block “CN6” of the main control board. There is no distinction between negative and positive electrodes. Connect the shield layer to the sheet metal of the electric control box, as shown in the following figure:

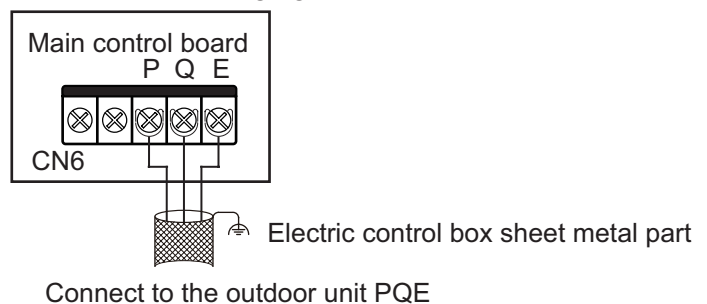

System: The maximum total length of the P/Q/E communication cable of the indoor unit and outdoor unit can be up to 1200m, and can be connected in serial, as shown in the figure below:

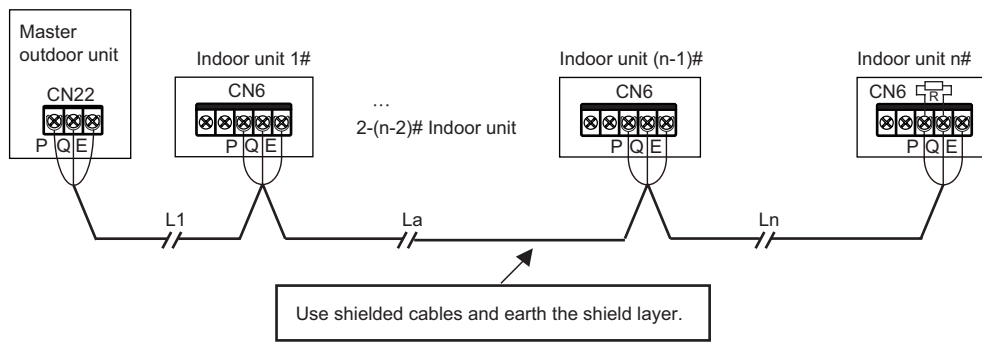

$$L1+La+Ln \leq 1200m$$

⚠ Caution

Either P/Q, P/Q/E communication or HyperLink (M1M2) communication can be selected.

Use only shielded cables for P/Q or P/Q/E communication. Otherwise, the indoor unit and outdoor unit communication may be affected.

A matching resistor needs to be added to the last indoor unit on the PQ (in the accessory bag of the outdoor unit).

④ X1/X2 communication cable connection

The X1X2 communication wiring is mainly connected to the wired controller. The total length of the X1X2 communication wiring can reach 200 meters. Please use shielded wires, but the shield layer cannot be earthed. X1 and X2 ports are located at terminal block "CN6" of the main control board. There is no distinction between negative and positive electrodes. For details, see the following figure:

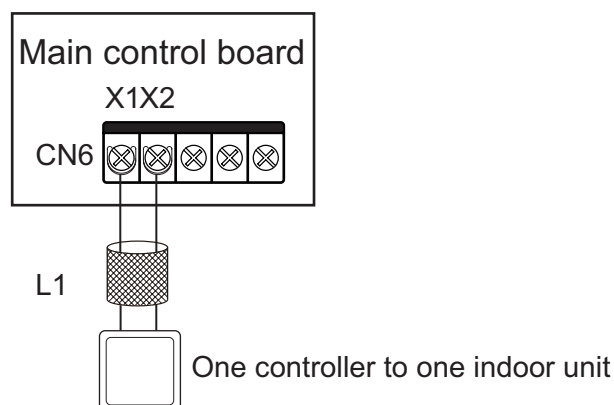

$$L1 \leq 200m.$$

⑤ D1D2 communication wiring connection (limited to outdoor unit and system configuration)

A Achieving one-to-multiple functions of the indoor unit wired controller through D1D2 communication (a maximum of 16 sets)

D1D2 communication is 485 communication. The one-to-more functions of the indoor unit wired controller can be achieved through D1D2 communication, as shown in the figure below:

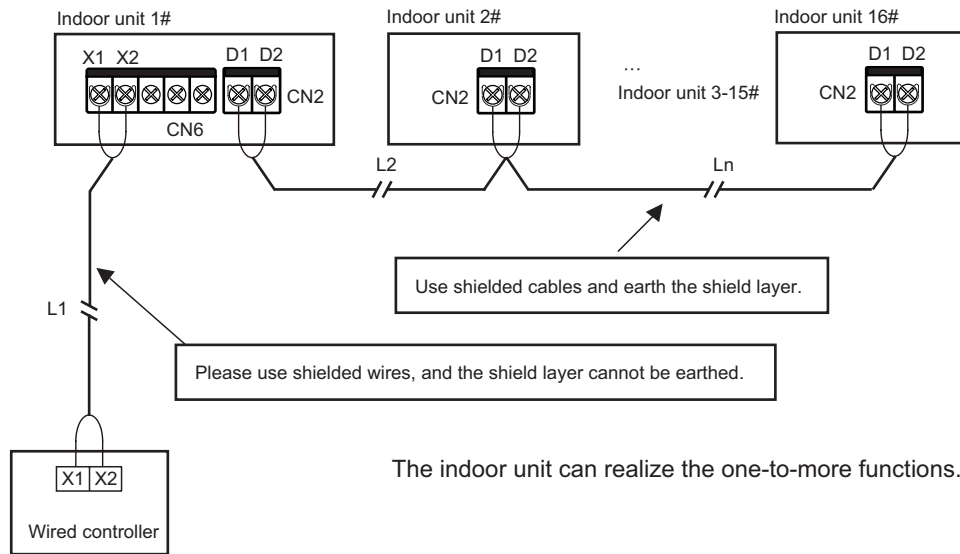

The indoor unit can realize the one-to-more functions.

$$L1 \leq 200\text{m}, L2 + L_n \leq 1200\text{m}$$

Caution

When the indoor units in the same refrigerant system are V8 indoor units, D1D2 communication can enable one-to-multiple functions of the indoor unit wired controller.

B Achieving centralized control of the indoor unit through D1D2 communication

The D1D2 communication wiring can also be connected to the centralized controller to achieve centralized control of the indoor unit, as shown in the figure below:

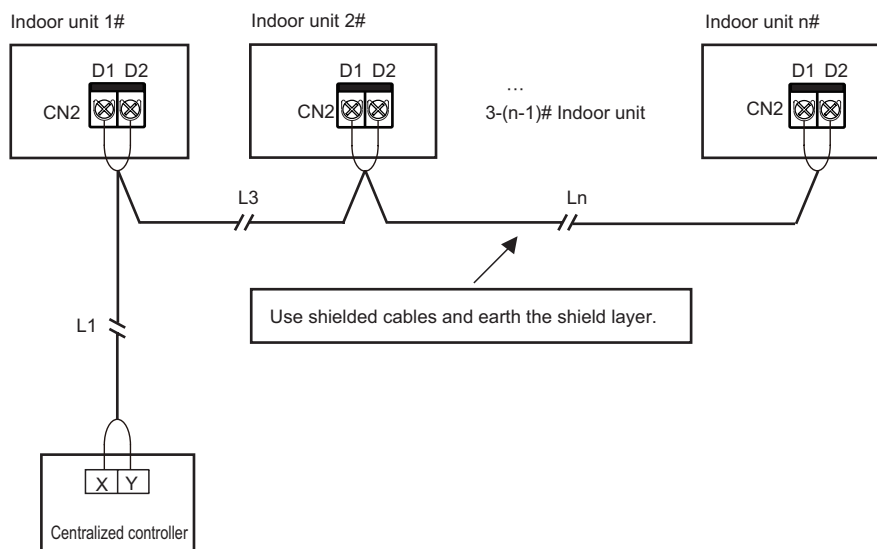

$$L1 + L3 + L_n \leq 1200\text{m}$$

5 External board connection (limited to outdoor unit and system configuration)

The external board is a connection module outside the main control board, including Switch module, 1# Expansion board and 2# Expansion board.

① Switch module connection

Expansion boards can communicate with the main control board through the Switch board. Use one or both of the two expansion boards. The wiring figures are as follows:

Use 1# Expansion board

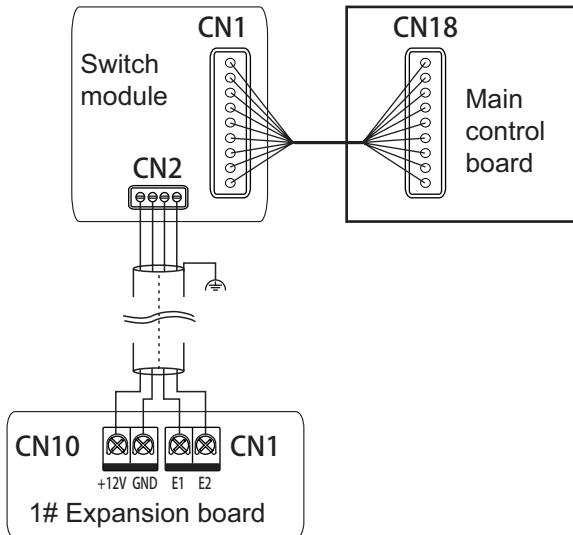

Use 2# Expansion board

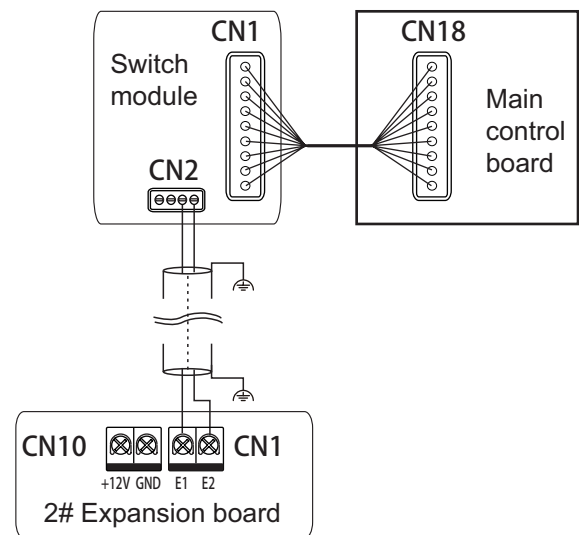

Use 1# and 2# Expansion boards

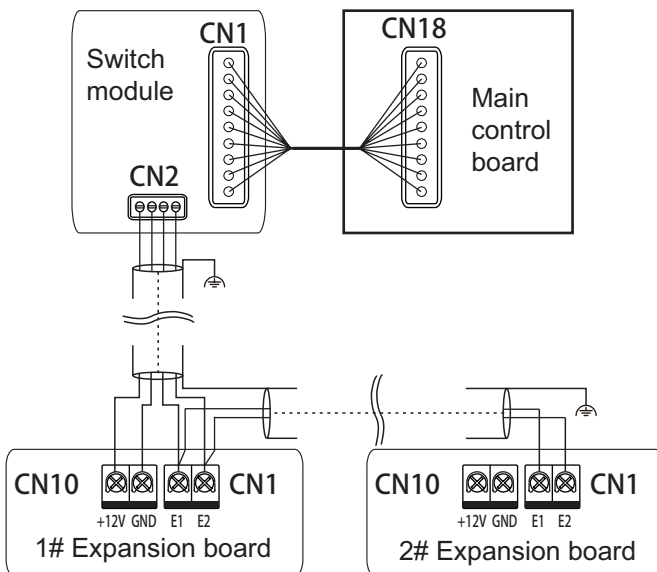

⚠ Caution

For the function introduction of the Switch module, 1# Expansion boards and 2# Expansion boards, please refer to the function module manual.

6 Reclose the electric control box cover

Straighten out the connecting wires and lay them flat, and close the electric control box cover again.

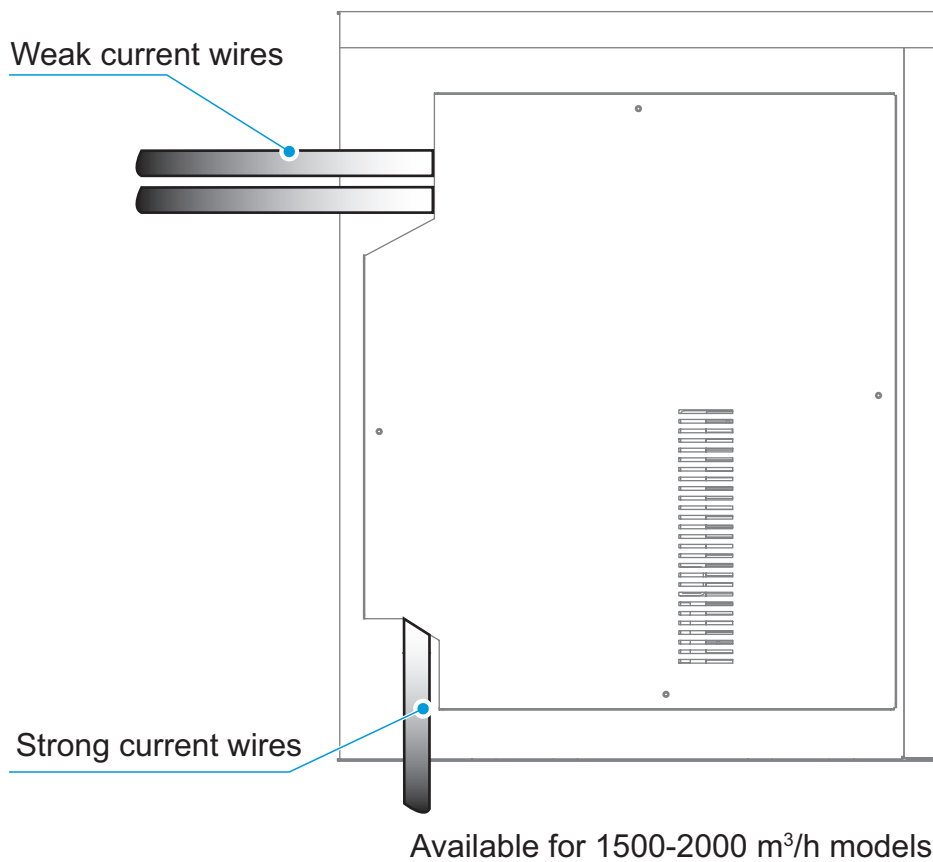
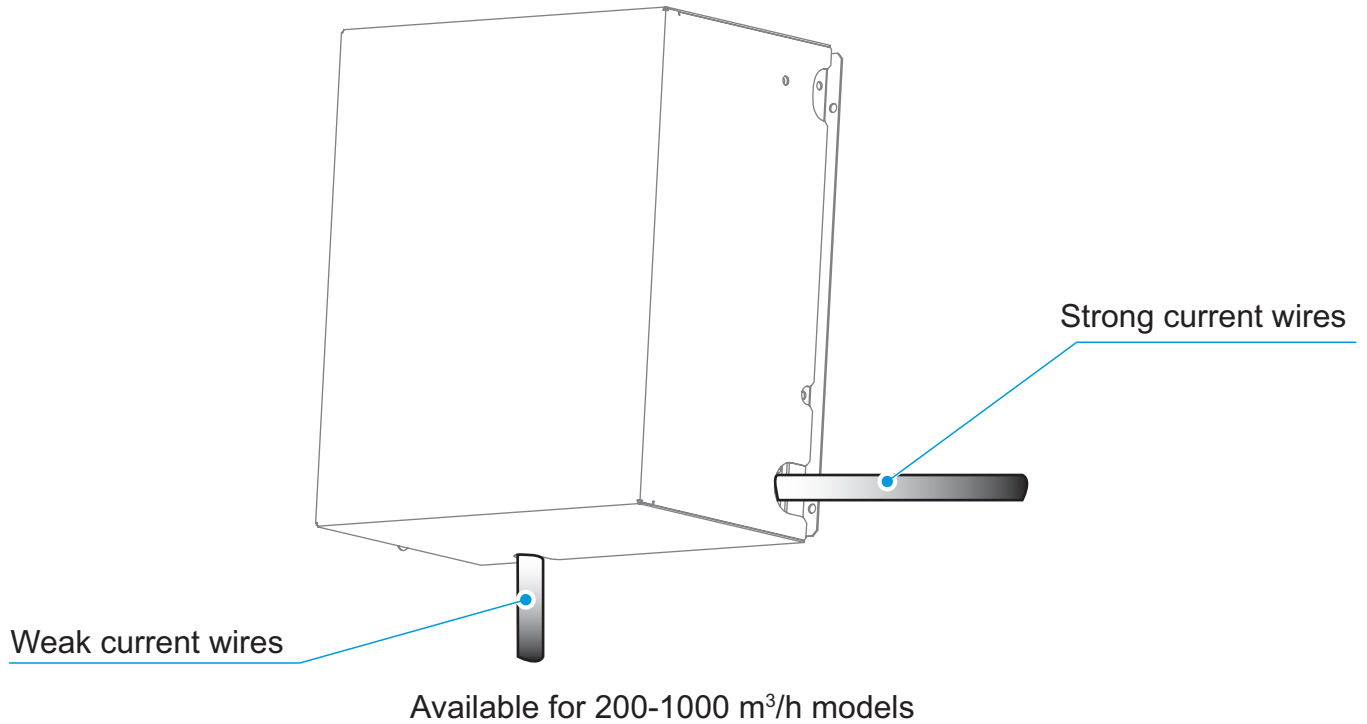

Caution

Do not cover the electric control box during power-on.

When covering the electric control box, arrange the cables carefully and do not clip the connecting wires on the electric control box cover.

5 Error Codes

Error Codes And Definitions

In the following circumstances (warning failures excluded), please stop the HRV immediately, cut off the power switch and contact the local HRV customer service center. The error code is displayed on the display box and the wired controller display.

Error	Error code	Digital display
Emergency stop	A01	001
Outdoor unit fault	A51	A51
Duplicate indoor unit address code	C11	001
Abnormal communication between the indoor unit and outdoor unit	C21	021
Abnormal communication between the indoor unit main control board and fan drive board	C41	041
Abnormal communication between the indoor unit and wired controller	C51	051
Abnormal communication between the indoor unit main control board and 1# Expansion board	C77	077
Abnormal communication between the indoor unit main control board and Switch board	C79	079
Sensor control board fault	dE1	0E1
PM2.5 sensor fault	dE2	0E2
CO2 sensor fault	dE0	0E0
Formaldehyde sensor fault	dE3	0E3
T0 (fresh inlet air temperature sensor) short-circuits or cuts off	E21	021
The indoor temperature sensor short-circuits or cuts off	E24	024
TA (outlet air temperature sensor) short-circuits or cuts off	E81	081
Return air humidity sensor fault	EA2	0A2
Main control board EEPROM fault	P71	071
Air volume code not set	U12	012
Address code not detected	U38	038
IPM (fan module) overcurrent protection	J1E	11E
Instantaneous overcurrent protection for phase current	J11	011

Error	Error code	Digital display
Fan module Over-temperature protection	J2E	
Low bus voltage fault	J3E	
High bus voltage fault	J31	
Phase current sample bias error	J43	
Motor and indoor unit are unmatched	J45	
IPM and indoor unit are unmatched	J47	
Motor startup failure	J5E	
Motor blocking protection	J52	
Speed control mode setting error	J55	
Phase lack protection of motor	J6E	

Operating Status Codes And Definitions (Non-error)

Definition	Code	Digital display
Remote shutdown	d61	
Main control program upgrading	OTA	

Caution

Error codes are displayed only for certain outdoor unit models and indoor unit configurations (including the wired controller and display box).

When the main control program is being upgraded, make sure that the indoor unit and outdoor unit remain powered on. Otherwise, the upgrading process will stop.

Spot Check Description

Use the bi-directional communication wired controller (for example, WDC3-86S) to activate the spot check function in the following steps:

- ① On the main page, hold "☰" and "▲" for 2s to enter the query page. The wired controller displays "CC". Press "▲" or "▼" key to select the indoor unit address n00-n63 (indicating the address of a specific indoor unit), and press the "↵" key to enter the parameter query page.
- ② Press the "▲" or "▼" key to query the parameters, and the parameters can be queried cyclically. See the spot check list below for details.
- ③ Press the "⌚" key to exit the query function.
- ④ On the top of the query page, the "Timing area" displays the spot check serial number, and the "Temperature area" displays the content of the spot check parameters.

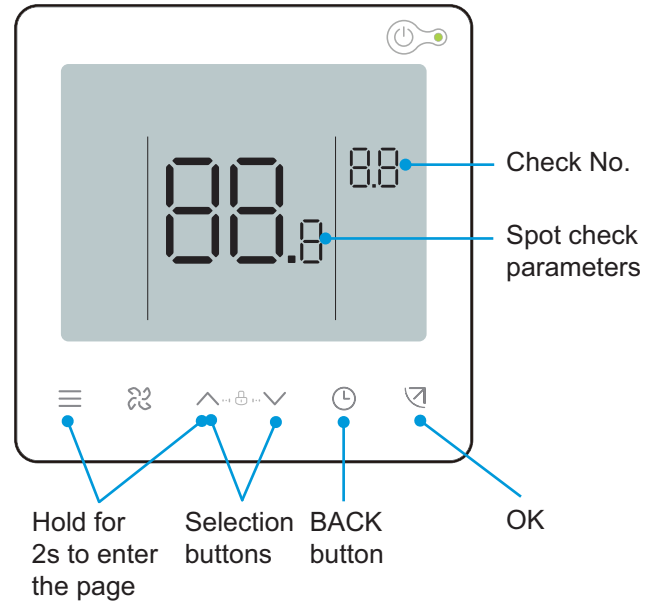

No.	Displayed content
1	Indoor unit and outdoor unit communication address (current indoor unit addresses are displayed every 0.5s)
2	Air volume
3	T1 indoor temperature
4	T4 outdoor temperature
5	TA outlet air temperature [---]
6	RH indoor humidity
7	Run mode
8	Software version No.
9	Fan drive version No.
10	Historical error code
11	[---] is displayed

6 Test Run

Before The Test Run, Make Sure That

- HRV is properly installed.
- The wiring is correct and firm without virtual connection issues. Earth wires have been properly connected.
- The voltage of the power supply is the same as the rated voltage of the HRV.

HRV

- The wired/remote controller switch is operating normally.
- The display of the wired/remote controller is normal, the function keys work normally, the room temperature adjustment is normal, and the air flow and direction adjustment are normal.
- The LED indicator is on.
- Check the HRV one by one for normal operation.

Note

Refer to the “Symptoms That Are Not Faults” in the “Operation” in this manual.

Check List

To ensure a comfortable indoor environment, please run down through the list to check whether the installation of the HRV meets the requirements. Insert a “x” for Fail and a “√” for Pass.

Check Item	Check Criteria	Check Result (Pass/Fail)
Are the indoor units and outdoor units securely installed?	The HRV does not fall or vibrate, and there is no noise.	
Has the installation of the indoor unit been completed?	The unit works properly and no parts are burned out.	
Has a leak test been performed?	The cold/hot air is sufficient.	
Is the heat insulation in good condition (refrigerant piping, drain pipe, and air ducts)?	There is no condensation dripping.	
Were the connecting pipes sealed before installation to prevent dust from entering?	The compressor is functional.	
Is the refrigerant piping filled with nitrogen for shielded welding during the welding process (a nitrogen cylinder is on site)?	There is no oxide film on the inner surface of the connecting pipe. The system is functional with no major failures.	
Has a water drainage test been performed? Is drainage smooth? Is the connection secure?	There is no water leakage.	
Is the power supply voltage consistent with the specified voltage on the unit nameplate?	The unit works properly and no parts are burned out.	
Are the wires and pipes connected correctly?	The unit works properly and no parts are burned out.	
Is the HRV safely earthed?	There is no electric leakage.	
Have wires of the specified size been used?	The unit works properly and no parts are burned out.	
Are the terminal screws securely fastened?	There is no electric shock or fire.	
Are the inlets and outlets of the indoor units and outdoor units free of obstruction?	The cold/hot air is sufficient.	
Has the unit's external static pressure been set for the indoor unit in constant speed mode?	The cooling and heating functions are normal.	
Has the refrigerant piping length and refrigerant charge been recorded?	The amount of refrigerant in the air conditioning system is clear.	
Was an access hole reserved at the installation position of the indoor unit?	The maintenance can be easily carried out.	
Are air filters and grilles installed (at air inlets and outlets)?	The unit works properly.	
Does the temperature of each room meet the requirements during testing?	Users' comfort needs can be satisfied.	
Have you explained to the user how to operate the unit according to the user manual?	The unit is effective.	
Have you explained to the user how to operate and clean the air filter, grille (air inlets and outlets), etc.?	The unit is effective.	

Maintenance and Service

1 Safety Warning

Warning

- For safety reasons, always turn off the HRV and turn off the power before cleaning the HRV.
- Do not disassemble or repair the HRV by yourself; otherwise, it may cause fire or other hazards.
- Only professional service personnel can carry out the maintenance.
- Do not use flammable or explosive materials (such as hair styling agents or pesticides) near the product.
- Do not use organic solvents such as paint thinner to clean this product; otherwise, it may cause cracks, electric shock or fire.
- Only qualified dealers and professionally qualified electricians can install the optional accessories.
- Be sure to use the optional accessories specified by local dealer.
- Improper installation by yourself may result in water leakage, electric shock or fire.
- Do not wash the HRV with water; otherwise, it may cause an electric shock.
- Use a stable standing platform.

2 Cleaning

Cleaning Air Outlets

- ① Wipe the air outlet and panel with a dry cloth.
- ② If a stain is hard to remove, clean it with clean water or neutral detergent.

Caution

- Do not use gasoline, benzene, volatile agents, decontamination powder or liquid insecticides. Otherwise, the air outlet or panel may become discolored or deformed.
- Do not expose the inside of the indoor unit to moisture, as it may result in electric shock or fire.
- When cleaning the louver with water, do not scrub it violently.
- If the HRV is used without an air filter, the accumulation of dust in the HRV will often cause malfunctions due to the failure to remove dust from the indoor air.

Maintenance

During in-depth maintenance, the HRV should be cleaned and maintained by professional technicians every 2 to 3 years.

Complete the following steps before the HRV is put out of use for a long period:

- ① If the HRV is not in use for a long time due to seasonal changes, keep the unit running for 4-5 hours in fan mode until the unit becomes completely dry. Otherwise, it may grow mold indoors and have negative health effects.
- ② When not in use for a long time, power off or unplug the power plug to reduce standby power consumption, and wipe the wireless remote controller with a clean soft dry cloth and remove the battery.
- ③ Turn on the power switch 12 hours before using the HRV again. In addition, in seasons when HRV are frequently used, keep the power switch on. Otherwise, failures may occur.

Caution

Before the HRV is idle for a long time, the internal components of the outdoor units should be checked and cleaned regularly. For more details, please contact the local HRV customer service center or special technical service department.

Check the return air inlet and outlet of the outdoor unit and indoor unit after long periods of use to see if they are blocked; if an inlet/outlet is blocked, clean it immediately.

3 Service

During early use, one should check the fan operation regularly.

The cleaning regulation for air filter depend on local environment. It could be clean by vacuum dirt exhauster or water, if heavy dust accumulates, it should use neutral detergent to clean it, and then dry it in shady and cool place for 20 to 30 minutes and replace it.

Clean the core at least 2 years a time by vacuum dirt exhauster to remove dust and foreign substance in the unit assemblies, do not touch the assemblies by exhauster and flush by water to avoid core damage.

Check the fan every half a year to maintain the well balance of it and check whether the axletree has loosed.

Attached Page

ErP Information

Fan Types	Centrifugal forward curved fan		
Directive (or Standard) for Regulation			ErP Directive 2009/125/EC COMMISSION REGULATION (EU) No 327/2011
Model Name	WZDK170-38G-2 +LX-245*203*12-48J 1320	Rev.	
Prepare by			

Specified Information of Fan:

No.	Information Item	Comment
1	$\eta_{\text{target}}=$	32.5%
2	Overall efficiency(η_e)=	33.02%
3	Pass or not (Criteria: $\eta_e \geq \eta_{\text{target}}$)	Pass
4	Measurement category (A -D)	A
5	Efficiency category (static or total)	Static
6	Efficiency grade at optimum energy efficiency point	N =44.52
7	VSD is integrated within the fan	YES
8	Year of Manufacture	Ref. to the Unit Nameplate
9	Manufacturer's name and place of manufacture	Ref. to the Unit Nameplate
10.1	Rated motor power input(s) (kW), at optimum energy efficiency	0.1517 kw
10.2	Rated motor flow rate(s) at optimum energy efficiency	0.1614m ³ /s
10.3	Rated motor pressure(s) at optimum energy efficiency	270 Pa
11	Rotations per minute (R.P.M)at the optimum energy efficiency point	1320 r/min
12	Specific ratio	1.001
13	Information relevant for facilitating disassembly, recycling or disposal at end-of-life	all materials can be recycled
14	Information relevant to minimize impact on the environment and ensure optimal life expectancy as regards installation, use and maintenance of the fan	For installation, the clearance of 500 mm shall be kept from inlet
15	Description of additional items used when determining the fan energy efficiency,such as ducts, that are not described in the measurement category and supplied with the fan.	Measurement category A, fan is free inlet and outlet conditions
16	Motor manufacturer	NIDEC SHIBAURA(ZHEJIANG)CORP.

ErP Information

Fan Types	Centrifugal forward curved fan		
Directive (or Standard) for Regulation	ErP Directive 2009/125/EC COMMISSION REGULATION (EU) No 327/2011		
Model Name	WZDK750-38G-W-1+LX-261*234*15 -48J 1300	Rev.	
Prepare by			

Specified Information of Fan:

No.	Information Item	Comment
1	$\eta_{\text{target}}=$	34.14%
2	Overall efficiency(η_e)=	49.7%
3	Pass or not (Criteria: $\eta_e \geq \eta_{\text{target}}$)	Pass
4	Measurement category (A -D)	A
5	Efficiency category (static or total)	Static
6	Efficiency grade at optimum energy efficiency point	N = 59.51
7	VSD is integrated within the fan	YES
8	Year of Manufacture	Ref. to the Unit Nameplate
9	Manufacturer's name and place of manufacture	Ref. to the Unit Nameplate
10.1	Rated motor power input(s) (kW), at optimum energy efficiency	0.276 kw
10.2	Rated motor flow rate(s) at optimum energy efficiency	0.34m ³ /s
10.3	Rated motor pressure(s) at optimum energy efficiency	360 Pa
11	Rotations per minute (R.P.M)at the optimum energy efficiency point	1300 r/min
12	Specific ratio	1.001
13	Information relevant for facilitating disassembly, recycling or disposal at end -of-life	All materials can be recycled
14	Information relevant to minimize impact on the environment and ensure optimal life expectancy as regards installation, use and maintenance of the fan	For installation,the clearance of 500 mm shall be kept from inlet
15	Description of additional items used when determining the fan energy efficiency,such as ducts, that are not described in the measurement category and supplied with the fan.	Measurement category A, fan is free inlet and outlet conditions
16	Motor manufacturer	Panasonic Appliances Motor (Hangzhou) Co.Ltd.

Required information for RVU in COMMISSION REGULATION (EU) No.1254/2014 ANNEX IV

No.	Information Item	Comment
1	Supplier's name	Frigicoll
2	Model name	HRV-D200(C)
3	SEC(kWh/(m ² .a))	Cold region:-79.3
		Average region:-41.5
4	Declared typology	RVU,BVU
5	Type of drive	Multi-speed
6	Type of HRS	Recuperative
7	Thermal efficiency(%)	81
8	Maximum flow rate(m ³ /h)	200
9	Electric power input(kW)	71
10	Casing sound power level(dB)	45
11	Reference flow rate(m ³ /h)	0.045
12	Reference pressure difference(Pa)	52
13	SPI(W/(m ³ /h))	0.23
14	Control factor and typology	Local demand control
15	Maximum leakage rate(%)	10 Or less
16	Mixing rate of non-ducted	-
17	Visual filter warning	Refer to instruction book
18	Instructions to install regulated supply/exhaust grilles for unidirectional ventilation	-
20	Airflow sensitivity for non-ducted units	-
21	Air tightness for non-ducted units	-
22	AEC(kWh/a)	Average region 1.7
23	AHS(kWh primary energy/a)	Average 45.2,Cold 88.4,Warm 20.4

Required information for NRVU in COMMISSION REGULATION (EU) No.1253/2014 ANNEX V

No.	Information Item	Comment				
1	Supplier's name	Frigicoll				
2	Model name	500	800	1000	1500	2000
3	Declared typology	NRVU,BVU	NRVU,BVU	NRVU,BVU	NRVU,BVU	NRVU,BVU
4	Type of drive	Multi-speed	Multi-speed	Multi-speed	Multi-speed	Multi-speed
5	Type of HRS	Other	Other	Other	Other	Other
6	Thermal efficiency(%)	80.6	78.7	82.8	75.5	77.2
7	Nominal flow rate(m ³ /s)	0.139	0.222	0.278	0.417	0.556
8	Electric power input(kW)	0.157	0.324	0.383	0.677	0.956
9	SFPint(W/(m ³ /h))	682	792	785	702	730
10	Face velocity(m/s)	0.66	0.87	0.87	1.0	1.0
11	Nominal external pressure(Pa)	96	146	160	180	200
12	Internal pressure drop(Pa)	189	357	384	253	322
13	Internal pressure drop of non-ventilation components(Pa)	-	-	-	-	-
14	Efficiency in Regulation (EU) NO 327/2011	Out of scope	33	33	49.7	49.7
15	Maximum leakage rate(%)	10 Or less	10 Or less	10 Or less	10 Or less	10 Or less
16	Energy classification of the filters	-	-	-	-	-
17	Visual filter warning	Refer to instruction book				
18	Casingsound power level(dB)	50	55	54	69	70

frigicoll

OFICINA CENTRAL
Blasco de Garay, 4-6
08960 Sant Just Desvern
Barcelona
Tel. 93 480 33 22
<http://www.frigicoll.es>

BUREAU CENTRAL
Parc Silic-Immeuble Panama
45 rue de Villeneu
94150 Rungis
Tél. +33 9 80 80 15 14
<http://www.frigicoll.es>