

Cassette 600x600 Multisystem

PRODUCT SHEET



KID-02 S
Standard controller

Product certified by: 



FEATURES

Model	KCI-26 DMR11	KCI-35 DR12	KCI-52 DR12
Cooling capacity	2,64 kW	3,51 kW	5,27 kW
Heating capacity	2,93 kW	4,39 kW	5,42 kW
Airflow	450/500/580 m ³ /h	416/504/617 m ³ /h	540/625/720 m ³ /h
Sound pressure	29 dB(A)	33 dB(A)	33,50 dB(A)
Power supply	220-240 V / 1 / 50 Hz		
Communication wiring	(3+T)x2,50 mm ²		
Refrigerating pipes	Ø1/4" / Ø3/8"	Ø1/4" / Ø3/8"	Ø1/4" / Ø1/2"

WIRING DIAGRAM

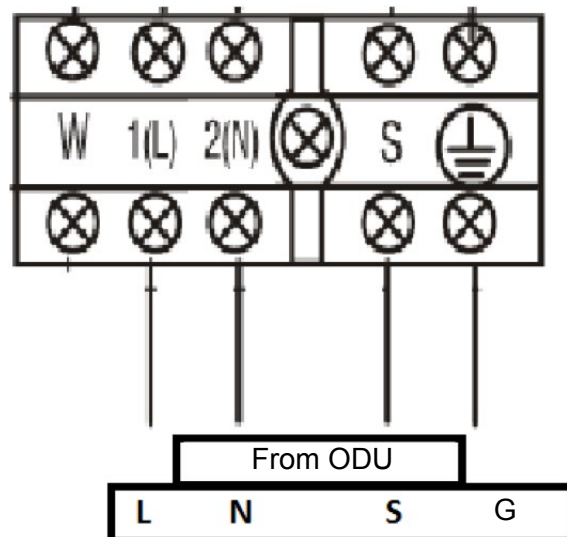

NOTES:
 (1) The data and specifications present in this sheet may vary without notice.
 (2) The images on this sheet are indicative and may be different from the final machine.

DIMENSIONS & WEIGHT OF INDOOR UNIT

Model	Weight	A	B	C	D	E	F
KCI-26 DMR11	17,20 kg	570 mm	570 mm	260 mm	647 mm	647 mm	50 mm
KCI-35 DR12	18,50 kg	570 mm	570 mm	260 mm	647 mm	647 mm	50 mm
KCI-52 DR12	18,60 kg	570 mm	570 mm	260 mm	647 mm	647 mm	50 mm

